



Photometric Test Report



EclProfile FWHPVW

450W high quality VariableWhite LED
ellipsoidal, compatible with PRL and PRLZ lenses

(ECLPRL26BK)

CONTENTS

Table of contents	2
Testing process	3
PRL 26° Lens:	
Full On	4
Warm White	9
Cold White	14
2800K	19
3200K	24
4000K	29
5600K	34
6000K	39

TESTING PROCESS

Prolights has its own optical testing laboratory in order to provide accurate photometric reports for its lighting products. The testing laboratory contains certain variety of precise lighting measurement systems that ensure an optimal reading of all the characteristic parameters of the lighting devices. All measurements are made at a controlled room temperature of 20°C without any external light sources. This photometric report is obtained through the data measured by a high precision measurement system and analyzed by a dedicate software.

Prolights measurement instrument

Prolights measurement instrument is a complete measurement system for any light source. It's equipped with two-axis goniometer, that enables to measure the full 3D distribution field of the light source. This instrument measures the light intensity, the beam angle and the most significative colors parameters, like color temperature, spectral distribution, CRI, CQS, TM-30 with a very high accuracy rate.

Please Note: All measurements are made with light source at operating temperature. Before starting the measurement, the instrument analyzes the process of the light source during the heating phase. The measuring process of all the parameters begins only when the light emission is stable, that is with a variation of less than 0.5% in a 15 minutes time frame.

Prolights measurement software

The software provides user friendly interface for the operator who does the measurements, and it also analyzes and processes all the collected data by the instrument. With this software it is possible to see the measured data in real-time and it is possible to examine all the measured data and graphics afterwards as well. All information is collected in a specific Prolights template, and the software creates also IES and LDT files, which are widely used to transfer the photometric data, and to develop lighting system.

Additionally, the fixtures are rechecked using various hand-held instruments like Sekonic C-700 and Gossen Mavospec Base, this is done to ensure, that the data in the photometric report are as accurate as possible.



Total lumen output:

16002 lm

Peak candela output:

107435 cd

Light quality:

CRI: 97,6

Color temperature:

4174 K

PRODUCT NAME:

ECLFWHPVW

MEASURAMENT CONDITIONS:

Beam angle:

PRL26

Target:

Full On

Operator:

Giuseppe della Peruta

Date and time:

07/01/2026 10:43:33

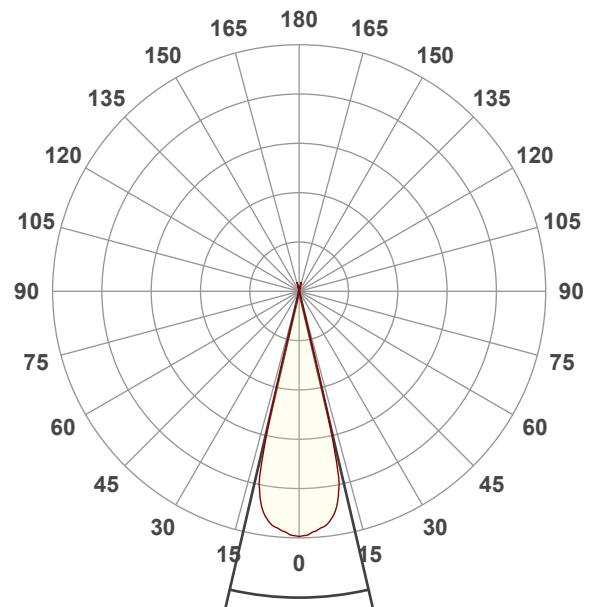

Beam angle 50%: 26,2°

Field angle 10%: 27,8°

Cut off angle 2.5%: 28,1°

Spectra

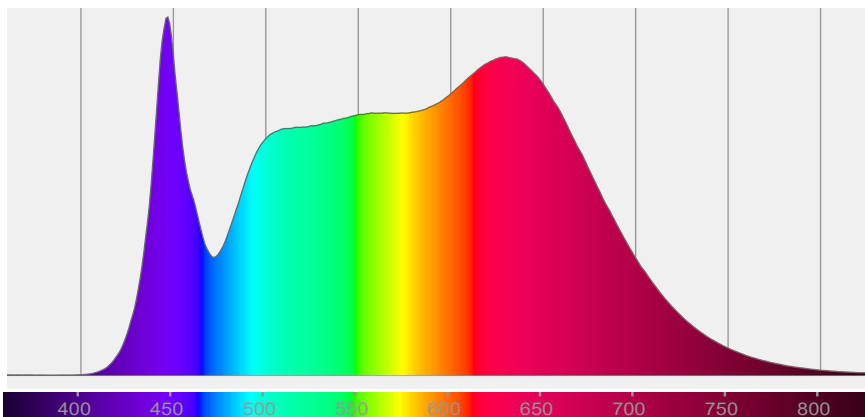

COLOR DETAILS

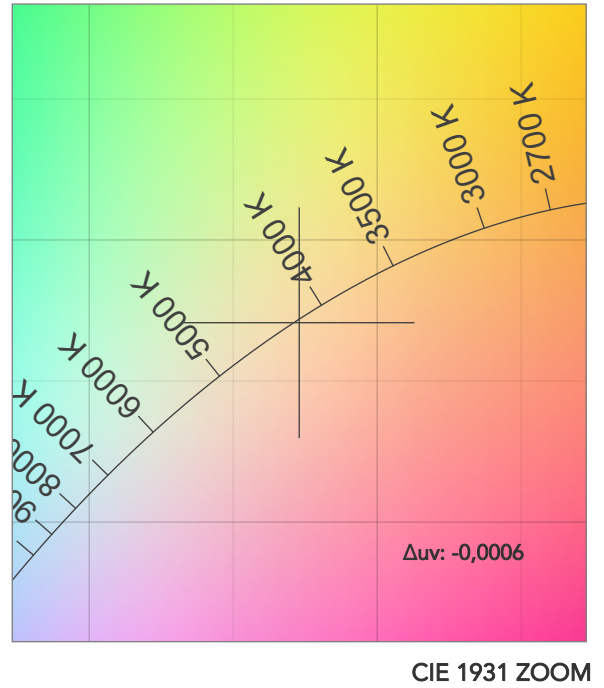
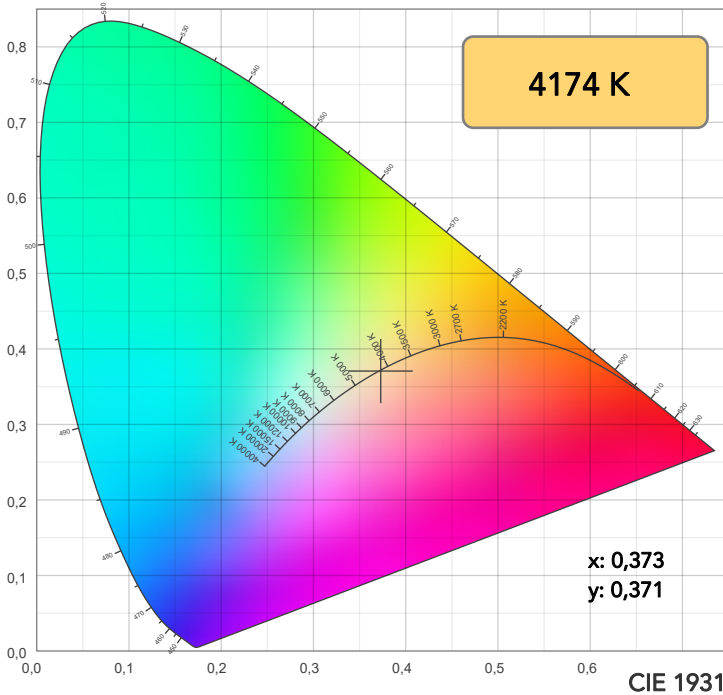

TM30: 96,0

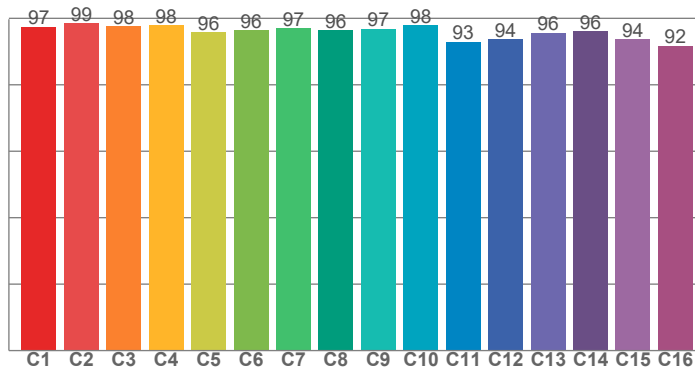

CRI: 97,6 (R1-R8)

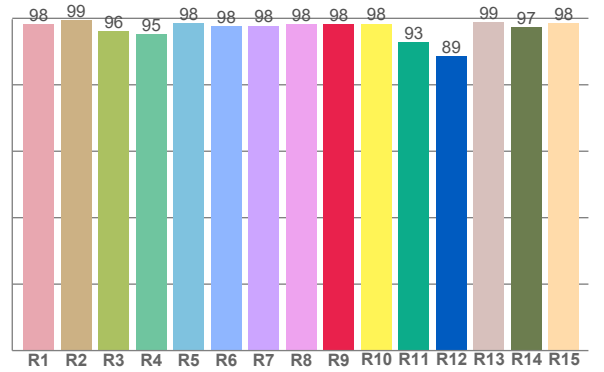

CRI R values, only R1-R8 are used to calculate final CRI value

R1	R2	R3	R4	R5	R6	R7	R8	R9	R10	R11	R12	R13	R14	R15
98,2	99,4	96,1	95,3	98,5	97,6	97,8	98,1	98,3	98,4	92,7	88,6	98,7	97,4	98,4

TM30 C values, 16 binned values out of total of 99 C values

C1	C2	C3	C4	C5	C6	C7	C8	C9	C10	C11	C12	C13	C14	C15	C16
97,4	98,5	97,6	97,9	95,8	96,5	97,0	96,4	96,9	97,9	93,0	93,8	95,7	96,1	93,6	91,8

CQS Q values

Q1	Q2	Q3	Q4	Q5	Q6	Q7	Q8	Q9	Q10	Q11	Q12	Q13	Q14	Q15
99,4	99,5	94,0	97,5	97,7	95,5	98,0	99,3	98,7	98,9	99,6	98,9	98,9	99,3	99,5

CQS: 97,7

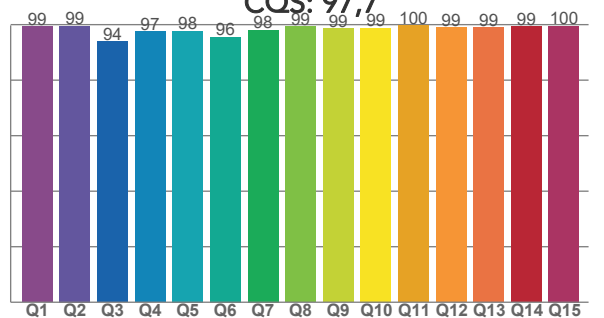

COLOR PARAMETERS

Color temperature	Color rendering index	Red component	Color fidelity	Color gamut	Color quality scale	Television lighting index	Color coordinate cie 1931	Color coordinate cie 1931	Color deviation from black body
CCT	CRI	CRI R9	TM30 Rf	TM30 Rg	CQS	TLCI	x	y	Δuv
4174 K	97,6	98,3	96,0	102,6	97,7	98	0,373	0,371	-0,0006

TM30 DETAILS

Rf 96,0
Fidelity index Rf

Rg 102,6
Gammut index

Hue Bin	R _f	Graphic shifts (%)	
		Chroma	Hue
1	97	0%	-1%
2	99	0%	0%
3	98	0%	1%
4	98	0%	0%
5	96	0%	1%
6	96	2%	1%
7	97	2%	0%
8	96	1%	0%
9	97	1%	1%
10	98	0%	1%
11	93	2%	4%
12	94	3%	2%
13	96	4%	-1%
14	96	2%	1%
15	94	3%	-3%
16	92	3%	-5%

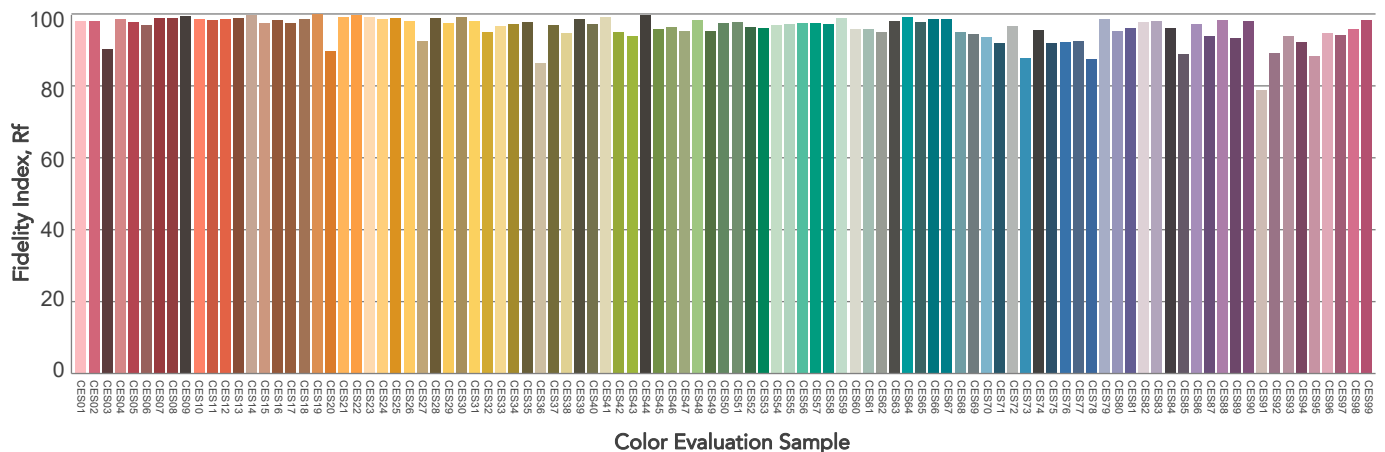
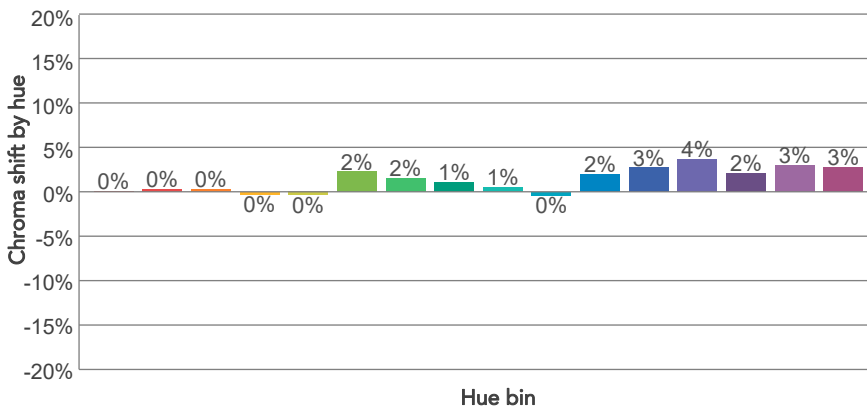
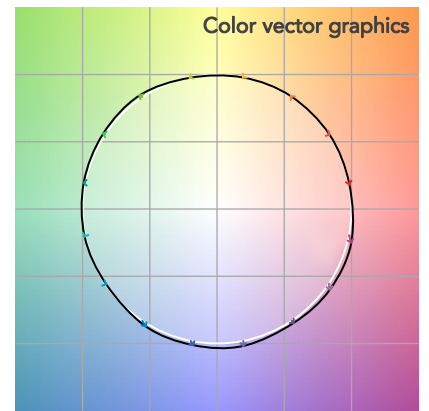
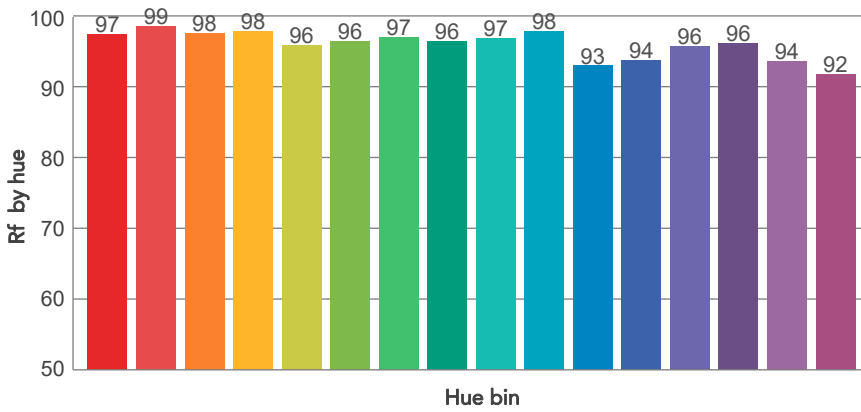
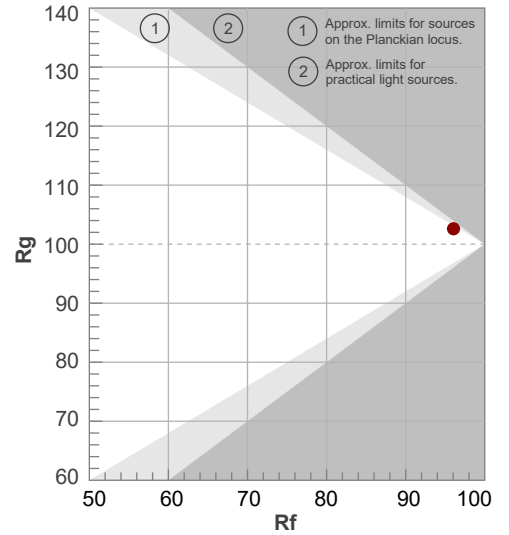

BEAM DETAILS



Beam angle 50%	Field angle 10%	Cut off angle 2,5%	Intensity ratio in 120° cone	Intensity ratio in 90° cone
26,2°	27,8°	28,1°	100,0%	100,0%

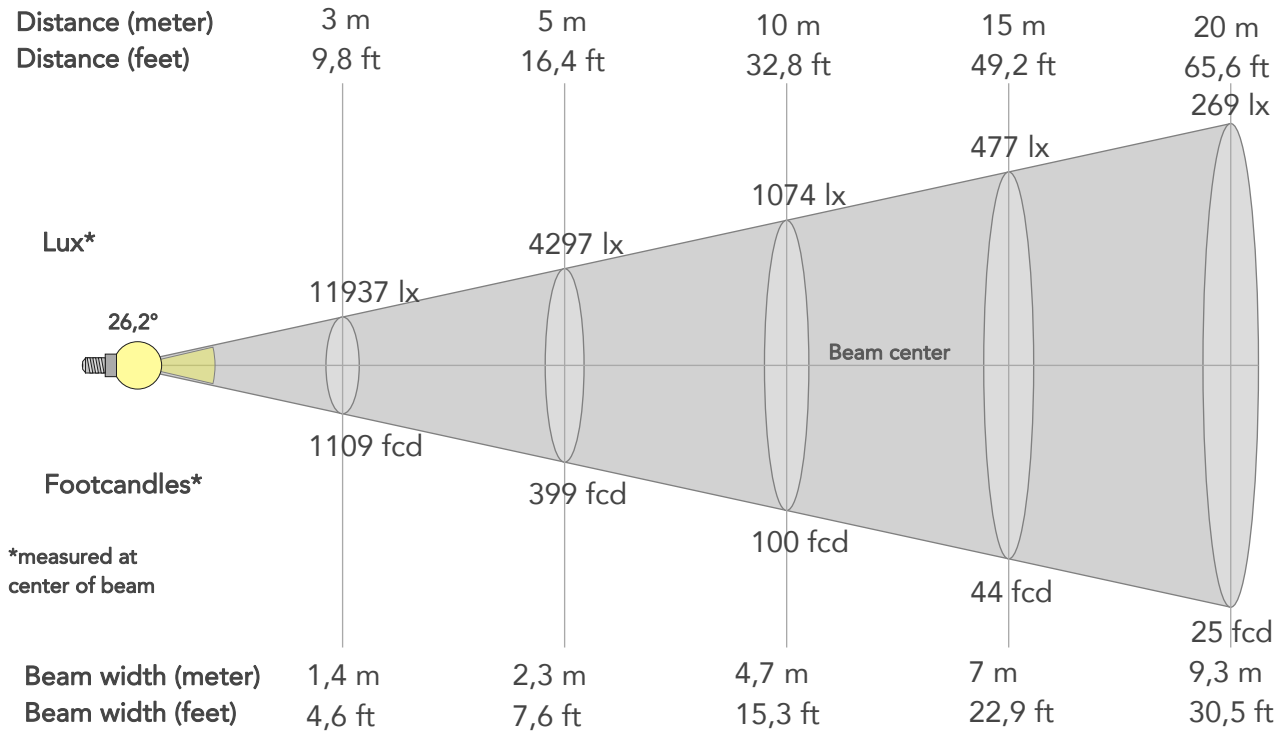

BEAM INTENSITIES AND WIDTHS

Distance	1m	2m	3m	4m	5m	7,5m	10m	15m	20m	25m	30m	40m	50m
Distance	3,3ft	6,6ft	9,8ft	13,1ft	16,4ft	24,6ft	32,8ft	49,2ft	65,6ft	82ft	98,4ft	131,2ft	164ft
Lux	107435lx	26859lx	11937lx	6715lx	4297lx	1910lx	1074lx	477lx	269lx	172lx	119lx	67lx	43lx
Footcand.	9981fcd	2495fcd	1109fcd	624fcd	399fcd	177fcd	100fcd	44fcd	25fcd	16fcd	11fcd	6fcd	4fcd
Beam wid.	0,5m	0,9m	1,4m	1,9m	2,3m	3,5m	4,7m	7m	9,3m	11,6m	14m	18,6m	23,3m
Beam wid.	1,5ft	3,1ft	4,6ft	6,1ft	7,6ft	11,4ft	15,3ft	22,9ft	30,5ft	38,2ft	45,8ft	61,1ft	76,3ft

LINEAR DISTRIBUTION DIAGRAM

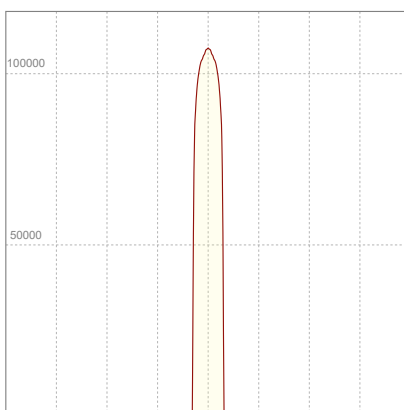

ELECTRICAL SPECIFICATIONS

Input voltage	Input current	Input power	Power FC	Efficiency
225V	2,00A	438,6W	0,97	36lm/W

ISO DIAGRAMS

ISO CANDELA DIAGRAM

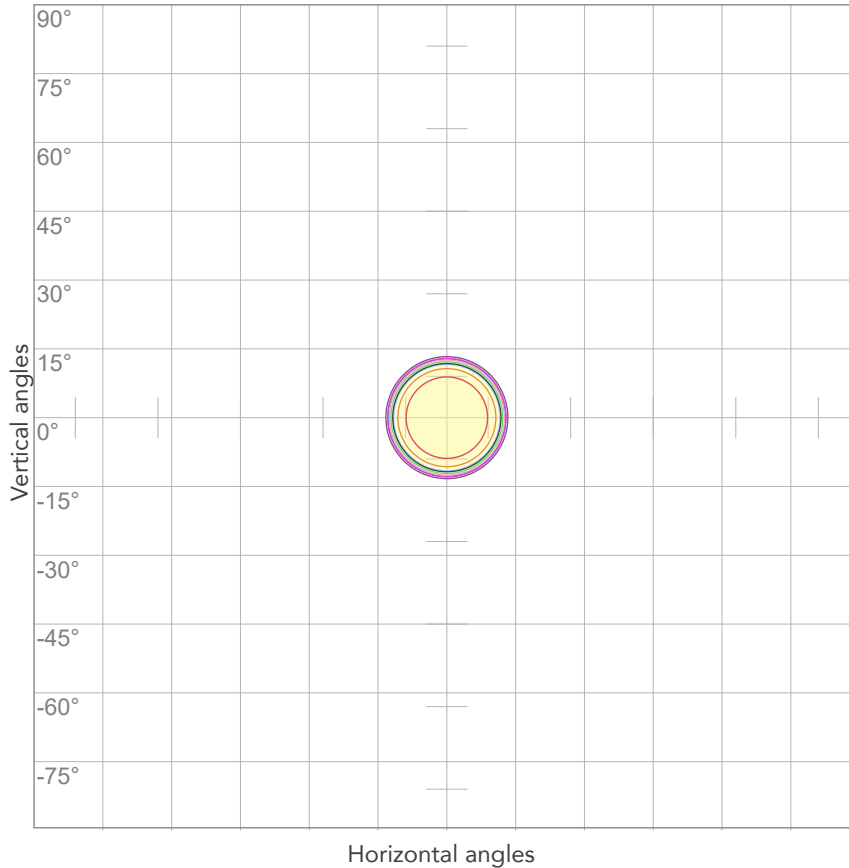

10%	10743 cd
20%	21487 cd
30%	32230 cd
40%	42974 cd
50%	53717 cd
60%	64461 cd
70%	75204 cd
80%	85948 cd

Conditions:

Number of c-planes: 2

Candela at center: 107435 cd

ISO LUX DIAGRAM

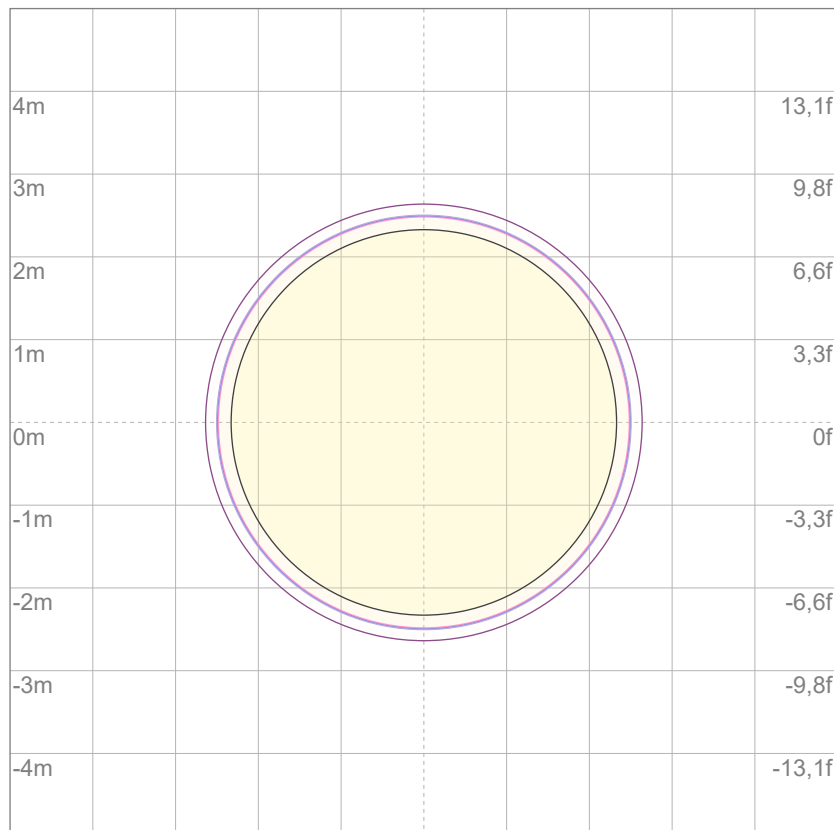

Mounting height: 10 meters (33 feet)

3%	32,2 lx
5%	53,7 lx
10%	107 lx
30%	322 lx
50%	537 lx

Conditions:

Number of c-planes: 2

Lux at center: 1074 lx

Lux distribution on a surface when lamp is mounted at 10 meters from the surface.



Total lumen output:

12190 lm

Peak candela output:

80960 cd

Light quality:

CRI: 96,7

Color temperature:

2618 K

PRODUCT NAME:

ECLFWHPVW

MEASUREMENT CONDITIONS:

Beam angle:

PRL26

Target:

Warm White

Operator:

Giuseppe della Peruta

Date and time:

07/01/2026 11:00:43

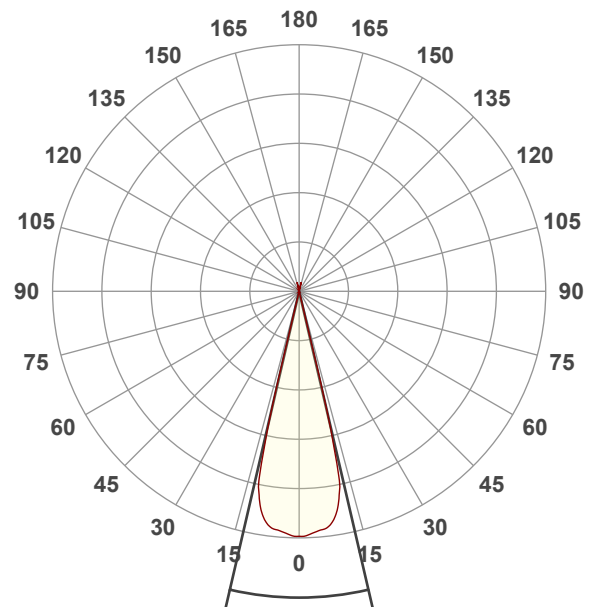

Beam angle 50%: 26,1°

Field angle 10%: 27,8°

Cut off angle 2.5%: 28,1°

Spectra

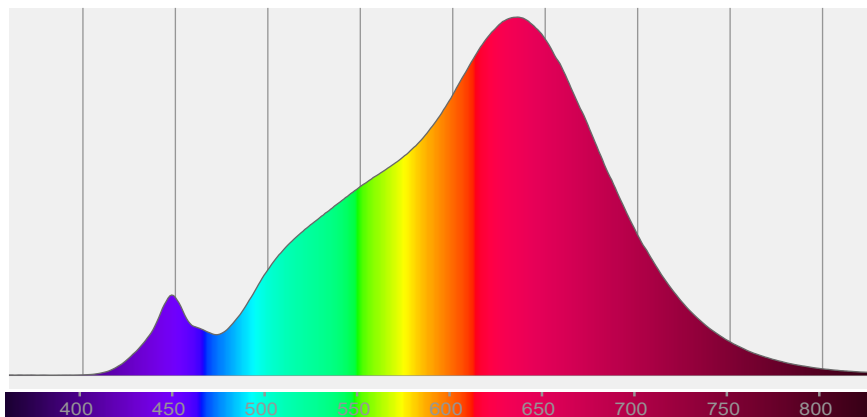

COLOR DETAILS

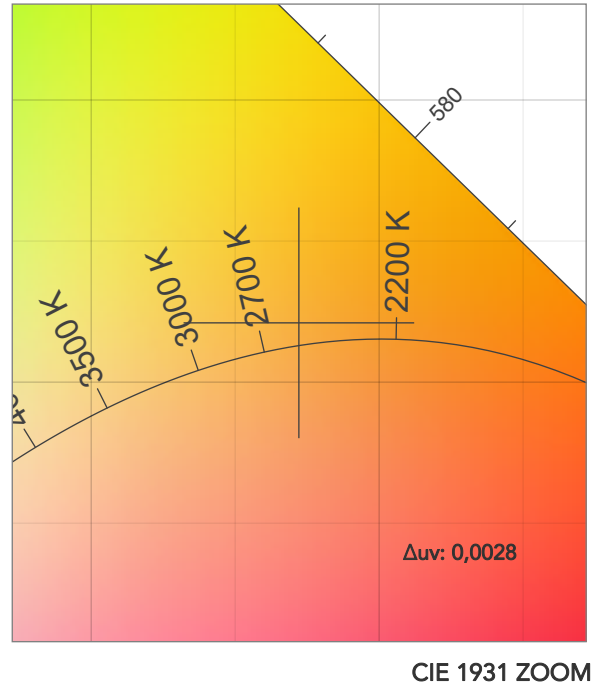
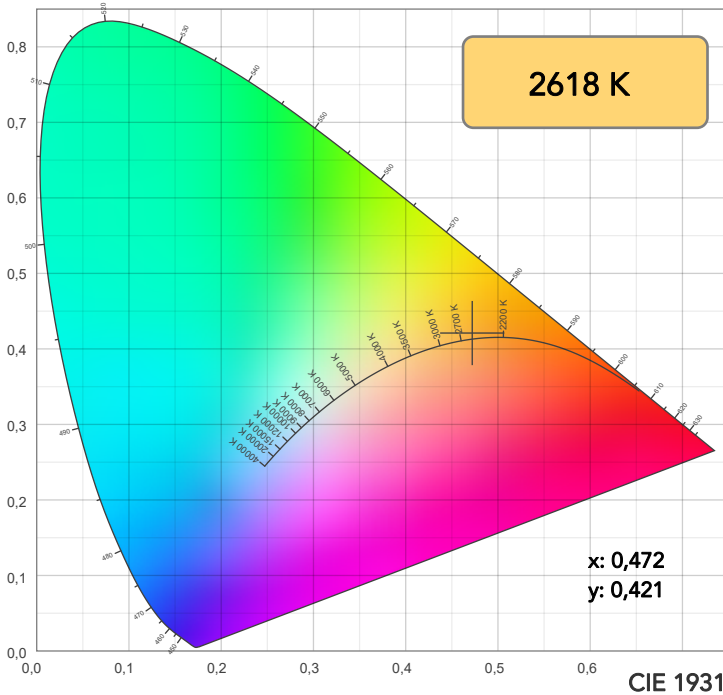

TM30: 96,0

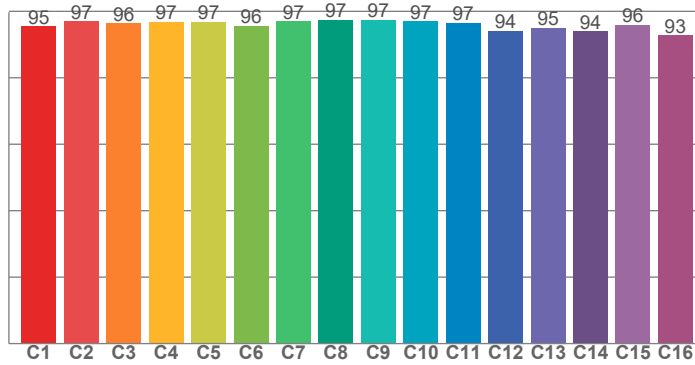

CRI: 96,7 (R1-R8)

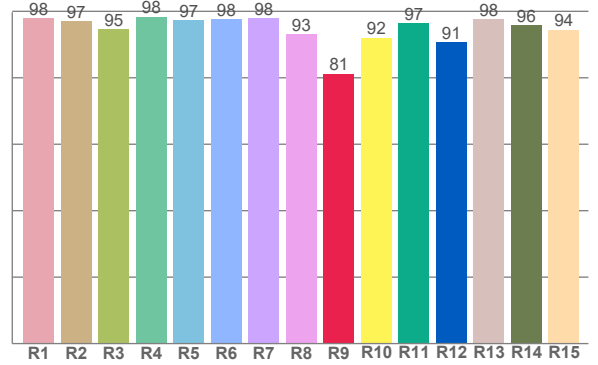

CQS: 92,2

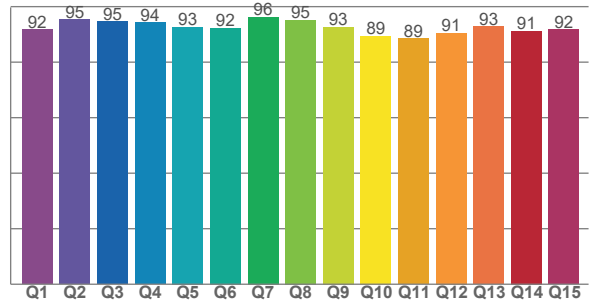

CRI R values, only R1-R8 are used to calculate final CRI value

R1	R2	R3	R4	R5	R6	R7	R8	R9	R10	R11	R12	R13	R14	R15
97,9	97,0	94,5	98,4	97,4	97,6	98,0	93,0	81,2	92,1	96,6	90,7	97,6	95,9	94,5

TM30 C values, 16 binned values out of total of 99 C values

C1	C2	C3	C4	C5	C6	C7	C8	C9	C10	C11	C12	C13	C14	C15	C16
95,4	97,0	96,4	96,8	96,9	95,7	97,1	97,4	97,4	97,1	96,6	94,2	95,0	94,1	95,9	92,9

CQS Q values

Q1	Q2	Q3	Q4	Q5	Q6	Q7	Q8	Q9	Q10	Q11	Q12	Q13	Q14	Q15
91,8	95,4	94,6	94,2	92,7	92,3	96,2	95,2	92,6	89,4	88,5	90,5	92,9	91,1	91,8

COLOR PARAMETERS

Color temperature	Color rendering index	Red component	Color fidelity	Color gamut	Color quality scale	Television lighting index	Color coordinate cie 1931	Color coordinate cie 1931	Color deviation from black body
CCT	CRI	CRI R9	TM30 Rf	TM30 Rg	CQS	TLCI	x	y	Δuv
2618 K	96,7	81,2	96,0	100,0	92,2	96	0,472	0,421	0,0028

TM30 DETAILS

Rf 96,0
Fidelity index Rf

Rg 100,0
Gammut index

Hue Bin	R _f	Graphic shifts (%)	
		Chroma	Hue
1	95	-2%	-1%
2	97	-2%	0%
3	96	-1%	1%
4	97	-1%	1%
5	97	0%	3%
6	96	2%	2%
7	97	1%	-1%
8	97	1%	0%
9	97	0%	-2%
10	97	-1%	0%
11	97	0%	2%
12	94	1%	-1%
13	95	2%	-3%
14	94	2%	-4%
15	96	0%	-2%
16	93	-1%	-5%

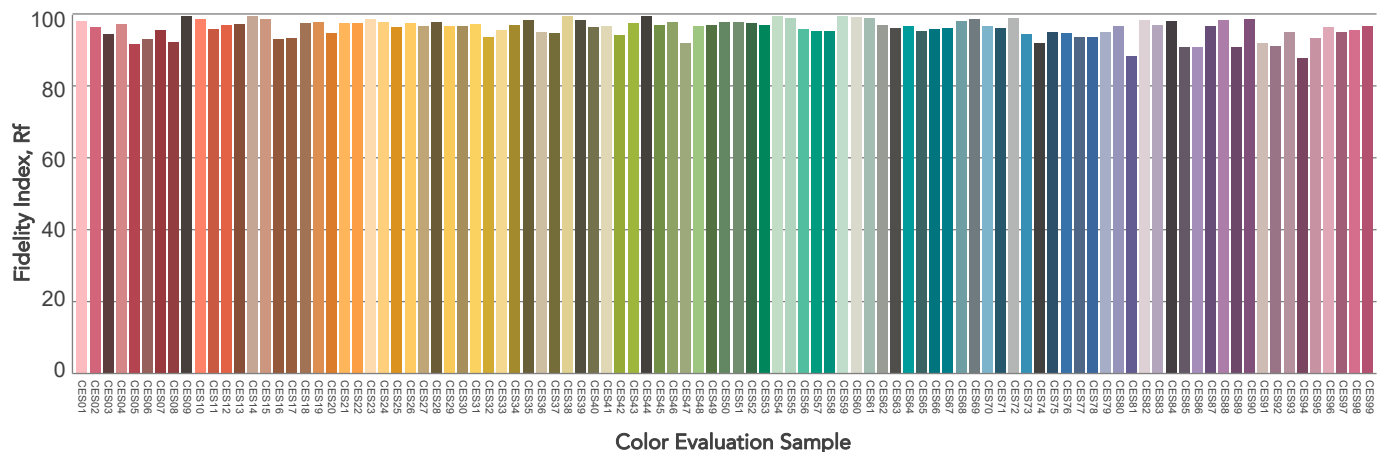
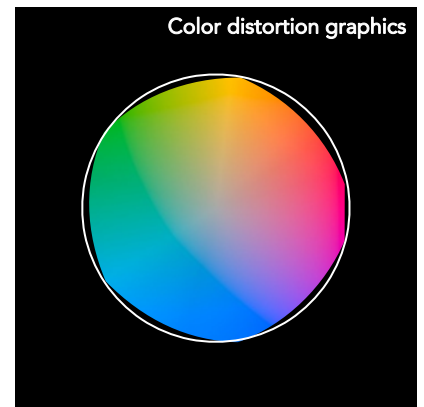
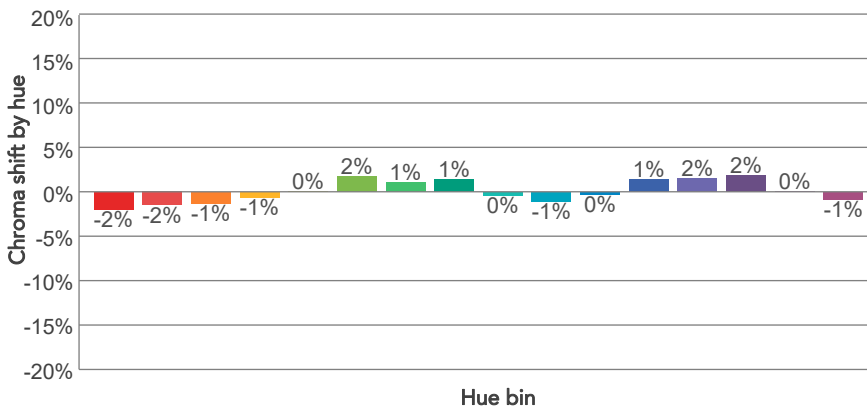
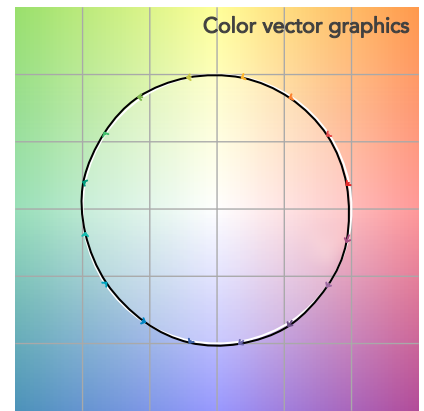
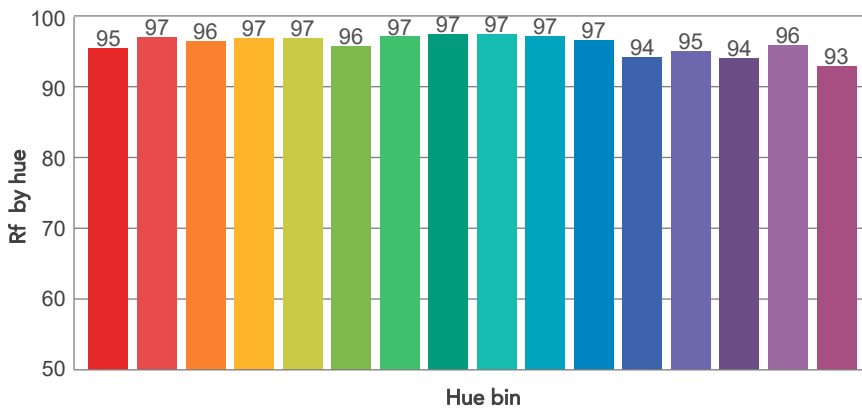
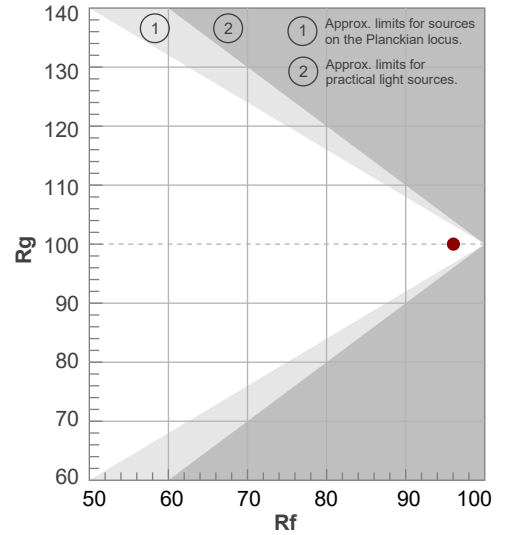

BEAM DETAILS



Beam angle 50%	Field angle 10%	Cut off angle 2,5%	Intensity ratio in 120° cone	Intensity ratio in 90° cone
26,1°	27,8°	28,1°	100,0%	100,0%

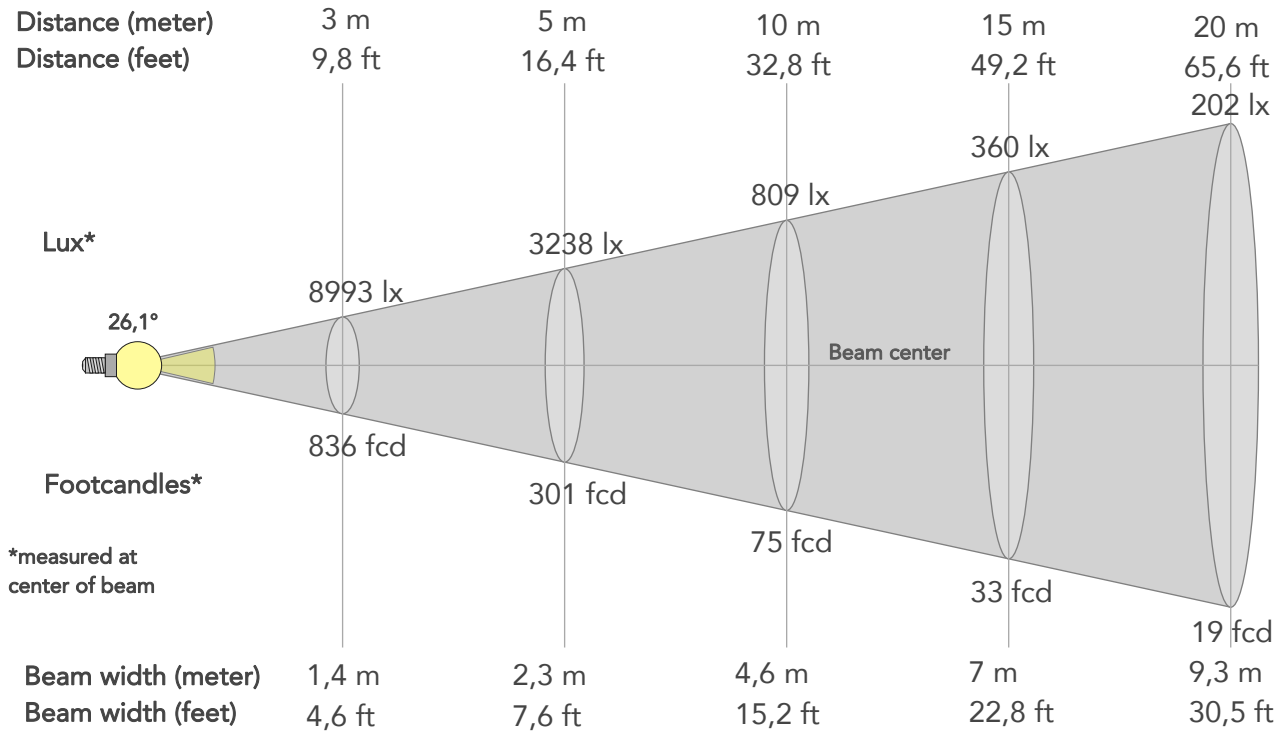

BEAM INTENSITIES AND WIDTHS

Distance	1m	2m	3m	4m	5m	7,5m	10m	15m	20m	25m	30m	40m	50m
Distance	3,3ft	6,6ft	9,8ft	13,1ft	16,4ft	24,6ft	32,8ft	49,2ft	65,6ft	82ft	98,4ft	131,2ft	164ft
Lux	80941lx	20235lx	8993lx	5059lx	3238lx	1439lx	809lx	360lx	202lx	130lx	90lx	51lx	32lx
Footcand.	7520fcd	1880fcd	836fcd	470fcd	301fcd	134fcd	75fcd	33fcd	19fcd	12fcd	8fcd	5fcd	3fcd
Beam wid.	0,5m	0,9m	1,4m	1,9m	2,3m	3,5m	4,6m	7m	9,3m	11,6m	13,9m	18,6m	23,2m
Beam wid.	1,5ft	3,1ft	4,6ft	6,1ft	7,6ft	11,4ft	15,2ft	22,8ft	30,5ft	38,1ft	45,7ft	60,9ft	76,2ft

LINEAR DISTRIBUTION DIAGRAM

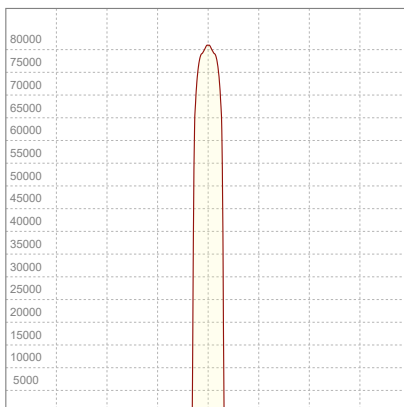

ELECTRICAL SPECIFICATIONS

Input voltage	Input current	Input power	Power FC	Efficiency
225V	1,77A	386,1W	0,97	32lm/W

ISO DIAGRAMS

ISO CANDELA DIAGRAM

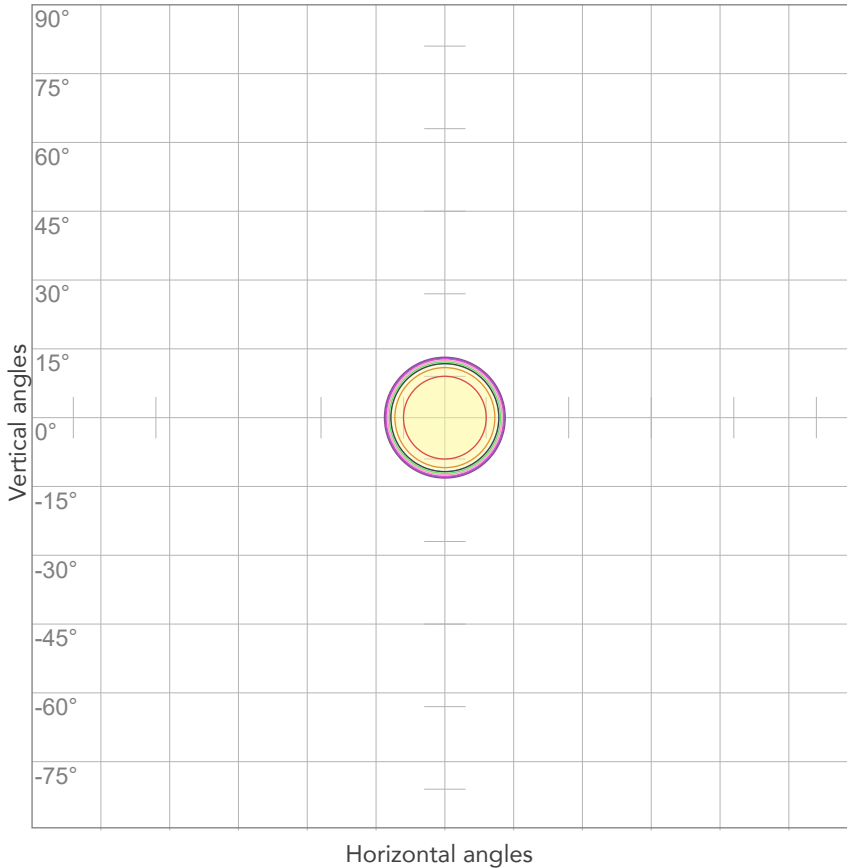

10%	8094 cd
20%	16188 cd
30%	24282 cd
40%	32376 cd
50%	40470 cd
60%	48565 cd
70%	56659 cd
80%	64753 cd

Conditions:

Number of c-planes: 2

Candela at center: 80941 cd

ISO LUX DIAGRAM

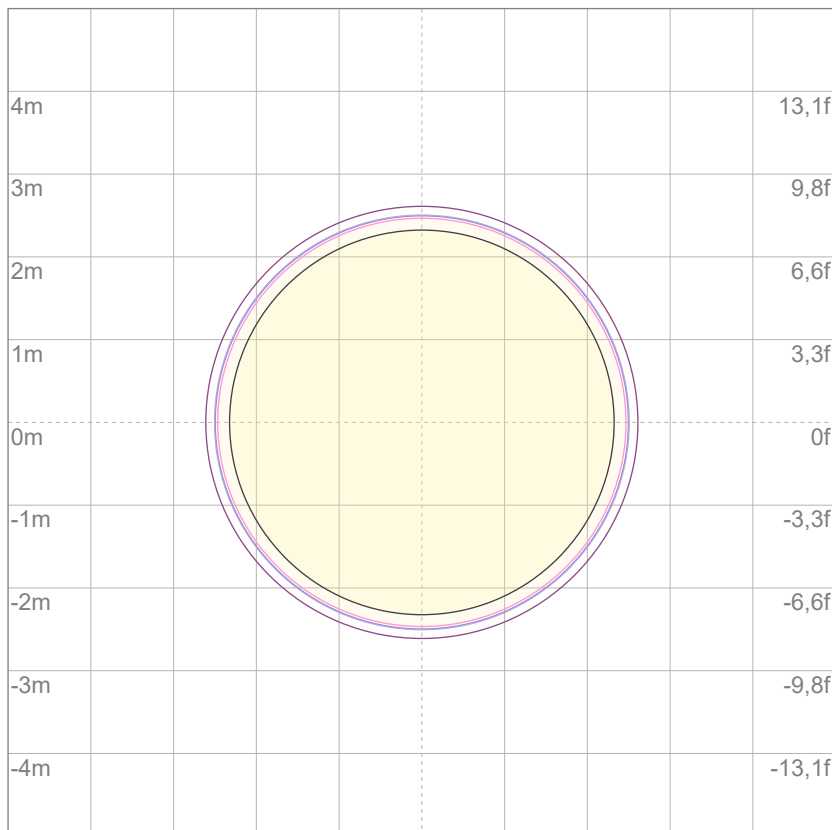

Mounting height: 10 meters (33 feet)

3%	24,3 lx
5%	40,5 lx
10%	80,9 lx
30%	243 lx
50%	405 lx

Conditions:

Number of c-planes: 2

Lux at center: 809 lx

Lux distribution on a surface when lamp is mounted at 10 meters from the surface.



Total lumen output:

15433 lm

Peak candela output:

105530 cd

Light quality:

CRI: 94,5

Color temperature:

6594 K

PRODUCT NAME:

ECLFWHPVW

MEASURAMENT CONDITIONS:

Beam angle:

PRL26

Target:

Cold White

Operator:

Giuseppe della Peruta

Date and time:

07/01/2026 11:05:51

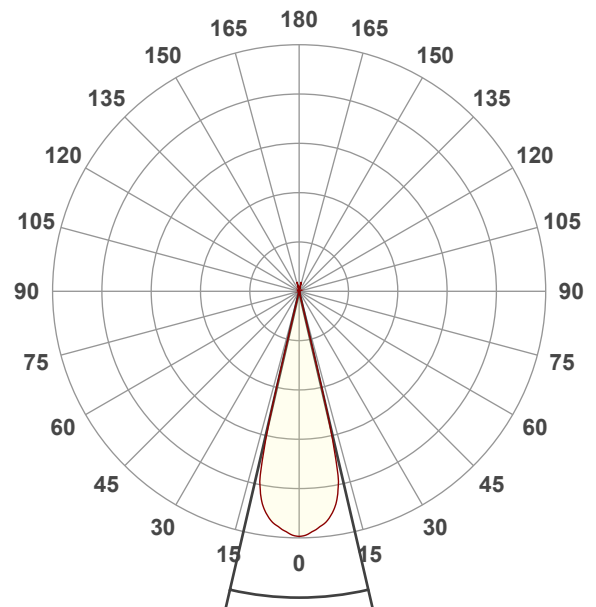

Beam angle 50%: 26,1°

Field angle 10%: 27,7°

Cut off angle 2.5%: 28°

Spectra

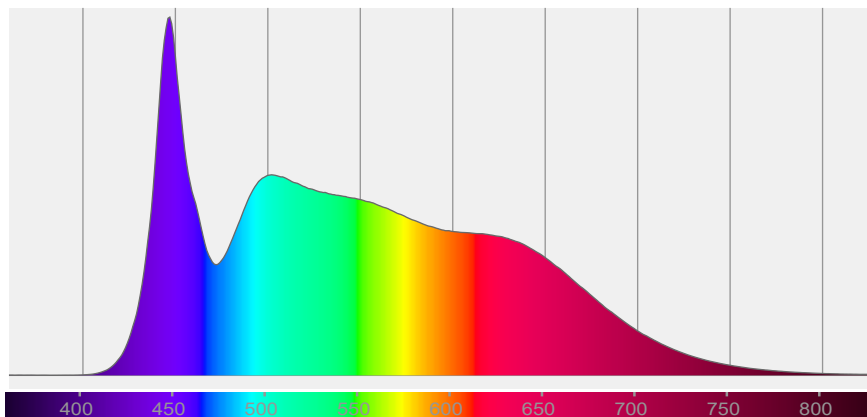

COLOR DETAILS

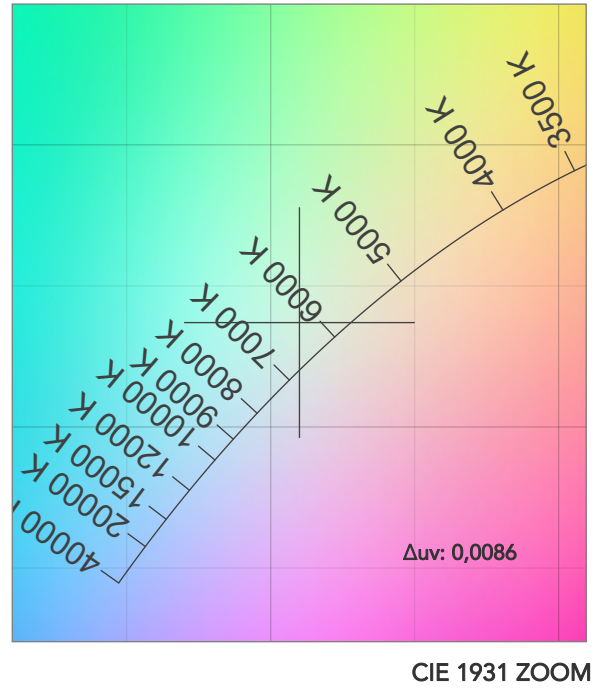
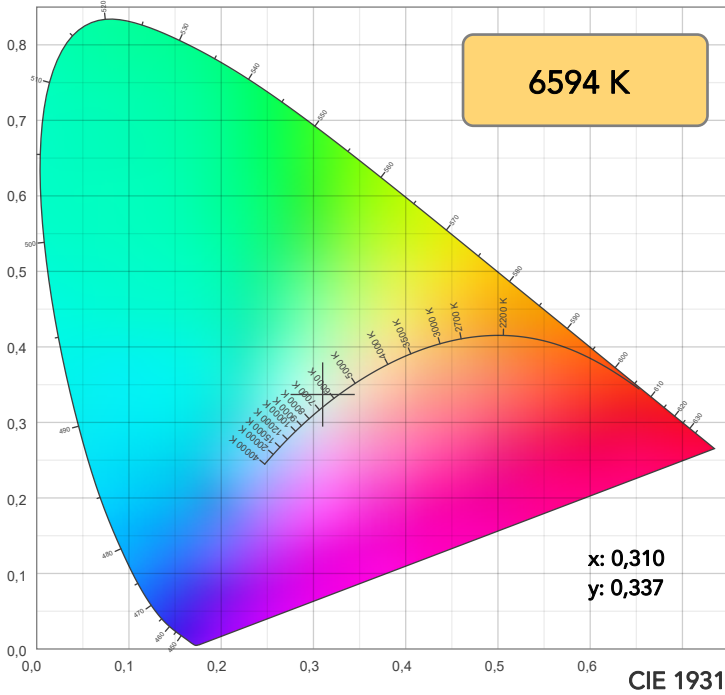

TM30: 94,2

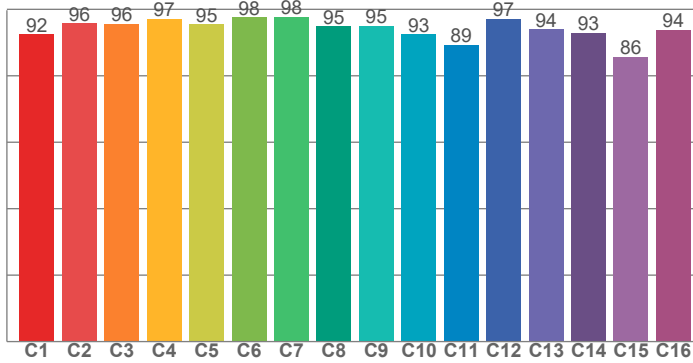

CRI: 94,5 (R1-R8)

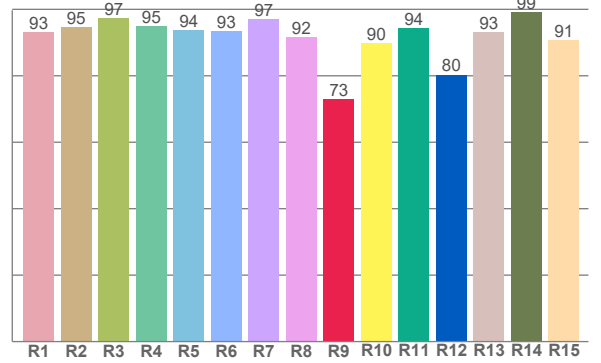

CRI R values, only R1-R8 are used to calculate final CRI value

R1	R2	R3	R4	R5	R6	R7	R8	R9	R10	R11	R12	R13	R14	R15
93,2	94,7	97,4	94,9	93,6	93,3	97,0	91,6	72,9	89,7	94,4	80,3	93,2	99,1	90,6

TM30 C values, 16 binned values out of total of 99 C values

C1	C2	C3	C4	C5	C6	C7	C8	C9	C10	C11	C12	C13	C14	C15	C16
92,4	95,8	95,7	97,1	95,4	97,6	97,7	94,8	95,1	92,5	89,3	97,1	93,9	92,9	85,7	93,8

CQS Q values

Q1	Q2	Q3	Q4	Q5	Q6	Q7	Q8	Q9	Q10	Q11	Q12	Q13	Q14	Q15
94,7	99,6	93,2	94,6	96,7	96,0	96,4	97,9	98,7	98,3	97,9	97,2	96,8	92,9	93,8

CQS: 95,8

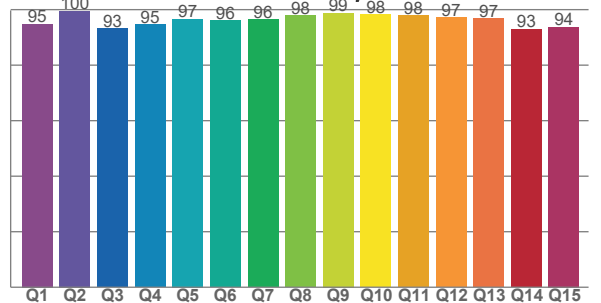

COLOR PARAMETERS

Color temperature	Color rendering index	Red component	Color fidelity	Color gamut	Color quality scale	Television lighting index	Color coordinate cie 1931	Color coordinate cie 1931	Color deviation from black body
CCT	CRI	CRI R9	TM30 Rf	TM30 Rg	CQS	TLCI	x	y	Δuv
6594 K	94,5	72,9	94,2	99,0	95,8	99	0,310	0,337	0,0086

TM30 DETAILS

Rf 94,2
Fidelity index Rf

Rg 99,0
Gammut index

Hue Bin	R _f	Graphic shifts (%)	
		Chroma	Hue
1	92	-3%	-2%
2	96	-2%	0%
3	96	-2%	1%
4	97	-1%	0%
5	95	-2%	0%
6	98	0%	0%
7	98	0%	0%
8	95	-2%	0%
9	95	-2%	3%
10	93	-1%	5%
11	89	1%	6%
12	97	2%	1%
13	94	4%	-2%
14	93	1%	-4%
15	86	6%	-11%
16	94	-1%	-3%

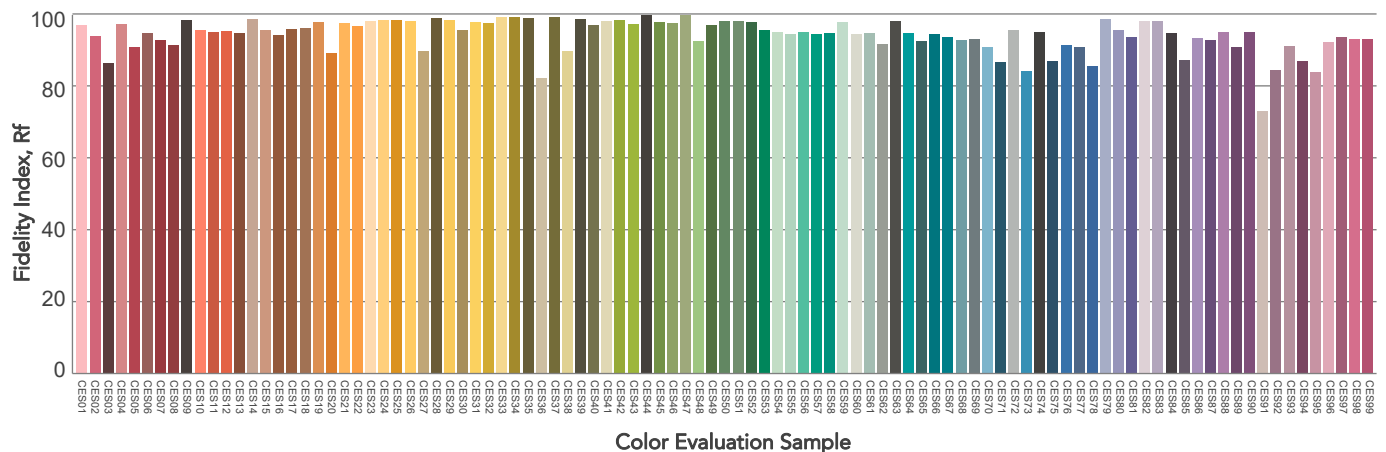
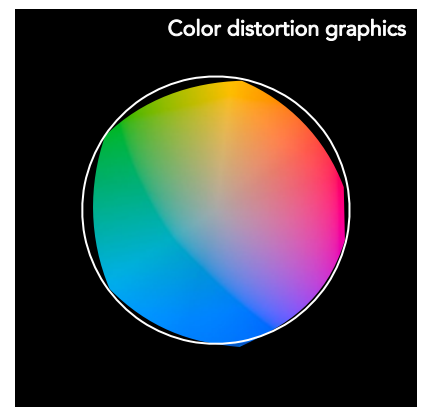
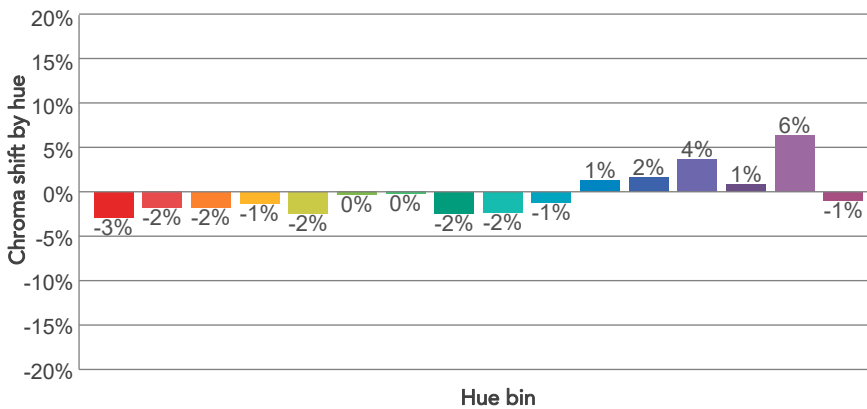
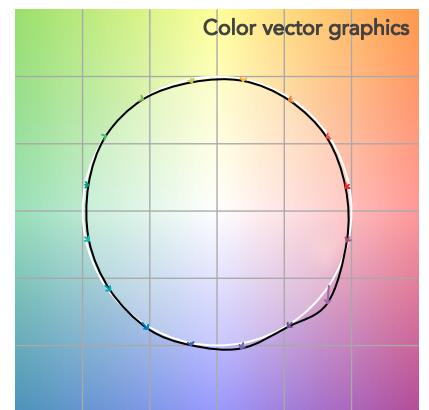
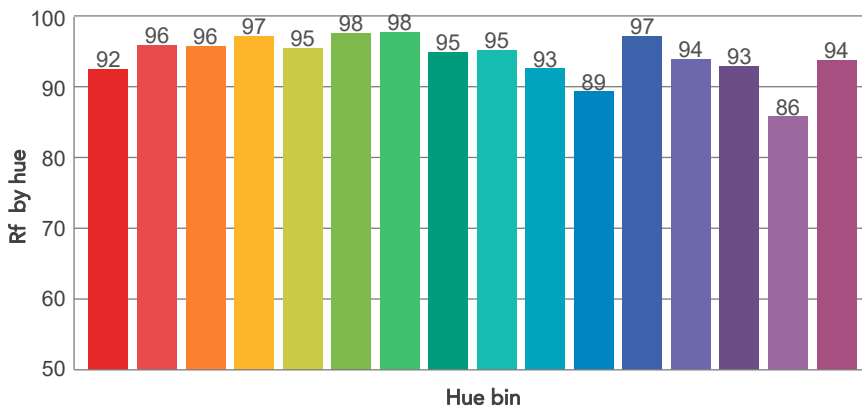
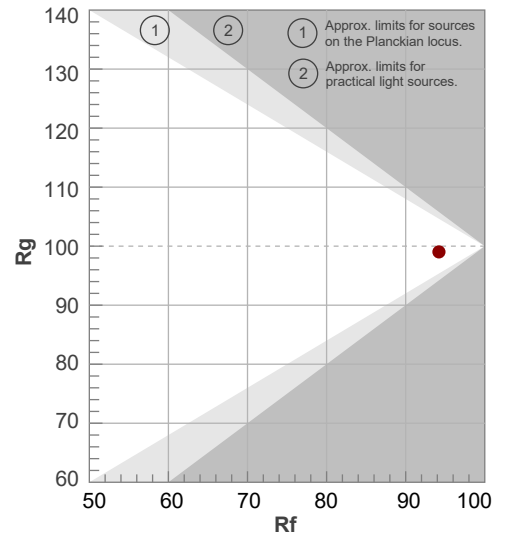

BEAM DETAILS



Beam angle 50%	Field angle 10%	Cut off angle 2,5%	Intensity ratio in 120° cone	Intensity ratio in 90° cone
26,1°	27,7°	28°	100,0%	100,0%

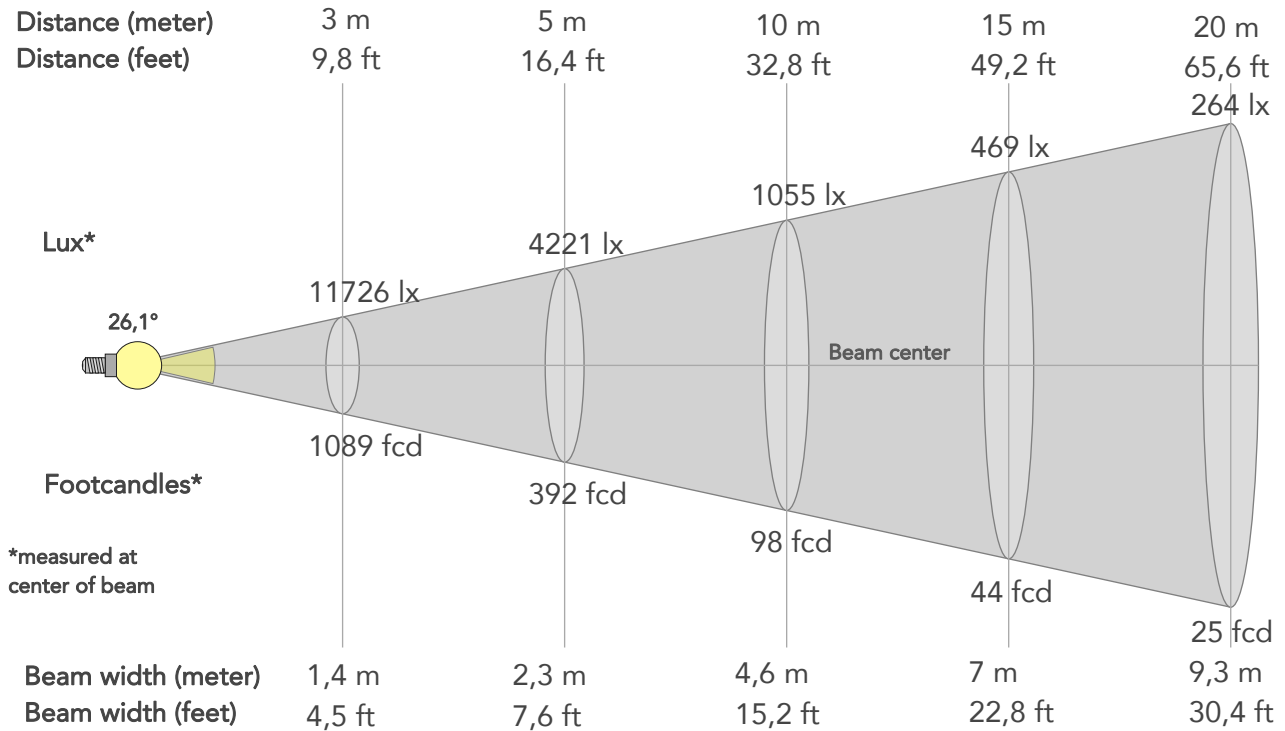

BEAM INTENSITIES AND WIDTHS

Distance	1m	2m	3m	4m	5m	7,5m	10m	15m	20m	25m	30m	40m	50m
Distance	3,3ft	6,6ft	9,8ft	13,1ft	16,4ft	24,6ft	32,8ft	49,2ft	65,6ft	82ft	98,4ft	131,2ft	164ft
Lux	105530lx	26382lx	11726lx	6596lx	4221lx	1876lx	1055lx	469lx	264lx	169lx	117lx	66lx	42lx
Footcand.	9804fcd	2451fcd	1089fcd	613fcd	392fcd	174fcd	98fcd	44fcd	25fcd	16fcd	11fcd	6fcd	4fcd
Beam wid.	0,5m	0,9m	1,4m	1,9m	2,3m	3,5m	4,6m	7m	9,3m	11,6m	13,9m	18,5m	23,2m
Beam wid.	1,5ft	3,1ft	4,5ft	6,1ft	7,6ft	11,4ft	15,2ft	22,8ft	30,4ft	38ft	45,6ft	60,8ft	76ft

LINEAR DISTRIBUTION DIAGRAM

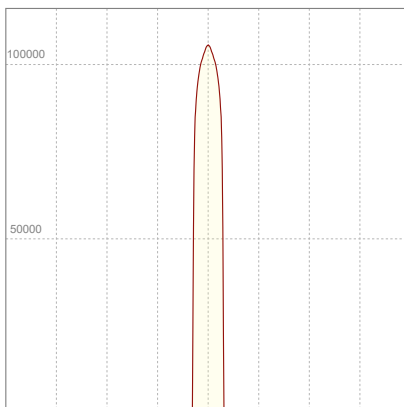

ELECTRICAL SPECIFICATIONS

Input voltage	Input current	Input power	Power FC	Efficiency
225V	1,76A	382,5W	0,97	40lm/W

ISO DIAGRAMS

ISO CANDELA DIAGRAM

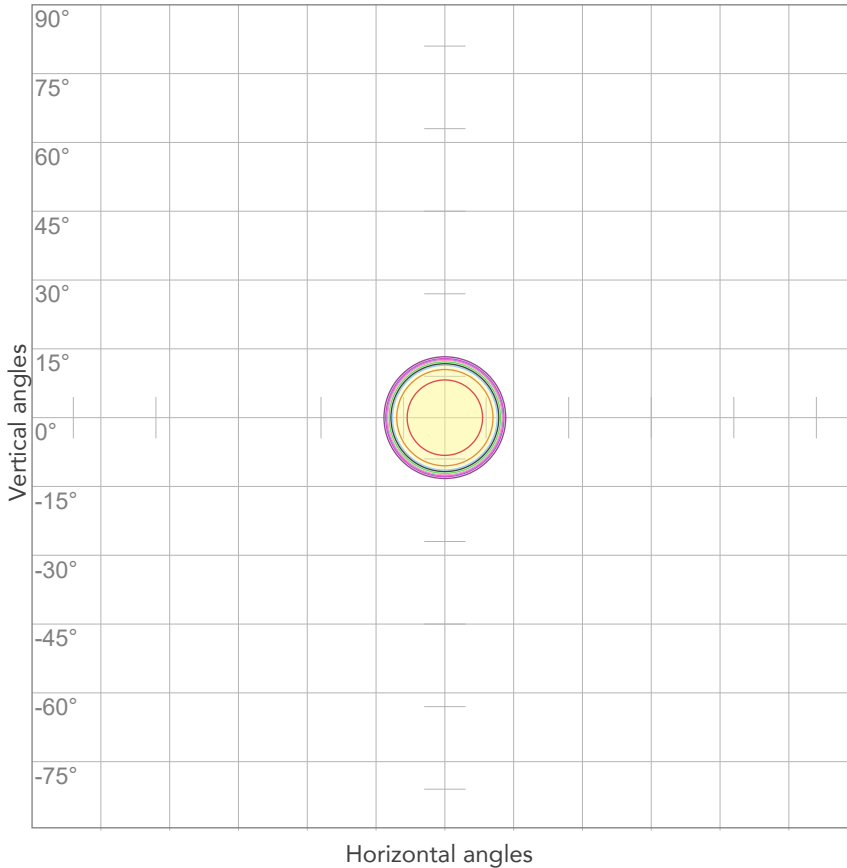

10%	10553 cd
20%	21106 cd
30%	31659 cd
40%	42212 cd
50%	52765 cd
60%	63318 cd
70%	73871 cd
80%	84424 cd

Conditions:

Number of c-planes: 2

Candela at center: 105530 cd

ISO LUX DIAGRAM

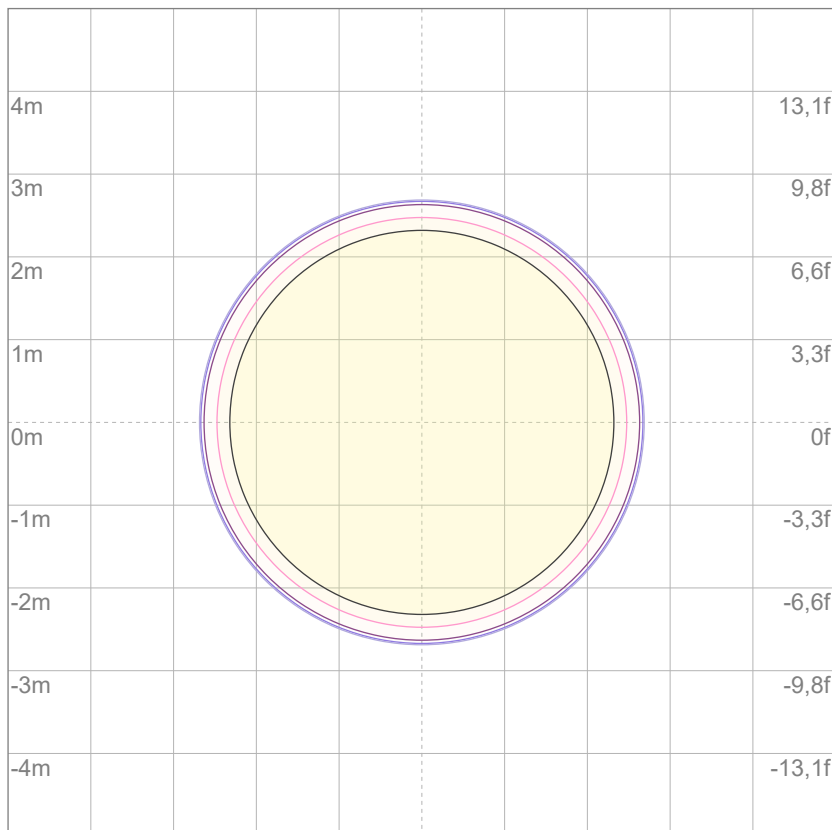

3%	31,7 lx
5%	52,8 lx
10%	106 lx
30%	317 lx
50%	528 lx

Conditions:

Number of c-planes: 2

Lux at center: 1055 lx

Lux distribution on a surface when lamp is mounted at 10 meters from the surface.

Mounting height: 10 meters (33 feet)



Total lumen output:

13231 lm

Peak candela output:

88494 cd

Light quality:

CRI: 97,6

Color temperature:

2803 K

PRODUCT NAME:

ECLFWHPVW

MEASUREMENT CONDITIONS:

Beam angle:

PRL26

Target:

2800K

Operator:

Giuseppe della Peruta

Date and time:

07/01/2026 11:11:02

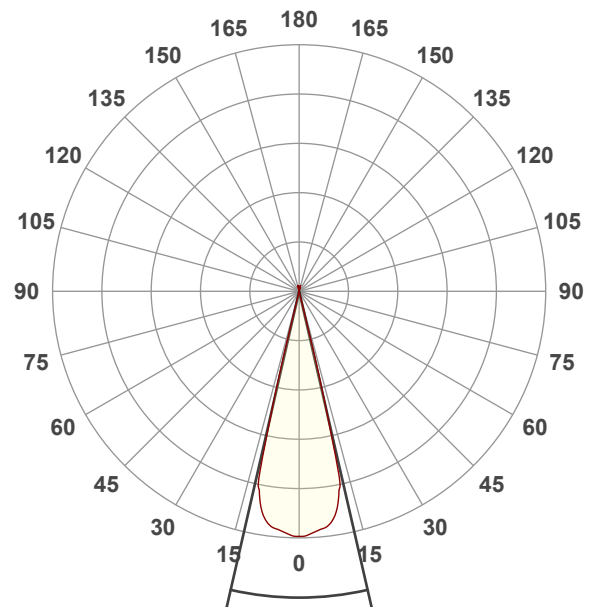

Beam angle 50%: 25,8°

Field angle 10%: 28°

Cut off angle 2.5%: 28,4°

Spectra

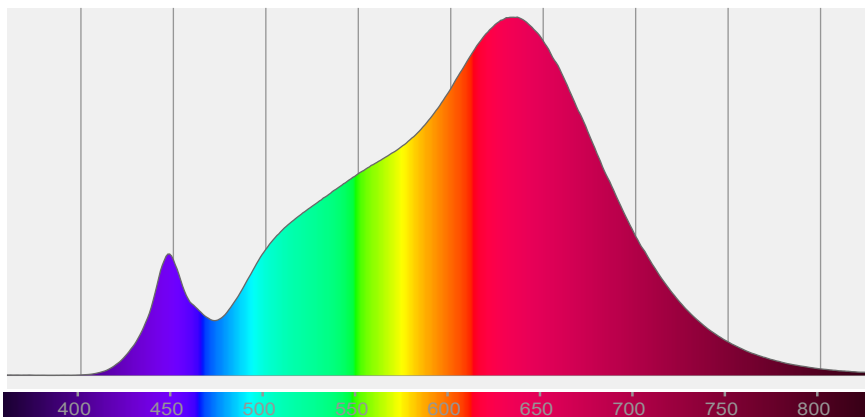

COLOR DETAILS

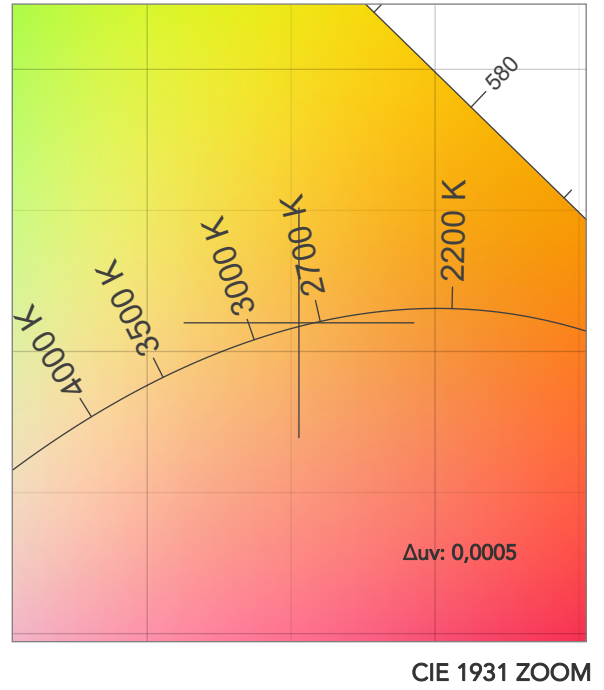
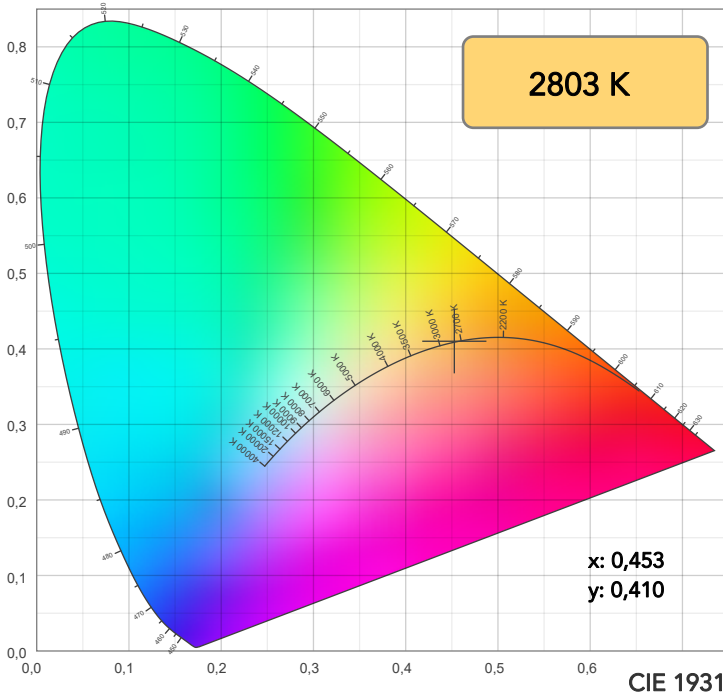

TM30: 95,7

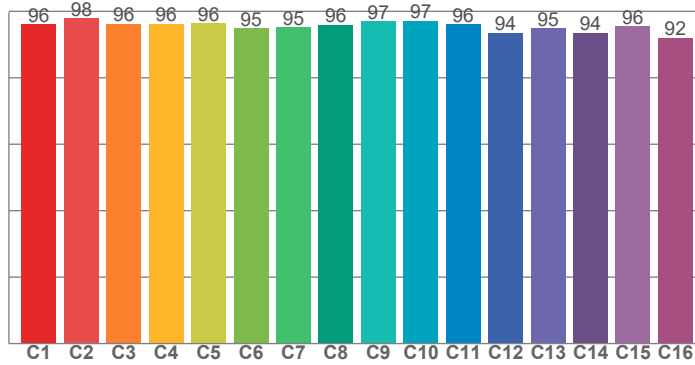

CRI: 97,6 (R1-R8)

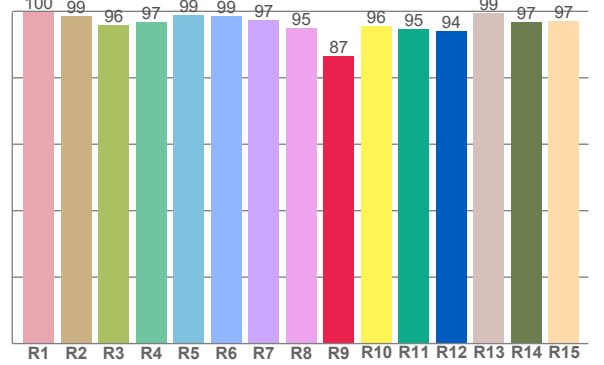

CQS: 94,8

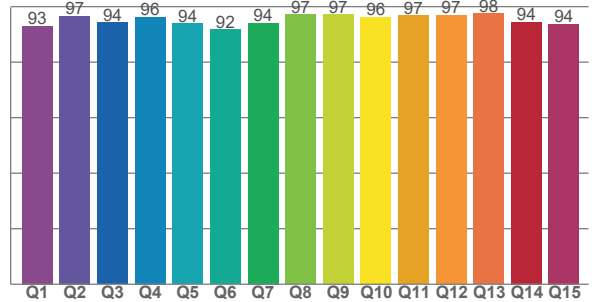

CRI R values, only R1-R8 are used to calculate final CRI value

R1	R2	R3	R4	R5	R6	R7	R8	R9	R10	R11	R12	R13	R14	R15
99,6	98,5	95,8	96,8	98,9	98,7	97,4	94,9	86,6	95,6	94,6	93,9	99,4	96,7	96,9

TM30 C values, 16 binned values out of total of 99 C values

C1	C2	C3	C4	C5	C6	C7	C8	C9	C10	C11	C12	C13	C14	C15	C16
96,1	97,9	96,2	96,2	96,3	94,9	95,2	95,9	97,0	97,1	96,1	93,6	94,9	93,5	95,5	92,1

CQS Q values

Q1	Q2	Q3	Q4	Q5	Q6	Q7	Q8	Q9	Q10	Q11	Q12	Q13	Q14	Q15
93,1	96,7	94,2	96,3	93,9	91,7	94,1	97,1	97,2	96,3	96,7	96,9	97,5	94,4	93,8

COLOR PARAMETERS

Color temperature	Color rendering index	Red component	Color fidelity	Color gamut	Color quality scale	Television lighting index	Color coordinate cie 1931	Color coordinate cie 1931	Color deviation from black body
CCT	CRI	CRI R9	TM30 Rf	TM30 Rg	CQS	TLCI	x	y	Δuv
2803 K	97,6	86,6	95,7	102,0	94,8	96	0,453	0,410	0,0005

TM30 DETAILS

Rf 95,7
Fidelity index Rf

Rg 102,0
Gammut index

Hue Bin	R _f	Graphic shifts (%)	
		Chroma	Hue
1	96	-1%	-1%
2	98	-1%	0%
3	96	0%	2%
4	96	1%	1%
5	96	2%	2%
6	95	3%	1%
7	95	2%	-2%
8	96	2%	-2%
9	97	0%	-2%
10	97	-1%	0%
11	96	0%	2%
12	94	3%	0%
13	95	2%	-3%
14	94	3%	-4%
15	96	1%	-3%
16	92	0%	-6%

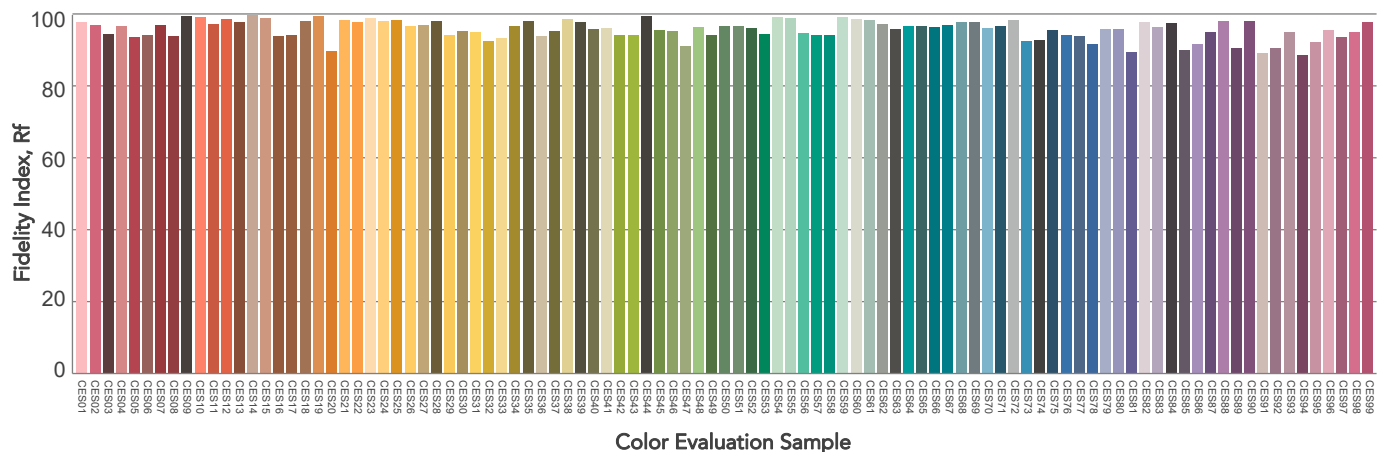
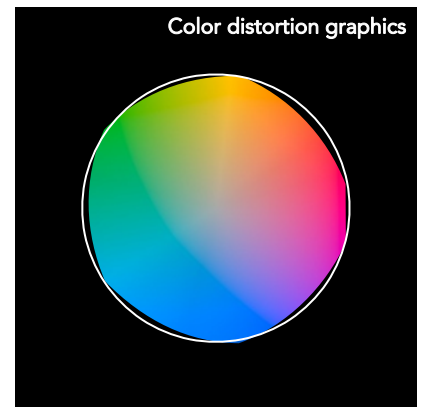
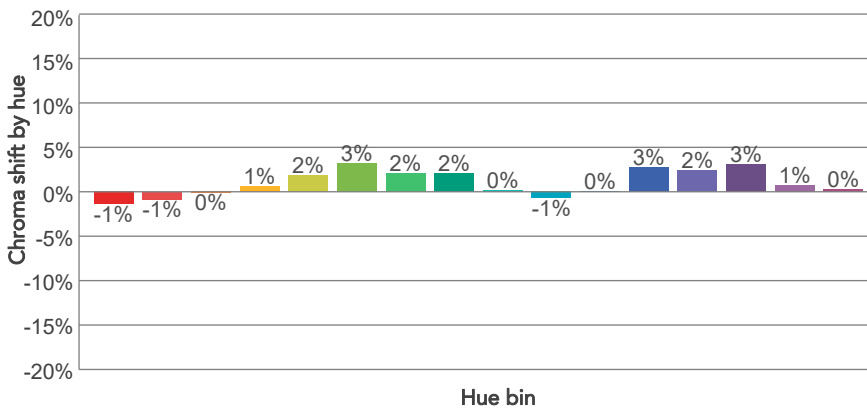
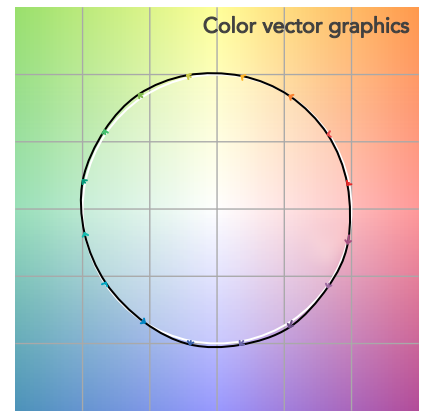
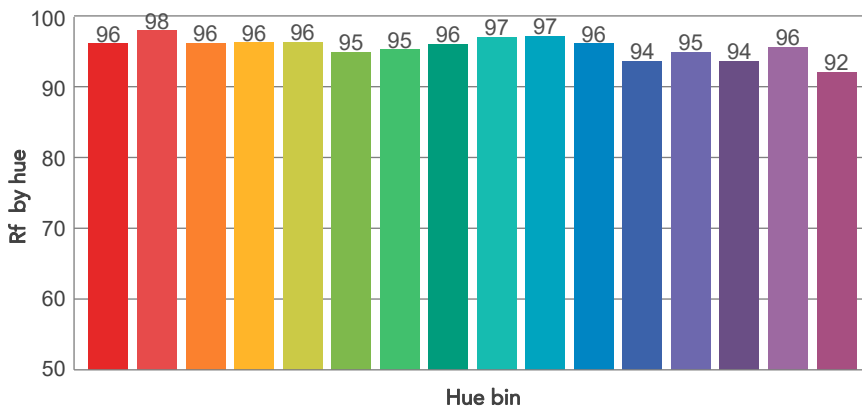
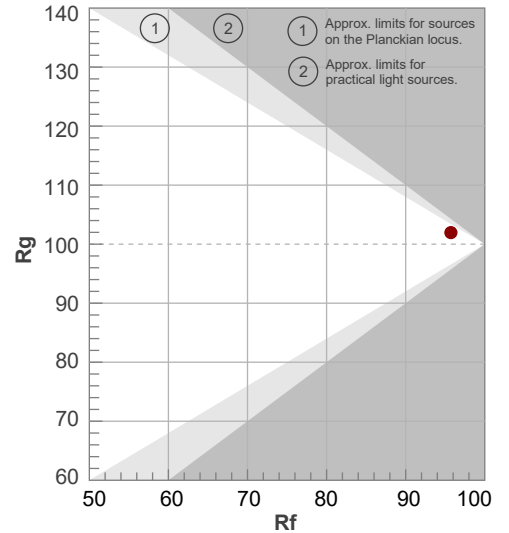

BEAM DETAILS



Beam angle 50%	Field angle 10%	Cut off angle 2,5%	Intensity ratio in 120° cone	Intensity ratio in 90° cone
25,8°	28°	28,4°	100,0%	100,0%

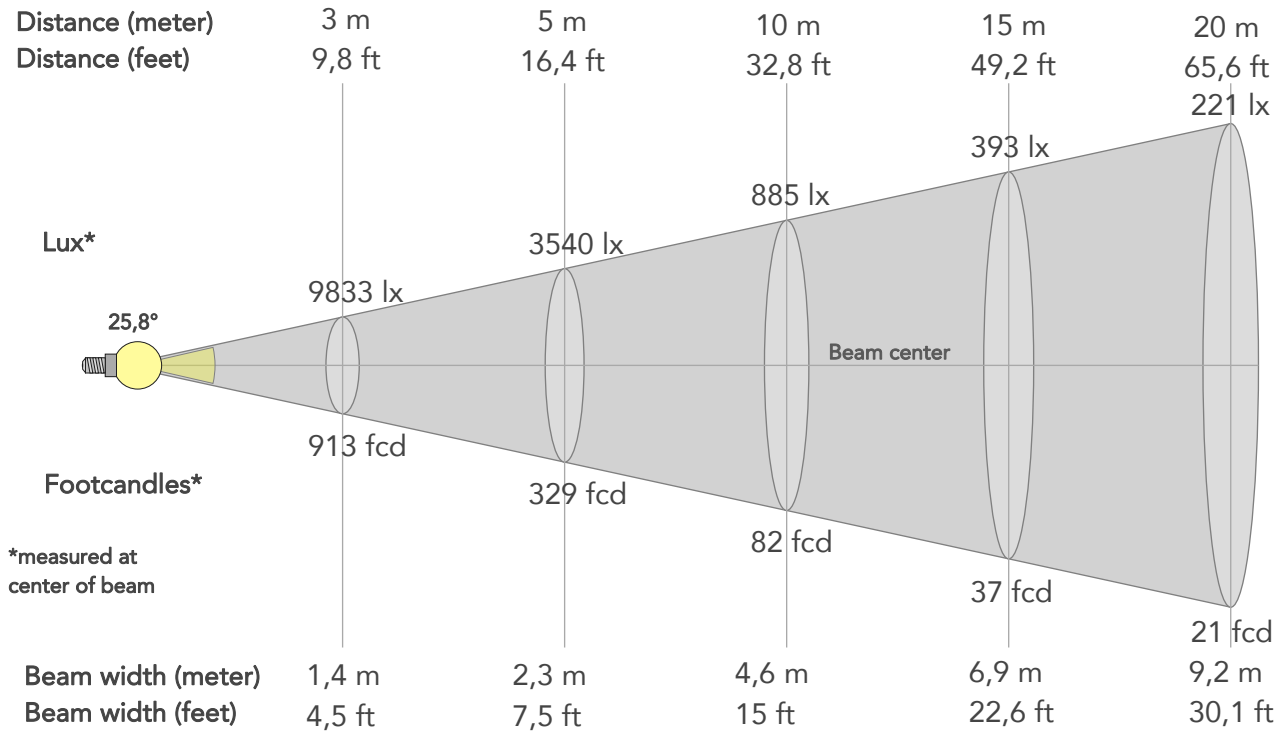

BEAM INTENSITIES AND WIDTHS

Distance	1m	2m	3m	4m	5m	7,5m	10m	15m	20m	25m	30m	40m	50m
Distance	3,3ft	6,6ft	9,8ft	13,1ft	16,4ft	24,6ft	32,8ft	49,2ft	65,6ft	82ft	98,4ft	131,2ft	164ft
Lux	88494lx	22124lx	9833lx	5531lx	3540lx	1573lx	885lx	393lx	221lx	142lx	98lx	55lx	35lx
Footcand.	8221fcd	2055fcd	913fcd	514fcd	329fcd	146fcd	82fcd	37fcd	21fcd	13fcd	9fcd	5fcd	3fcd
Beam wid.	0,5m	0,9m	1,4m	1,8m	2,3m	3,4m	4,6m	6,9m	9,2m	11,5m	13,8m	18,3m	22,9m
Beam wid.	1,5ft	3ft	4,5ft	6ft	7,5ft	11,3ft	15ft	22,6ft	30,1ft	37,6ft	45,1ft	60,2ft	75,2ft

LINEAR DISTRIBUTION DIAGRAM

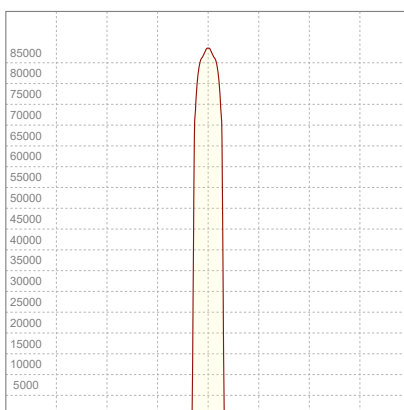

ELECTRICAL SPECIFICATIONS

Input voltage	Input current	Input power	Power FC	Efficiency
225V	1,88A	410,8W	0,97	32lm/W

ISO DIAGRAMS

ISO CANDELA DIAGRAM

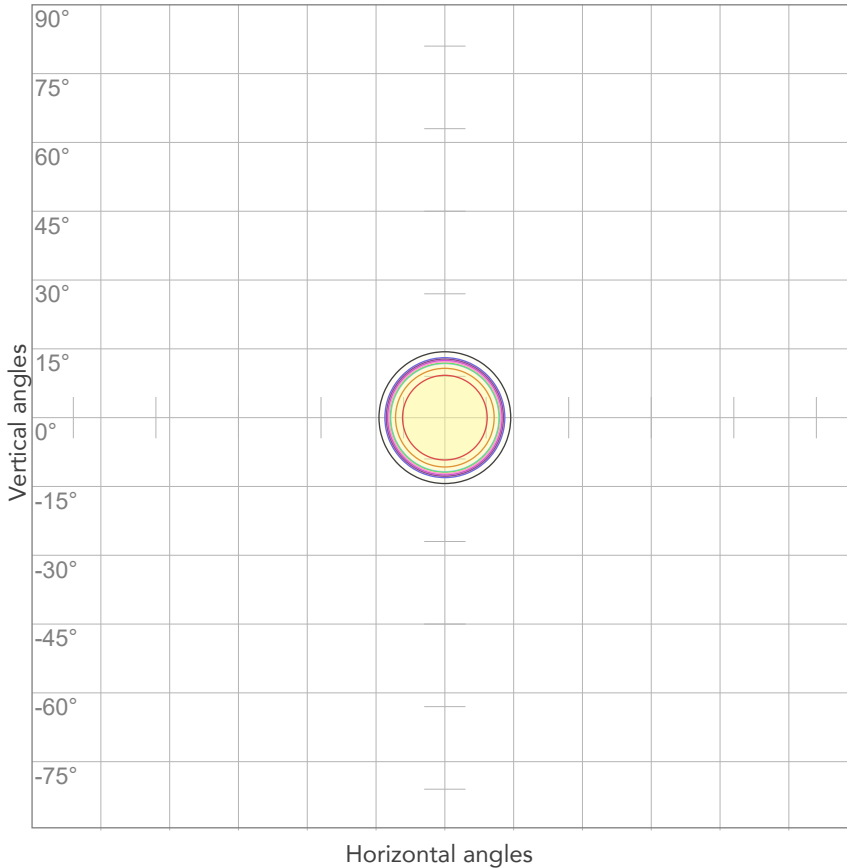

10%	8849 cd
20%	17699 cd
30%	26548 cd
40%	35398 cd
50%	44247 cd
60%	53097 cd
70%	61946 cd
80%	70796 cd

Conditions:

Number of c-planes: 2

Candela at center: 88494 cd

ISO LUX DIAGRAM

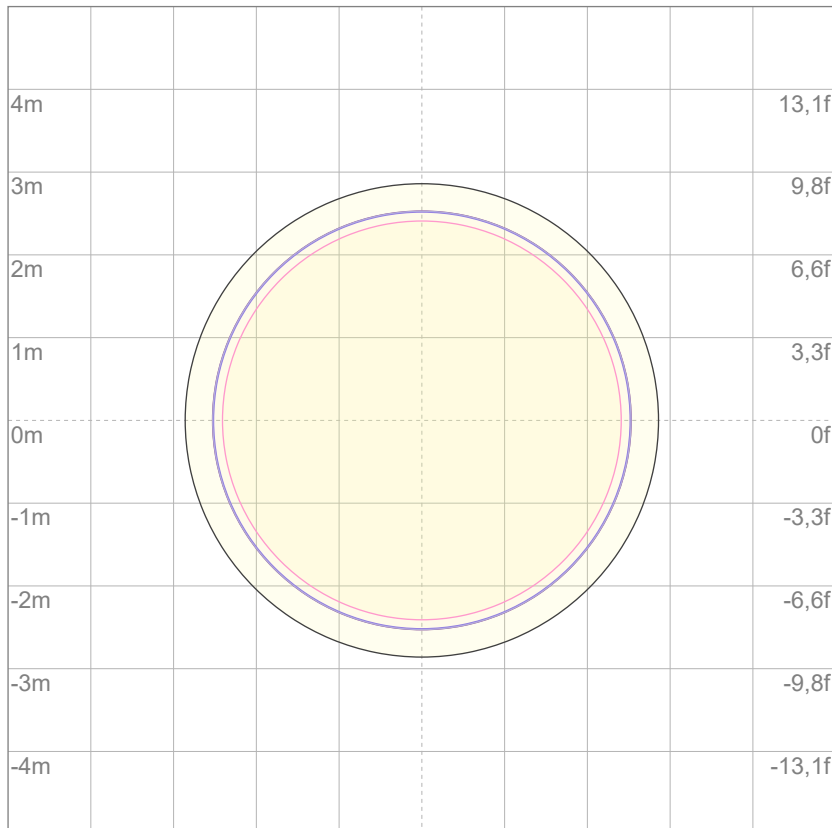

Mounting height: 10 meters (33 feet)

3%	26,5 lx
5%	44,2 lx
10%	88,5 lx
30%	265 lx
50%	442 lx

Conditions:

Number of c-planes: 2

Lux at center: 885 lx

Lux distribution on a surface when lamp is mounted at 10 meters from the surface.



Total lumen output:

14679 lm

Peak candela output:

98620 cd

Light quality:

CRI: 97,6

Color temperature:

3198 K

PRODUCT NAME:

ECLFWHPVW

MEASUREMENT CONDITIONS:

Beam angle:

PRL26

Target:

3200K

Operator:

Giuseppe della Peruta

Date and time:

07/01/2026 11:30:33

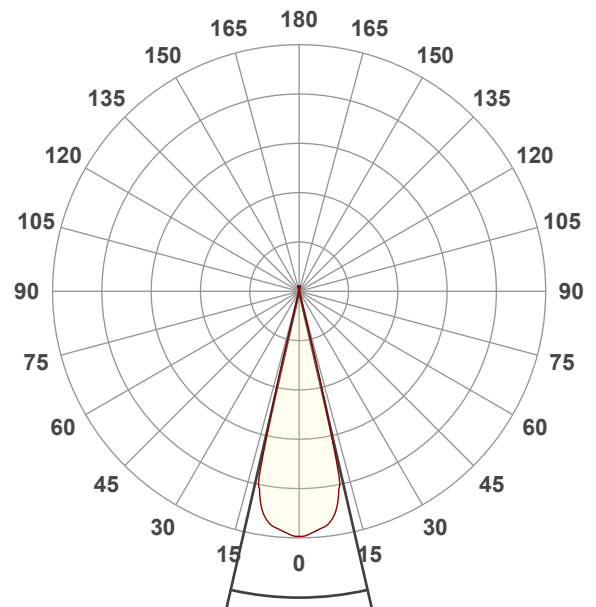

Beam angle 50%: 25,8°

Field angle 10%: 28°

Cut off angle 2.5%: 28,4°

Spectra

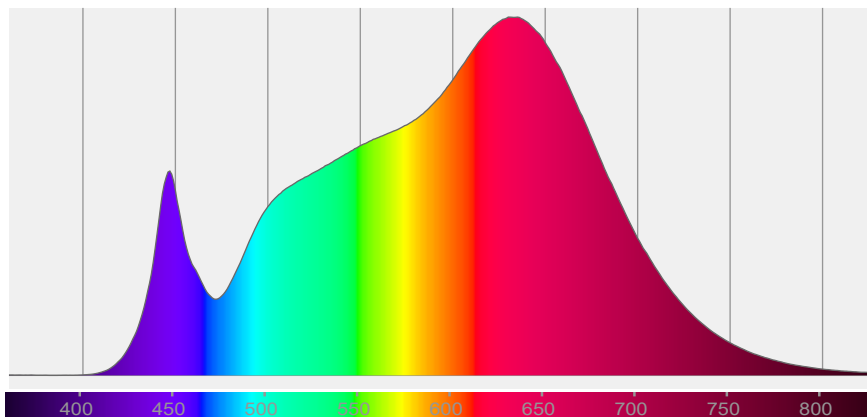

COLOR DETAILS

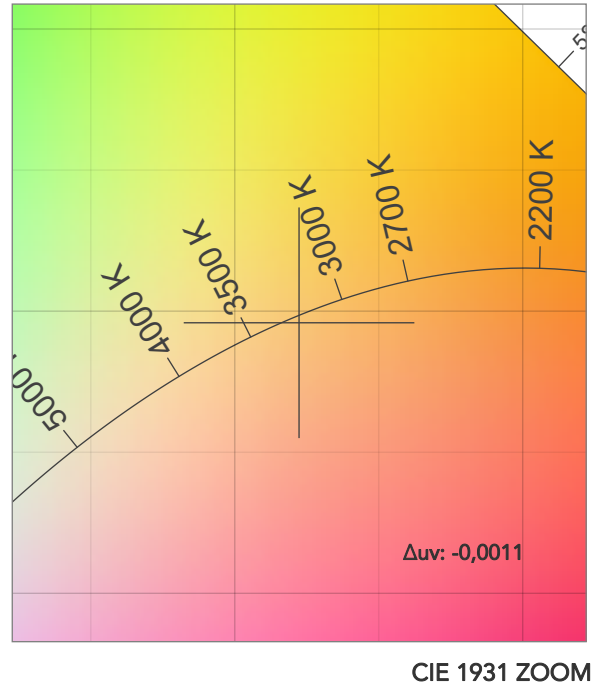
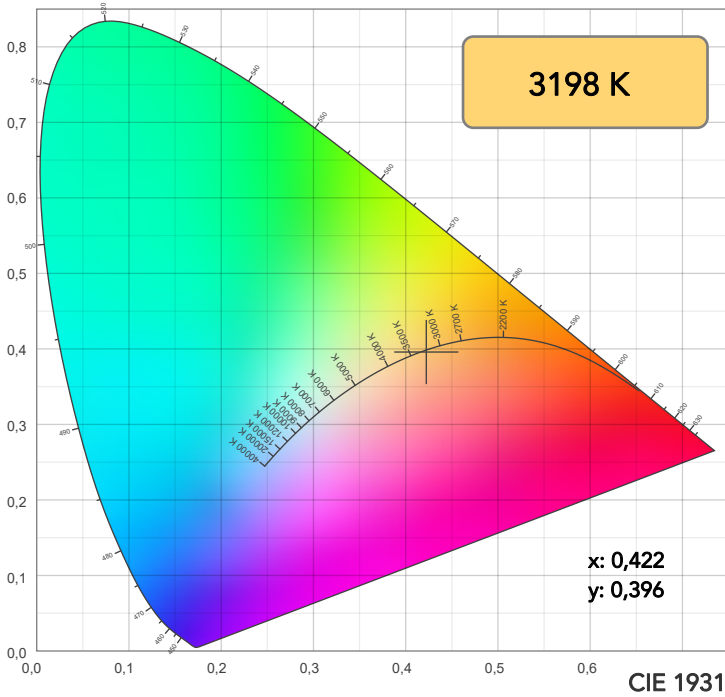

TM30: 95,8

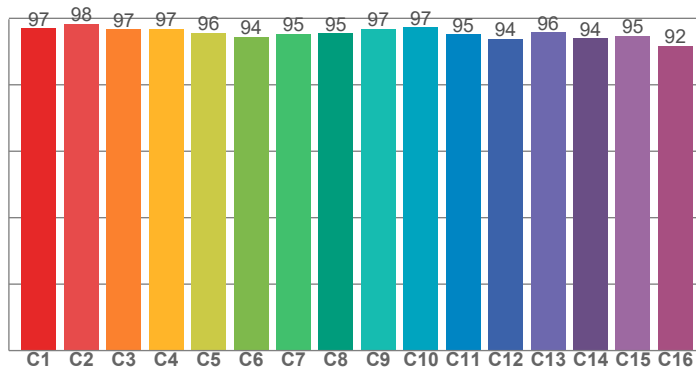

CRI: 97,6 (R1-R8)

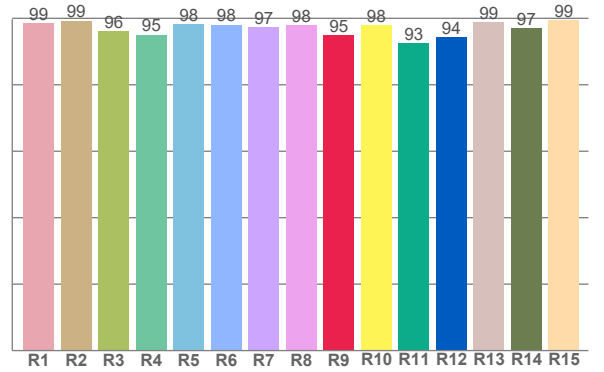

CRI R values, only R1-R8 are used to calculate final CRI value

R1	R2	R3	R4	R5	R6	R7	R8	R9	R10	R11	R12	R13	R14	R15
98,5	99,3	96,1	95,1	98,2	98,1	97,4	97,9	95,0	98,1	92,6	94,3	98,9	97,1	99,4

TM30 C values, 16 binned values out of total of 99 C values

C1	C2	C3	C4	C5	C6	C7	C8	C9	C10	C11	C12	C13	C14	C15	C16
96,9	98,4	96,6	96,8	95,7	94,4	95,4	95,5	96,8	97,3	95,1	93,8	95,8	94,0	94,8	91,7

CQS Q values

Q1	Q2	Q3	Q4	Q5	Q6	Q7	Q8	Q9	Q10	Q11	Q12	Q13	Q14	Q15
95,5	98,2	94,0	97,5	94,6	91,9	94,7	98,0	97,7	96,9	98,3	98,5	98,5	97,3	96,7

CQS: 95,8

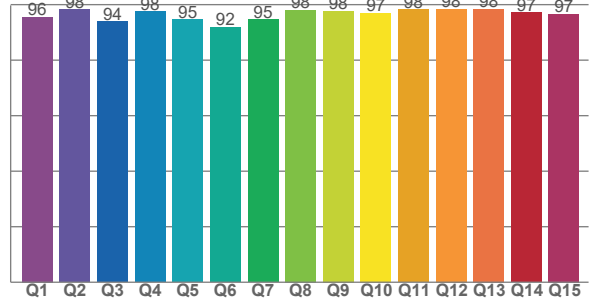

COLOR PARAMETERS

Color temperature	Color rendering index	Red component	Color fidelity	Color gamut	Color quality scale	Television lighting index	Color coordinate cie 1931	Color coordinate cie 1931	Color deviation from black body
CCT	CRI	CRI R9	TM30 Rf	TM30 Rg	CQS	TLCI	x	y	Δuv
3198 K	97,6	95,0	95,8	103,2	95,8	97	0,422	0,396	-0,0011

TM30 DETAILS

Rf 95,8
Fidelity index Rf

Rg 103,2
Gammut index

Hue Bin	R _f	Graphic shifts (%)	
		Chroma	Hue
1	97	0%	-1%
2	98	0%	0%
3	97	0%	2%
4	97	1%	1%
5	96	1%	2%
6	94	4%	1%
7	95	3%	-1%
8	95	2%	-2%
9	97	1%	-1%
10	97	0%	-1%
11	95	1%	3%
12	94	3%	0%
13	96	2%	-2%
14	94	4%	-3%
15	95	2%	-3%
16	92	2%	-7%

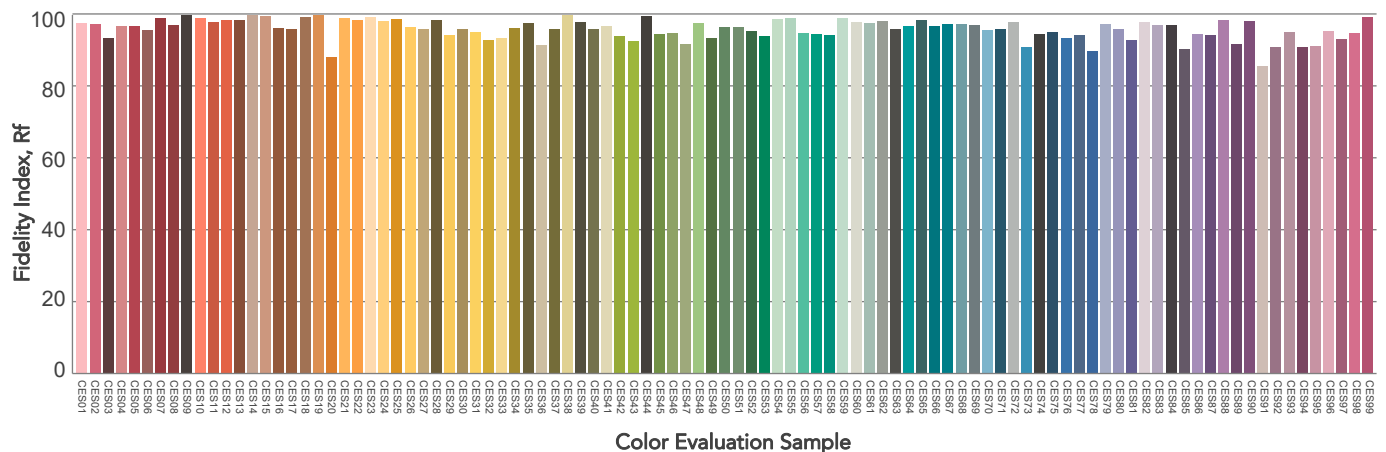
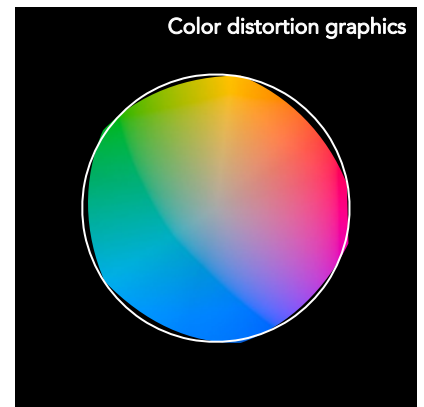
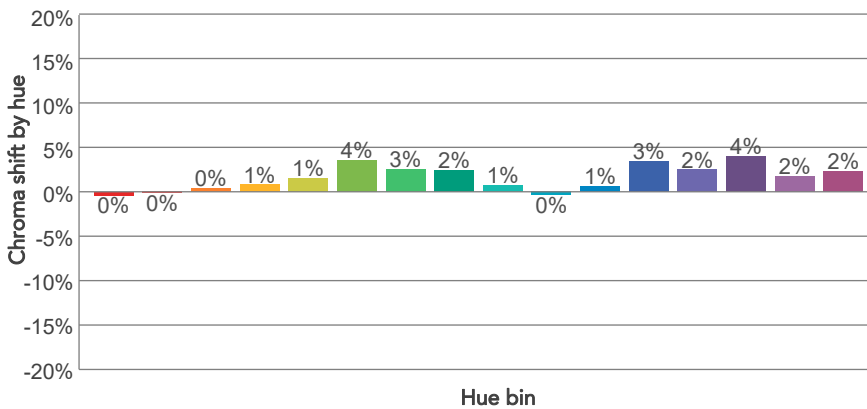
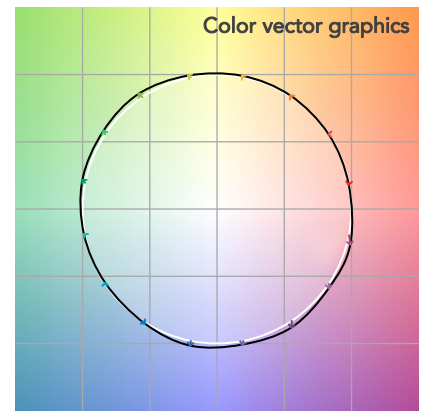
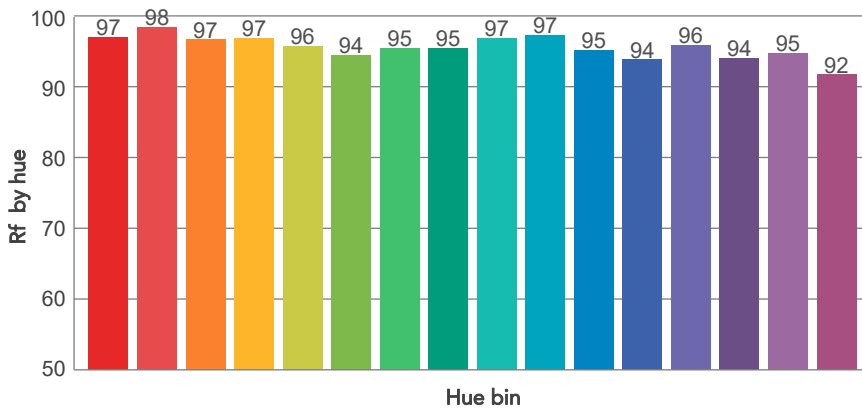
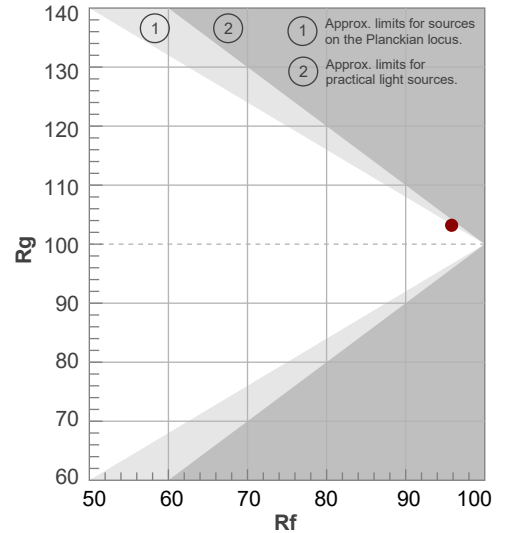

BEAM DETAILS



Beam angle 50%	Field angle 10%	Cut off angle 2,5%	Intensity ratio in 120° cone	Intensity ratio in 90° cone
25,8°	28°	28,4°	100,0%	100,0%

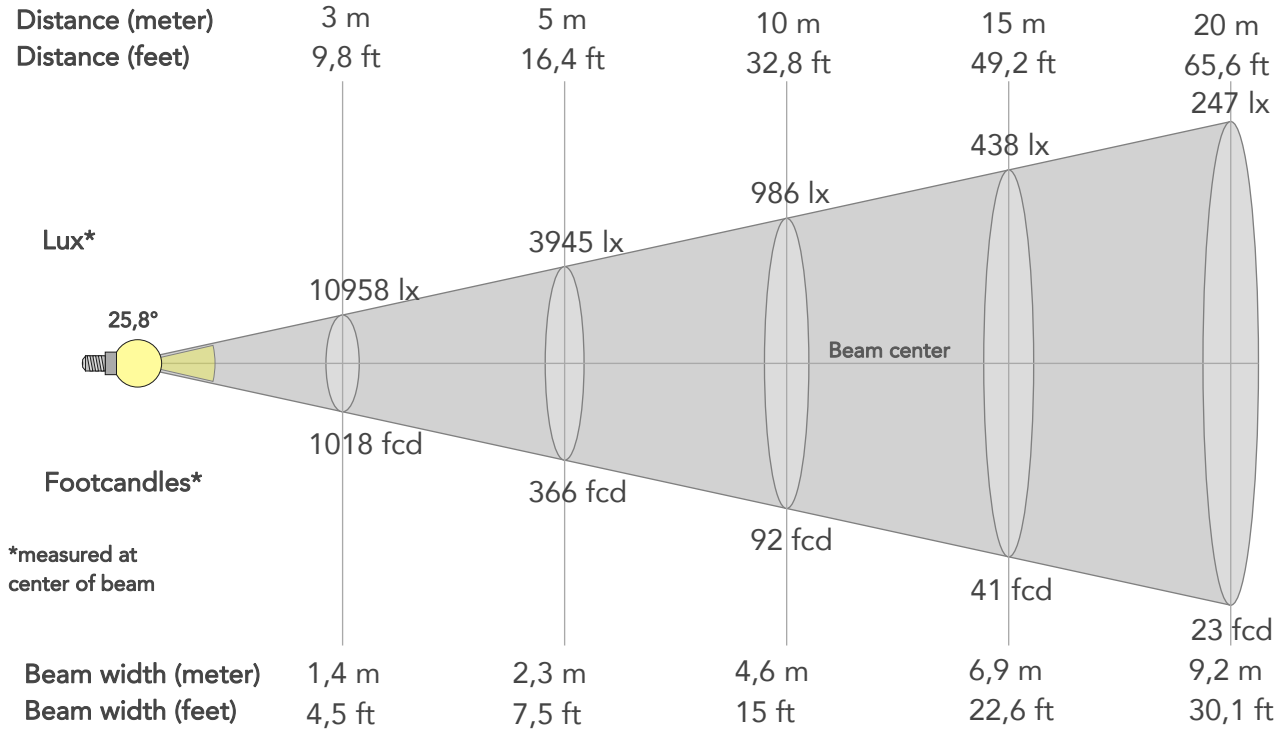

BEAM INTENSITIES AND WIDTHS

Distance	1m	2m	3m	4m	5m	7,5m	10m	15m	20m	25m	30m	40m	50m
Distance	3,3ft	6,6ft	9,8ft	13,1ft	16,4ft	24,6ft	32,8ft	49,2ft	65,6ft	82ft	98,4ft	131,2ft	164ft
Lux	98620lx	24655lx	10958lx	6164lx	3945lx	1753lx	986lx	438lx	247lx	158lx	110lx	62lx	39lx
Footcand.	9162fcd	2291fcd	1018fcd	573fcd	366fcd	163fcd	92fcd	41fcd	23fcd	15fcd	10fcd	6fcd	4fcd
Beam wid.	0,5m	0,9m	1,4m	1,8m	2,3m	3,4m	4,6m	6,9m	9,2m	11,5m	13,8m	18,3m	22,9m
Beam wid.	1,5ft	3ft	4,5ft	6ft	7,5ft	11,3ft	15ft	22,6ft	30,1ft	37,6ft	45,1ft	60,1ft	75,2ft

LINEAR DISTRIBUTION DIAGRAM

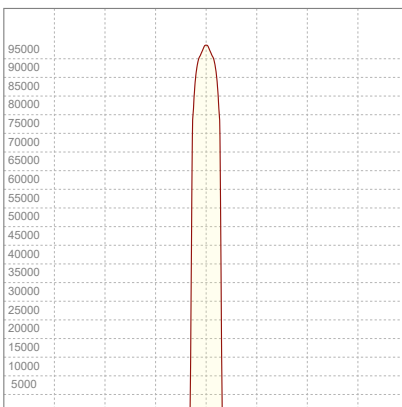

ELECTRICAL SPECIFICATIONS

Input voltage	Input current	Input power	Power FC	Efficiency
225V	1,99A	436,3W	0,97	34lm/W

ISO DIAGRAMS

ISO CANDELA DIAGRAM

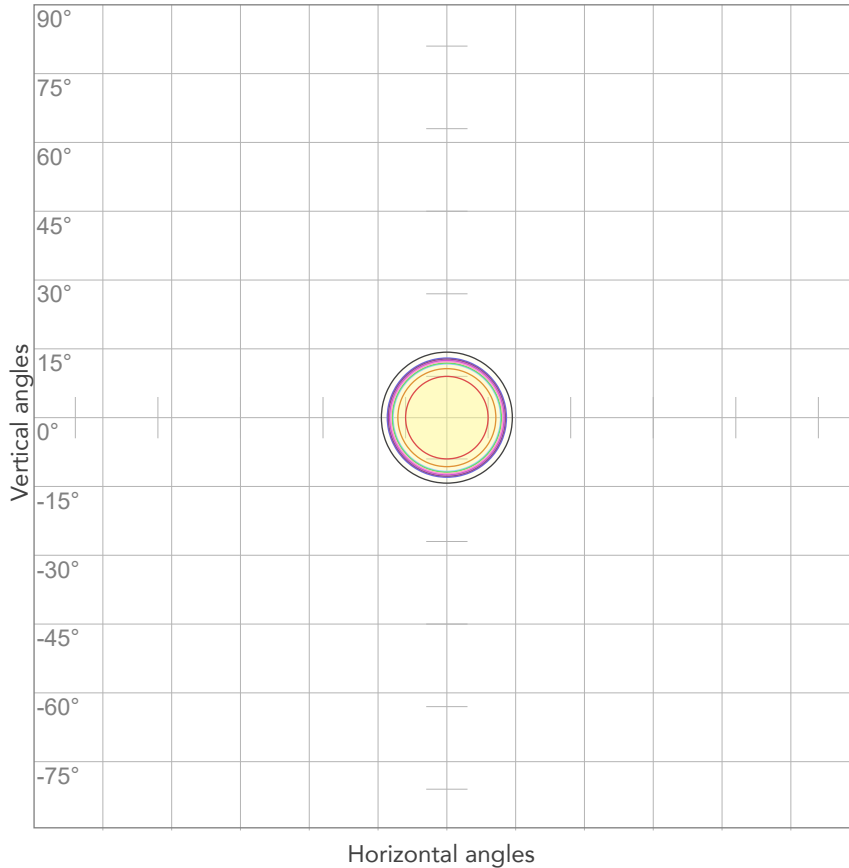

10%	9862 cd
20%	19724 cd
30%	29586 cd
40%	39448 cd
50%	49310 cd
60%	59172 cd
70%	69034 cd
80%	78896 cd

Conditions:

Number of c-planes: 2

Candela at center: 98620 cd

ISO LUX DIAGRAM

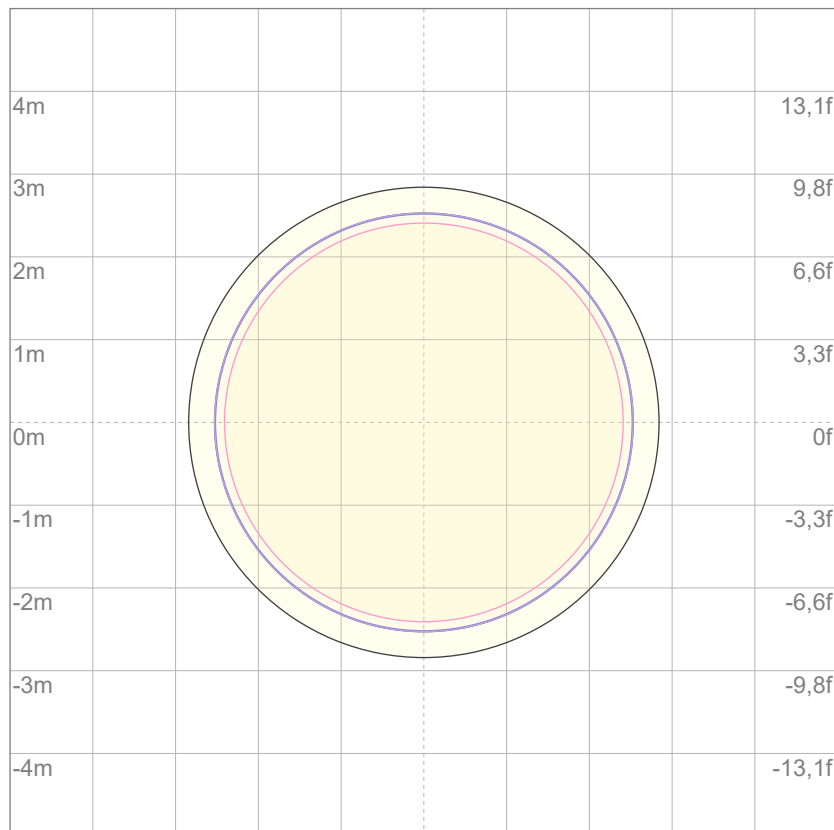

3%	29,6 lx
5%	49,3 lx
10%	98,6 lx
30%	296 lx
50%	493 lx

Conditions:

Number of c-planes: 2

Lux at center: 986 lx

Lux distribution on a surface when lamp is mounted at 10 meters from the surface.

Mounting height: 10 meters (33 feet)



Total lumen output:

15749 lm

Peak candela output:

106296 cd

Light quality:

CRI: 97,5

Color temperature:

4026 K

PRODUCT NAME:

ECLFWHPVW

MEASURAMENT CONDITIONS:

Beam angle:

PRL26

Target:

4000K

Operator:

Giuseppe della Peruta

Date and time:

07/01/2026 11:39:58

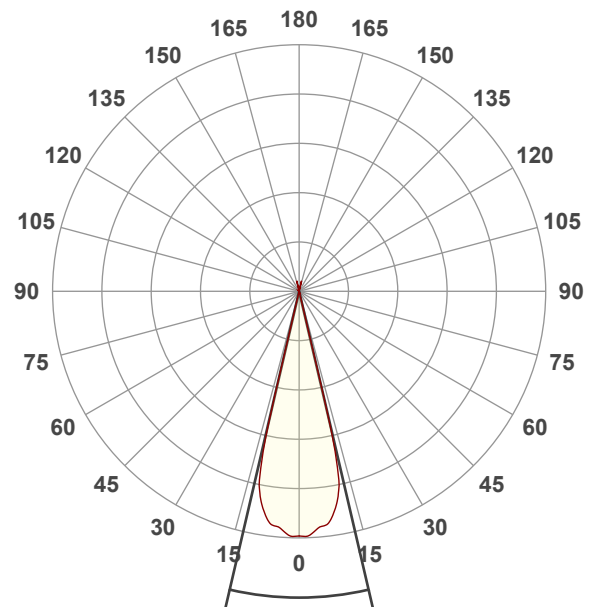

Beam angle 50%: 26,2°

Field angle 10%: 27,6°

Cut off angle 2.5%: 27,9°

Spectra

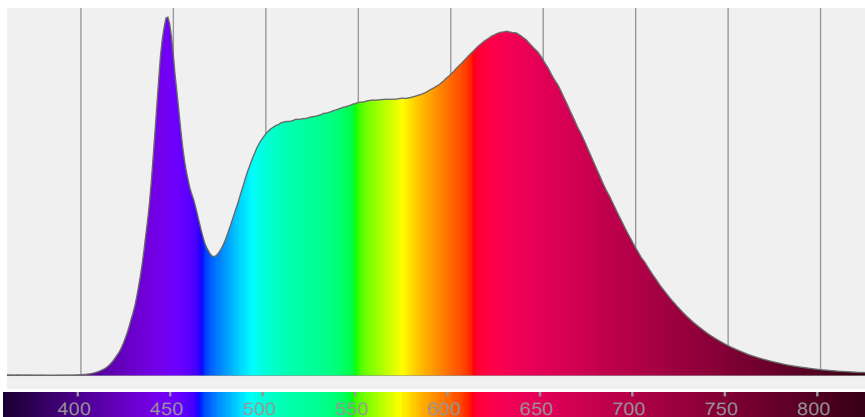

COLOR DETAILS

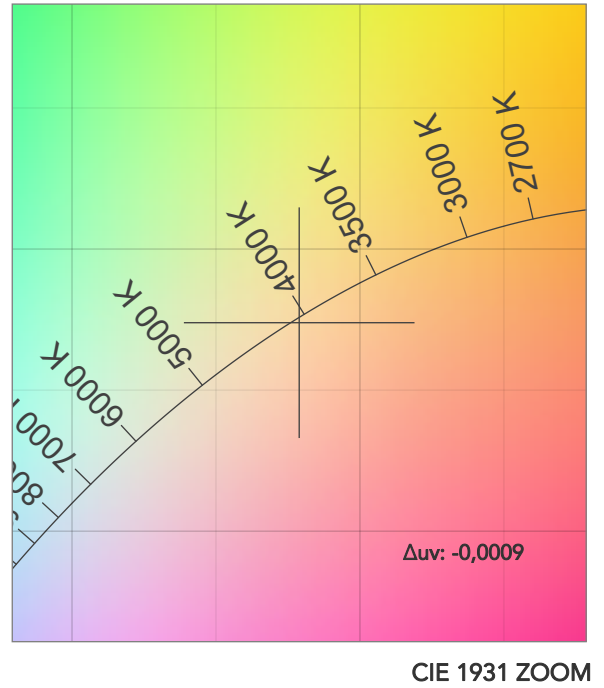
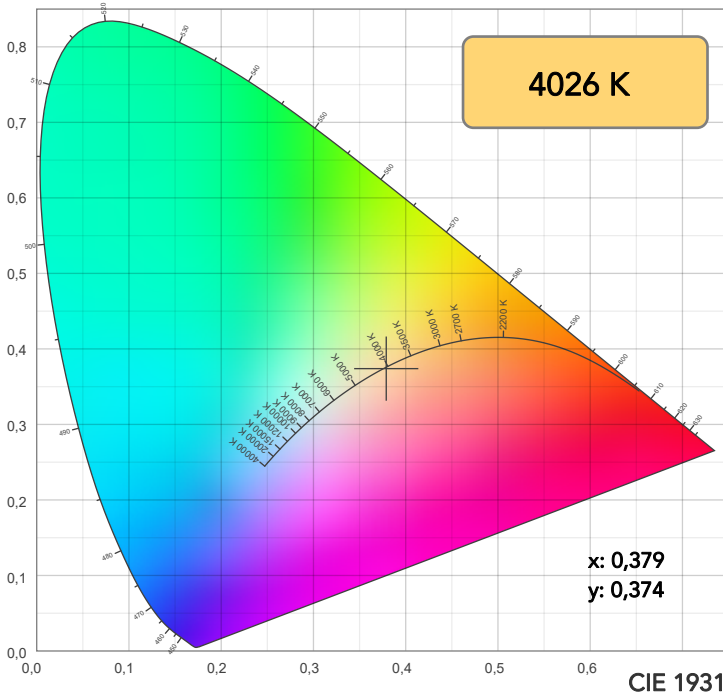

TM30: 96,1

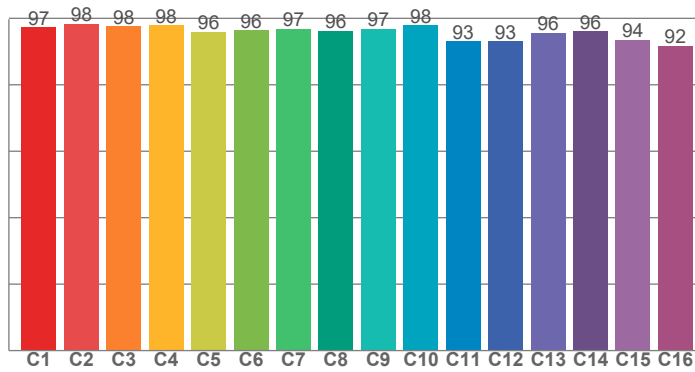

CRI: 97,5 (R1-R8)

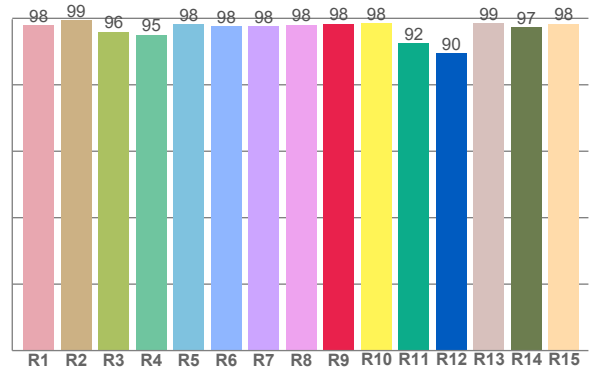

CRI R values, only R1-R8 are used to calculate final CRI value

R1	R2	R3	R4	R5	R6	R7	R8	R9	R10	R11	R12	R13	R14	R15
98,0	99,4	96,0	95,1	98,2	97,7	97,6	98,1	98,4	98,5	92,5	89,6	98,6	97,3	98,4

TM30 C values, 16 binned values out of total of 99 C values

C1	C2	C3	C4	C5	C6	C7	C8	C9	C10	C11	C12	C13	C14	C15	C16
97,3	98,3	97,6	98,0	95,9	96,4	96,9	96,3	96,8	98,0	93,1	93,1	95,6	96,1	93,6	91,7

CQS Q values

Q1	Q2	Q3	Q4	Q5	Q6	Q7	Q8	Q9	Q10	Q11	Q12	Q13	Q14	Q15
99,3	99,4	94,0	97,7	97,4	95,1	97,8	99,4	98,6	98,7	99,7	99,1	99,0	99,2	99,6

CQS: 97,6

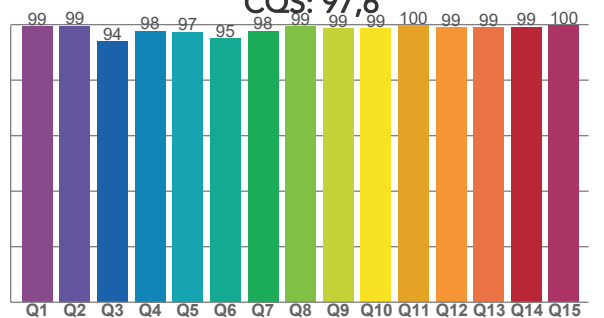

COLOR PARAMETERS

Color temperature	Color rendering index	Red component	Color fidelity	Color gamut	Color quality scale	Television lighting index	Color coordinate cie 1931	Color coordinate cie 1931	Color deviation from black body
CCT	CRI	CRI R9	TM30 Rf	TM30 Rg	CQS	TLCI	x	y	Δuv
4026 K	97,5	98,4	96,1	102,7	97,6	98	0,379	0,374	-0,0009

TM30 DETAILS

Rf 96,1
Fidelity index Rf

Rg 102,7
Gammut index

Hue Bin	R _f	Graphic shifts (%)	
		Chroma	Hue
1	97	0%	-1%
2	98	0%	-1%
3	98	0%	1%
4	98	0%	0%
5	96	0%	1%
6	96	2%	1%
7	97	2%	0%
8	96	1%	0%
9	97	1%	1%
10	98	0%	1%
11	93	2%	4%
12	93	3%	2%
13	96	3%	-1%
14	96	3%	0%
15	94	3%	-3%
16	92	3%	-5%

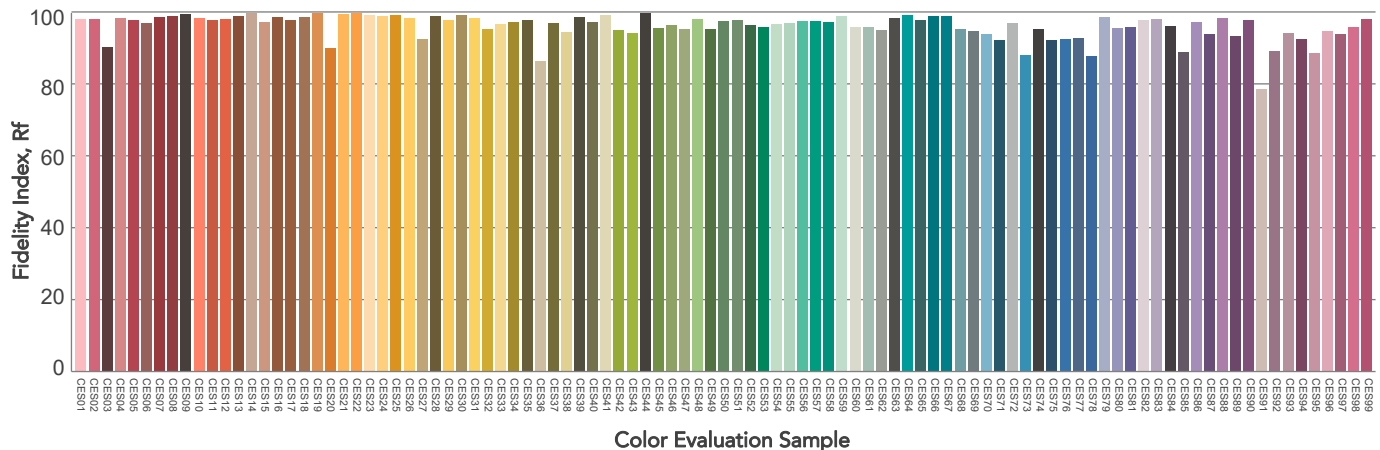
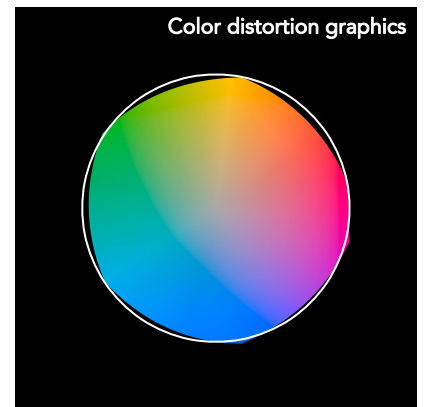
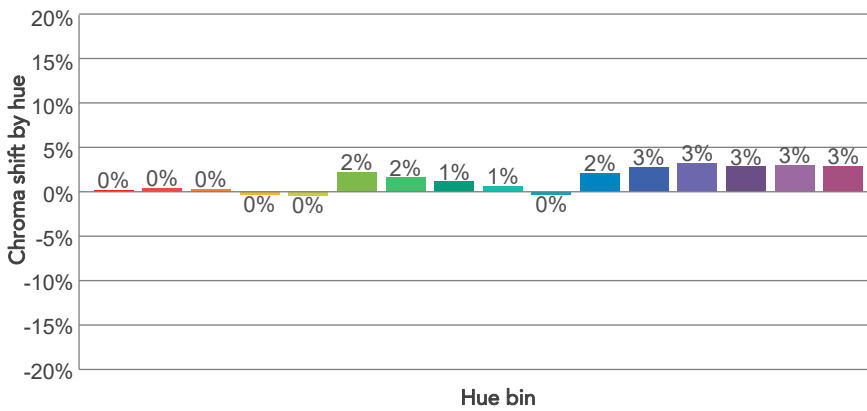
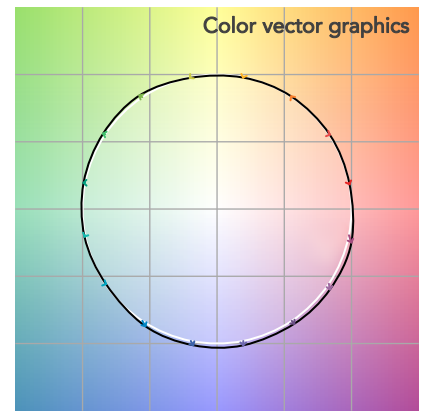
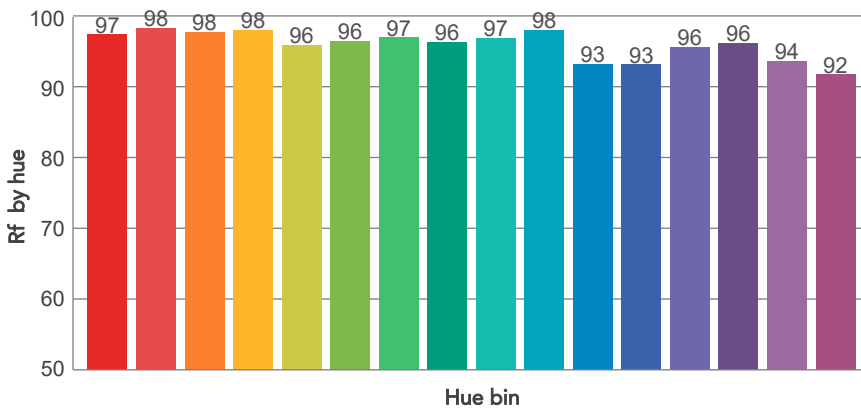
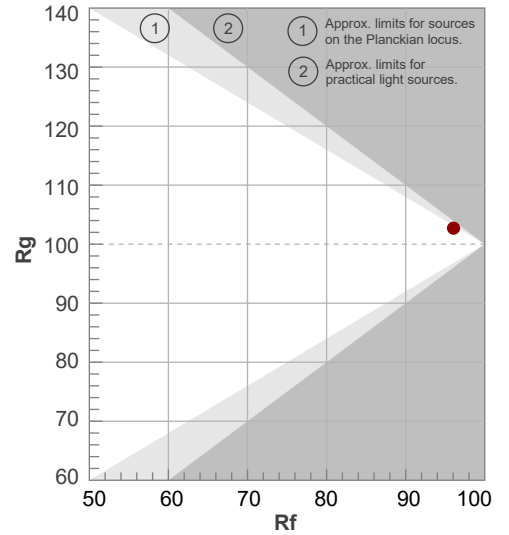

BEAM DETAILS



Beam angle 50%	Field angle 10%	Cut off angle 2,5%	Intensity ratio in 120° cone	Intensity ratio in 90° cone
26,2°	27,6°	27,9°	100,0%	100,0%

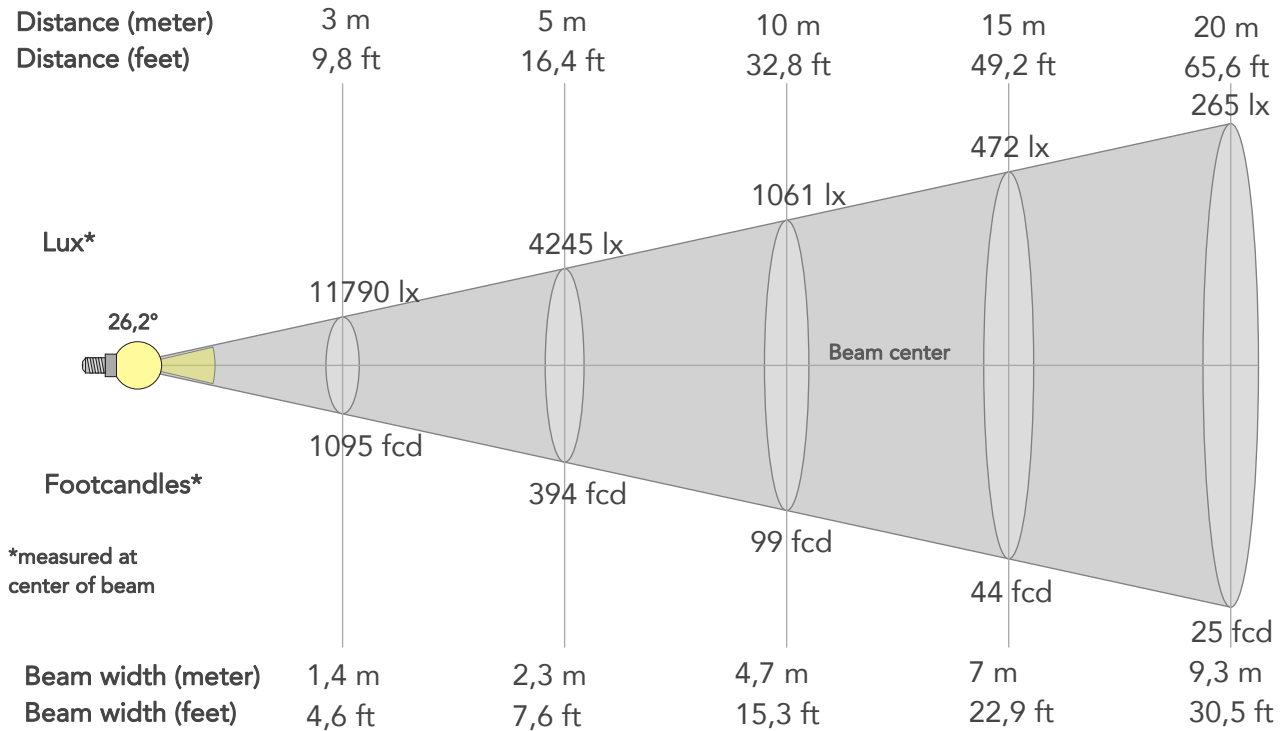

BEAM INTENSITIES AND WIDTHS

Distance	1m	2m	3m	4m	5m	7,5m	10m	15m	20m	25m	30m	40m	50m
Distance	3,3ft	6,6ft	9,8ft	13,1ft	16,4ft	24,6ft	32,8ft	49,2ft	65,6ft	82ft	98,4ft	131,2ft	164ft
Lux	106114lx	26528lx	11790lx	6632lx	4245lx	1886lx	1061lx	472lx	265lx	170lx	118lx	66lx	42lx
Footcand.	9858fcd	2465fcd	1095fcd	616fcd	394fcd	175fcd	99fcd	44fcd	25fcd	16fcd	11fcd	6fcd	4fcd
Beam wid.	0,5m	0,9m	1,4m	1,9m	2,3m	3,5m	4,7m	7m	9,3m	11,6m	14m	18,6m	23,3m
Beam wid.	1,5ft	3,1ft	4,6ft	6,1ft	7,6ft	11,5ft	15,3ft	22,9ft	30,5ft	38,2ft	45,8ft	61,1ft	76,4ft

LINEAR DISTRIBUTION DIAGRAM

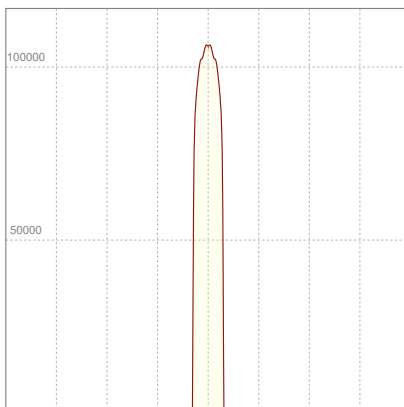

ELECTRICAL SPECIFICATIONS

Input voltage	Input current	Input power	Power FC	Efficiency
225V	2,00A	438,3W	0,97	36lm/W

ISO DIAGRAMS

ISO CANDELA DIAGRAM

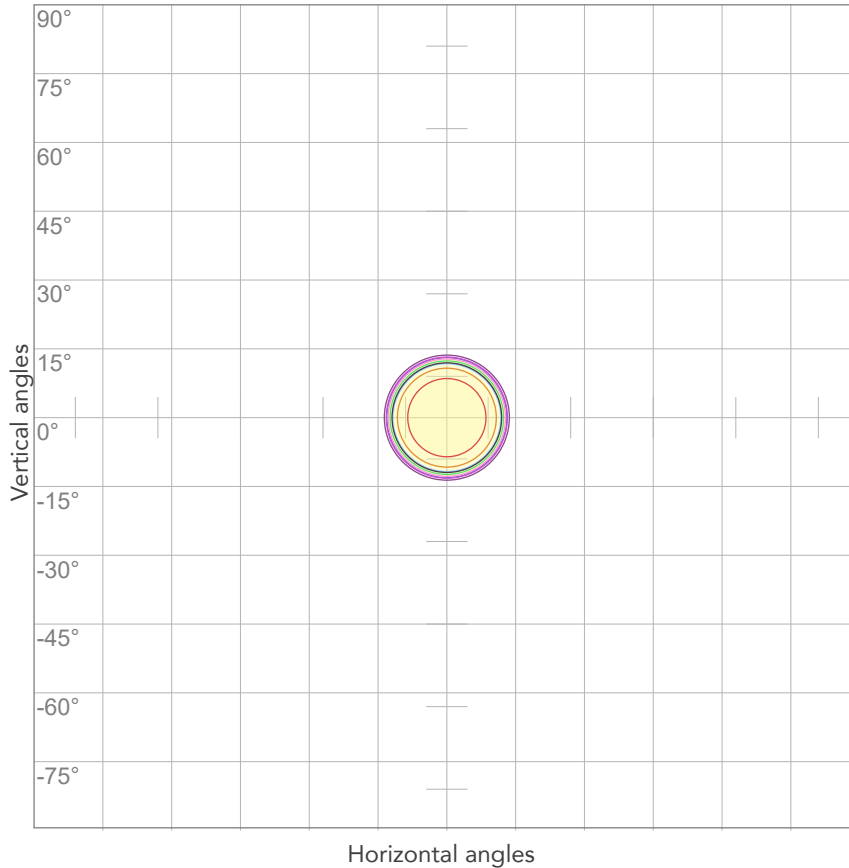

10%	10611 cd
20%	21223 cd
30%	31834 cd
40%	42446 cd
50%	53057 cd
60%	63668 cd
70%	74280 cd
80%	84891 cd

Conditions:

Number of c-planes: 2

Candela at center: 106114 cd

ISO LUX DIAGRAM

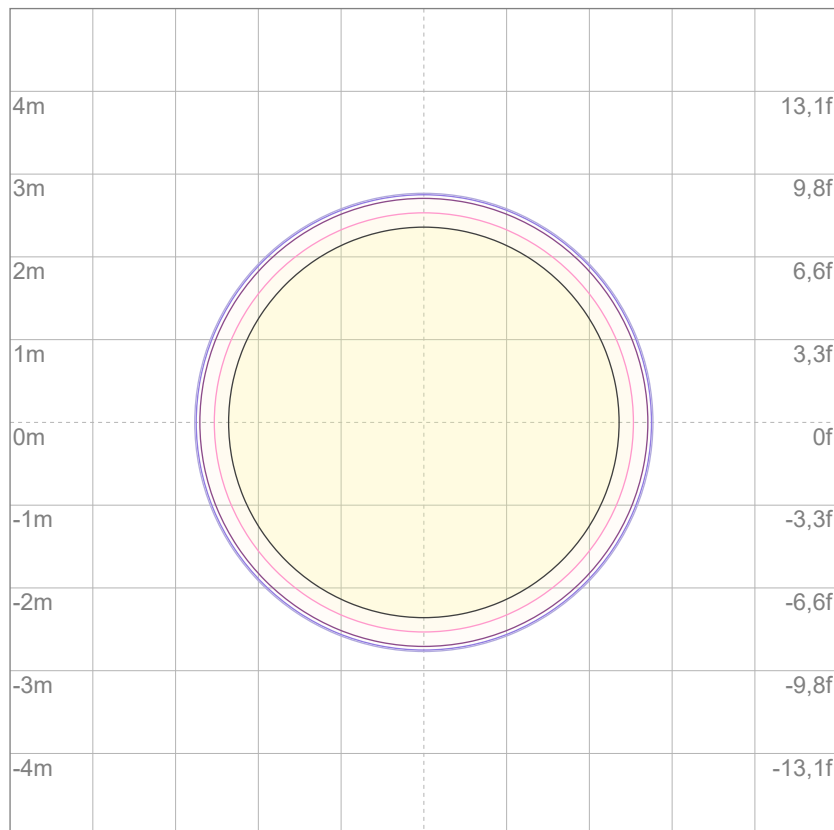

3%	31,8 lx
5%	53,1 lx
10%	106 lx
30%	318 lx
50%	531 lx

Conditions:

Number of c-planes: 2

Lux at center: 1061 lx

Lux distribution on a surface when lamp is mounted at 10 meters from the surface.

Mounting height: 10 meters (33 feet)



Total lumen output:

16662 lm

Peak candela output:

113415 cd

Light quality:

CRI: 97,4

Color temperature:

5597 K

PRODUCT NAME:

ECLFWHPVW

MEASUREMENT CONDITIONS:

Beam angle:

PRL26

Target:

5600K

Operator:

Giuseppe della Peruta

Date and time:

07/01/2026 11:44:33

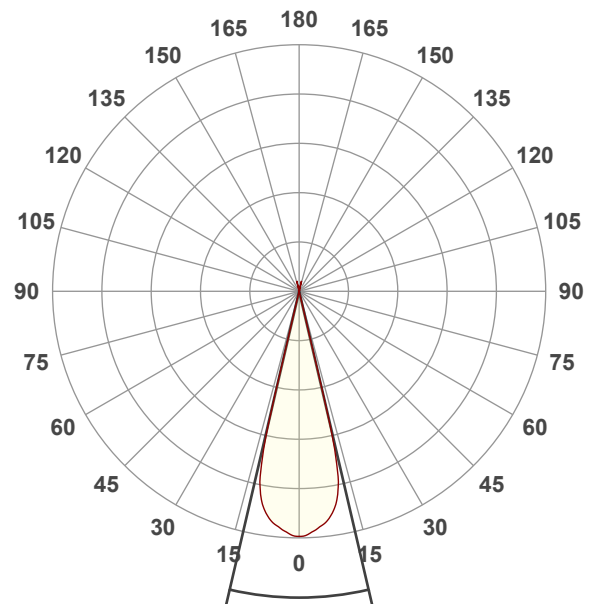

Beam angle 50%: 26,2°

Field angle 10%: 27,7°

Cut off angle 2.5%: 27,9°

Spectra

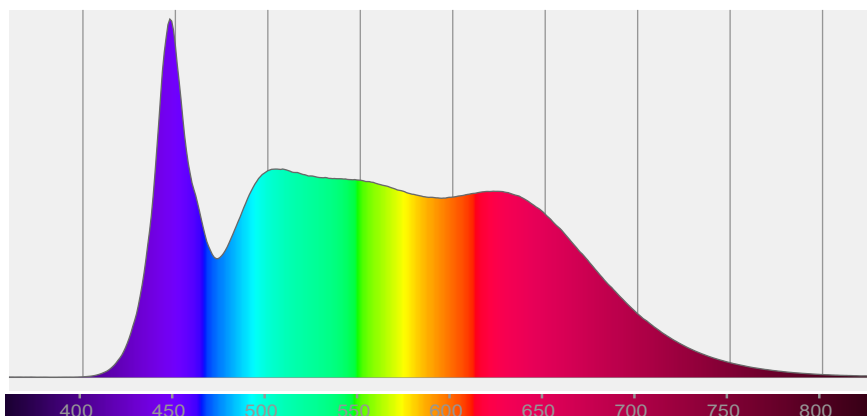

COLOR DETAILS

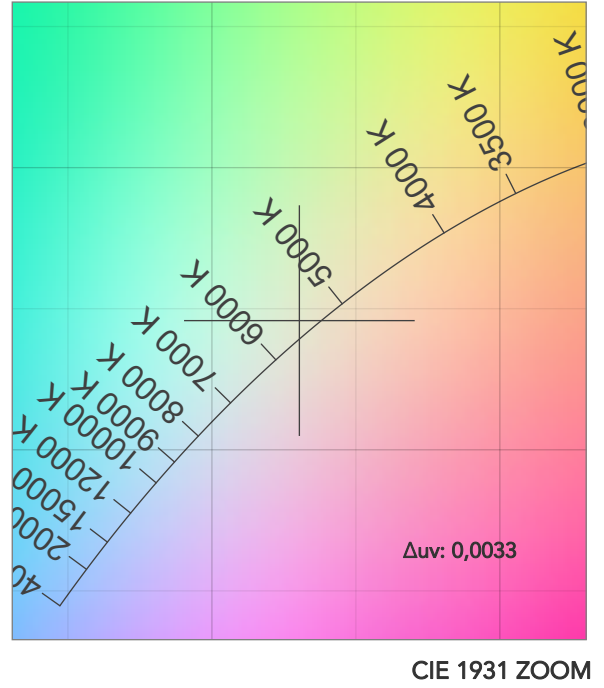
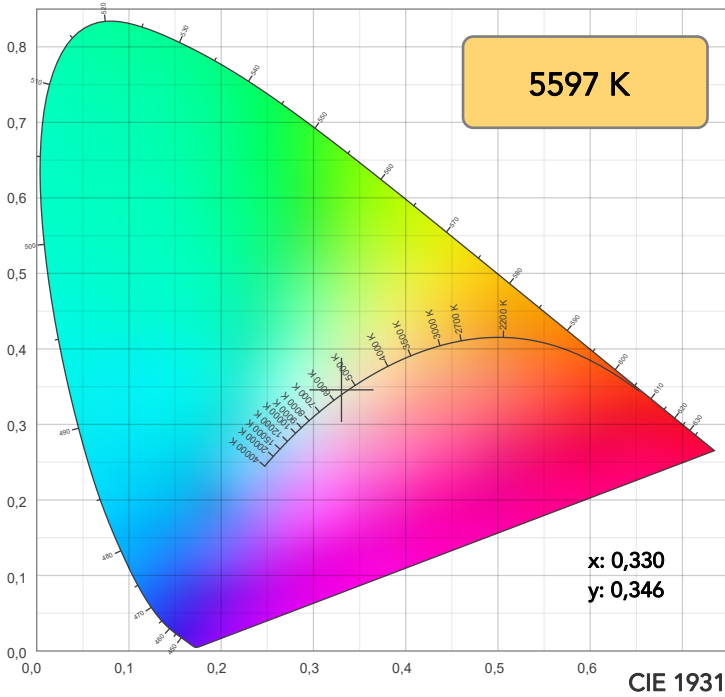

TM30: 95,7

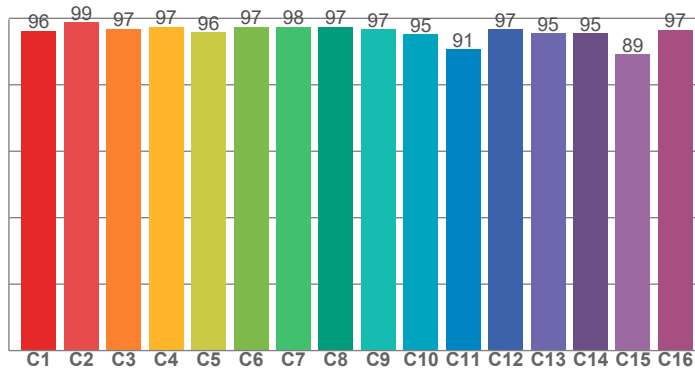

CRI: 97,4 (R1-R8)

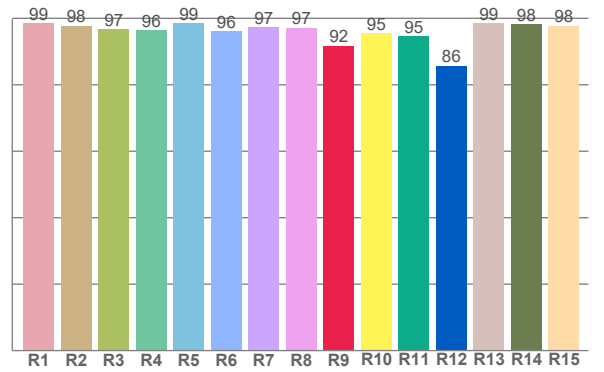

CRI R values, only R1-R8 are used to calculate final CRI value

R1	R2	R3	R4	R5	R6	R7	R8	R9	R10	R11	R12	R13	R14	R15
98,6	97,8	96,6	96,5	98,6	96,1	97,4	97,2	91,8	95,5	94,5	85,7	98,5	98,2	97,8

TM30 C values, 16 binned values out of total of 99 C values

C1	C2	C3	C4	C5	C6	C7	C8	C9	C10	C11	C12	C13	C14	C15	C16
96,2	98,8	96,8	97,4	95,8	97,5	97,5	97,5	96,8	95,2	90,6	96,7	95,4	95,4	89,2	96,6

CQS Q values

Q1	Q2	Q3	Q4	Q5	Q6	Q7	Q8	Q9	Q10	Q11	Q12	Q13	Q14	Q15
97,9	99,1	92,5	95,3	98,2	96,3	97,8	99,6	99,1	97,9	98,8	98,9	99,1	97,6	97,7

CQS: 97,1

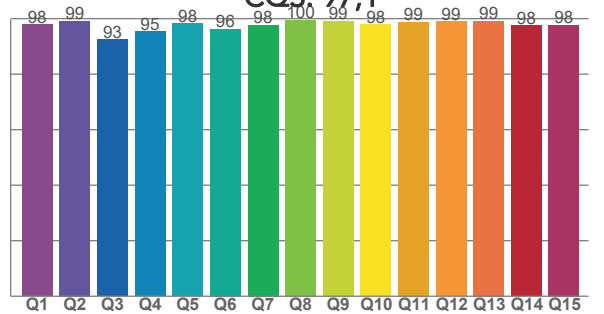

COLOR PARAMETERS

Color temperature	Color rendering index	Red component	Color fidelity	Color gamut	Color quality scale	Television lighting index	Color coordinate cie 1931	Color coordinate cie 1931	Color deviation from black body
CCT	CRI	CRI R9	TM30 Rf	TM30 Rg	CQS	TLCI	x	y	Δuv
5597 K	97,4	91,8	95,7	101,5	97,1	99	0,330	0,346	0,0033

TM30 DETAILS

Rf 95,7
Fidelity index Rf

Rg 101,5
Gammut index

Hue Bin	R _f	Graphic shifts (%)	
		Chroma	Hue
1	96	-1%	-1%
2	99	-1%	0%
3	97	0%	1%
4	97	-1%	0%
5	96	-1%	1%
6	97	1%	1%
7	98	1%	0%
8	97	0%	0%
9	97	-1%	2%
10	95	0%	3%
11	91	2%	6%
12	97	2%	1%
13	95	4%	-1%
14	95	2%	-1%
15	89	7%	-7%
16	97	1%	-2%

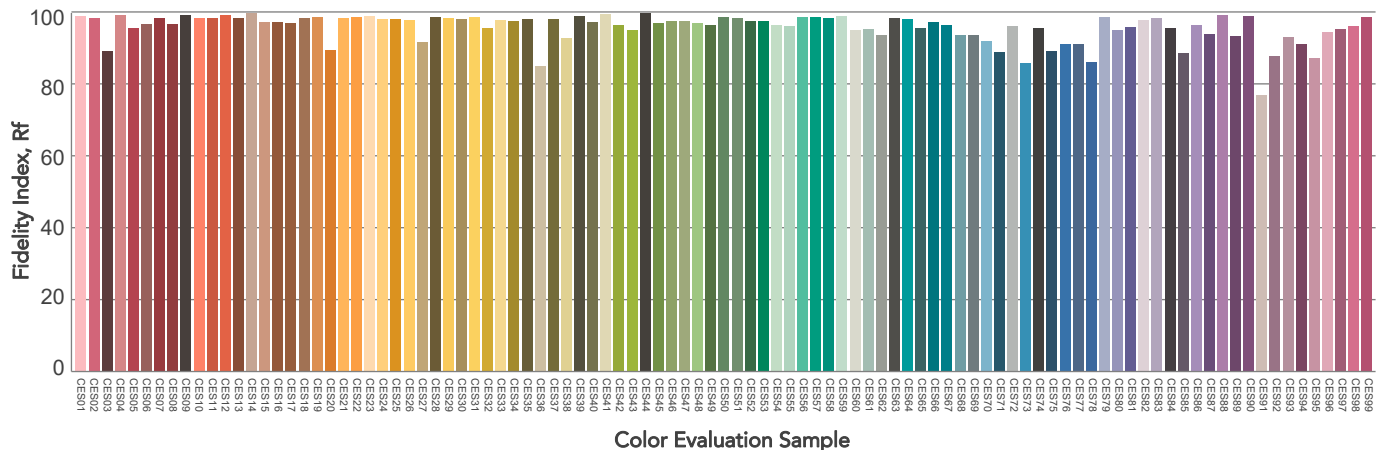
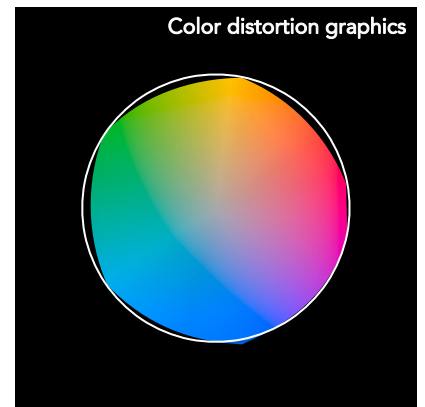
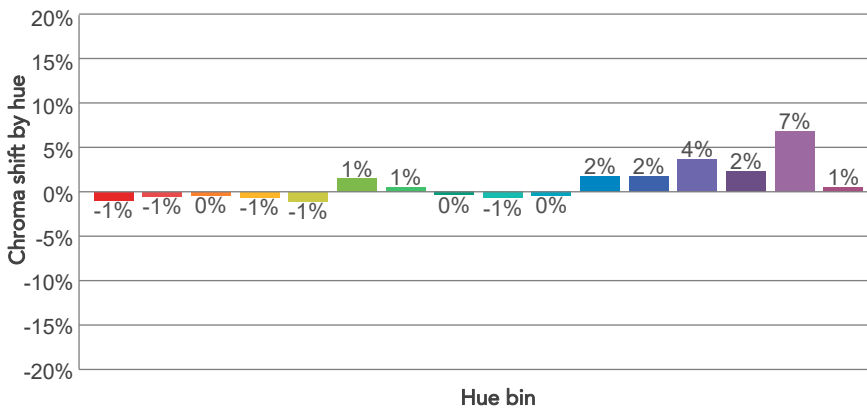
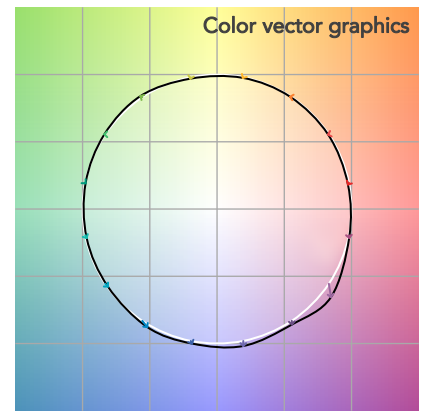
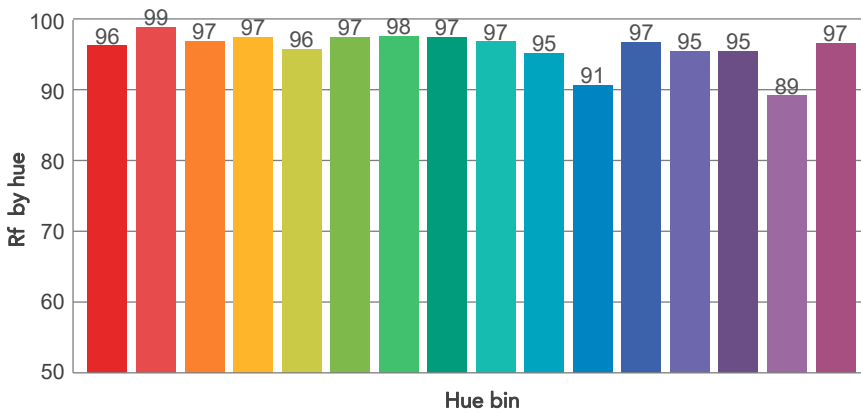
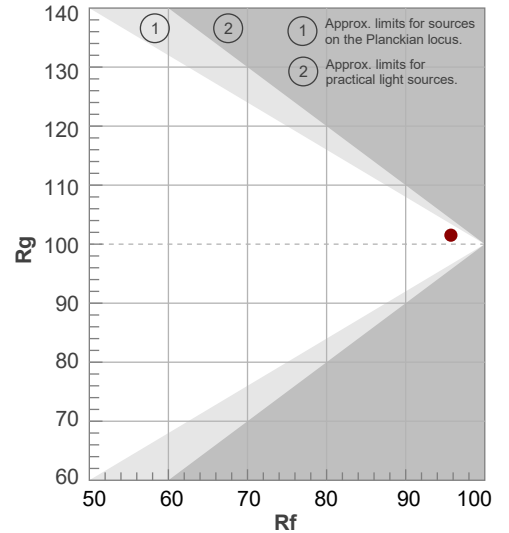

BEAM DETAILS



Beam angle 50%	Field angle 10%	Cut off angle 2,5%	Intensity ratio in 120° cone	Intensity ratio in 90° cone
26,2°	27,7°	27,9°	100,0%	100,0%

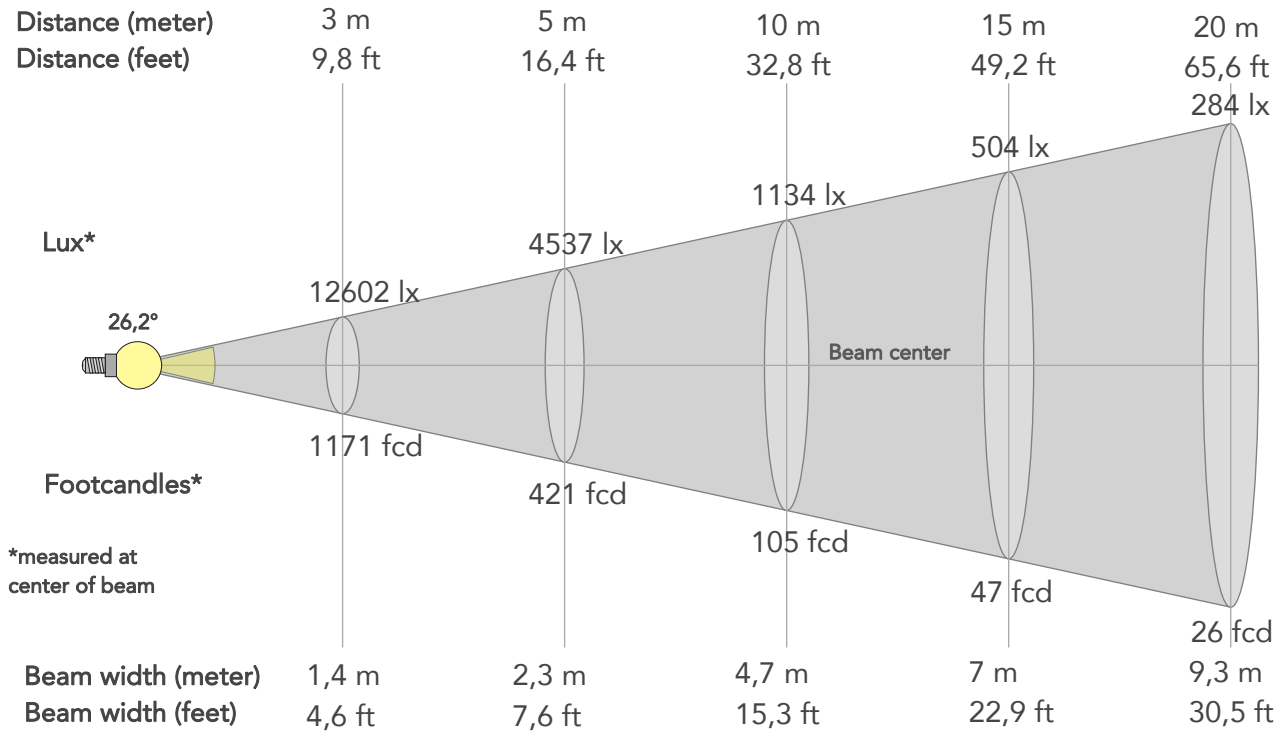

BEAM INTENSITIES AND WIDTHS

Distance	1m	2m	3m	4m	5m	7,5m	10m	15m	20m	25m	30m	40m	50m
Distance	3,3ft	6,6ft	9,8ft	13,1ft	16,4ft	24,6ft	32,8ft	49,2ft	65,6ft	82ft	98,4ft	131,2ft	164ft
Lux	113415lx	28354lx	12602lx	7088lx	4537lx	2016lx	1134lx	504lx	284lx	181lx	126lx	71lx	45lx
Footcand.	10537fcd	2634fcd	1171fcd	659fcd	421fcd	187fcd	105fcd	47fcd	26fcd	17fcd	12fcd	7fcd	4fcd
Beam wid.	0,5m	0,9m	1,4m	1,9m	2,3m	3,5m	4,7m	7m	9,3m	11,6m	14m	18,6m	23,3m
Beam wid.	1,5ft	3,1ft	4,6ft	6,1ft	7,6ft	11,5ft	15,3ft	22,9ft	30,5ft	38,2ft	45,8ft	61,1ft	76,4ft

LINEAR DISTRIBUTION DIAGRAM

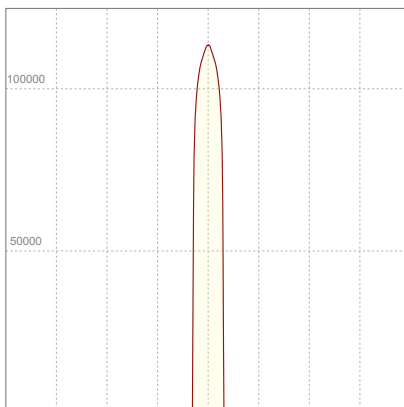

ELECTRICAL SPECIFICATIONS

Input voltage	Input current	Input power	Power FC	Efficiency
225V	1,97A	431,9W	0,97	39lm/W

ISO DIAGRAMS

ISO CANDELA DIAGRAM

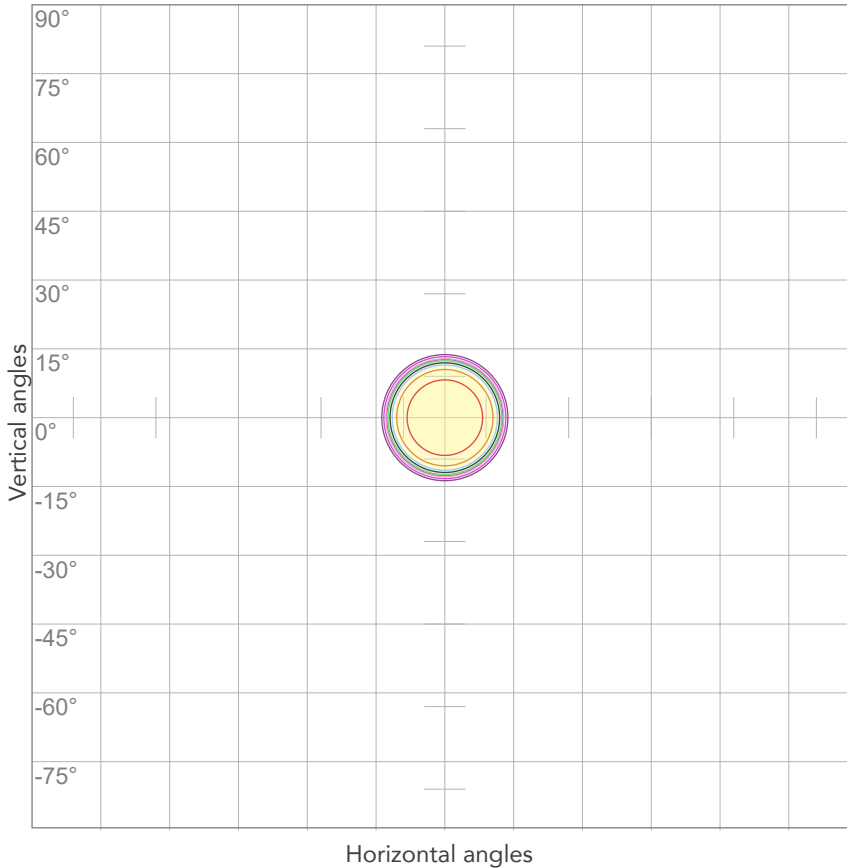

10%	11342 cd
20%	22683 cd
30%	34025 cd
40%	45366 cd
50%	56708 cd
60%	68049 cd
70%	79391 cd
80%	90732 cd

Conditions:

Number of c-planes: 2

Candela at center: 113415 cd

ISO LUX DIAGRAM

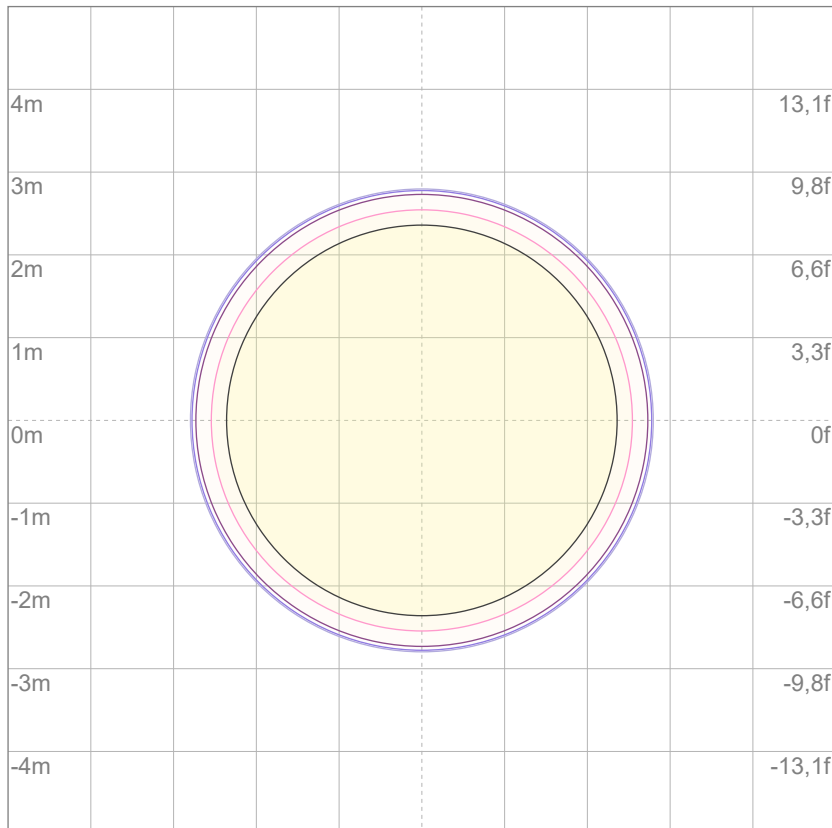

Mounting height: 10 meters (33 feet)

3%	34,0 lx
5%	56,7 lx
10%	113 lx
30%	340 lx
50%	567 lx

Conditions:

Number of c-planes: 2

Lux at center: 1134 lx

Lux distribution on a surface when lamp is mounted at 10 meters from the surface.



Total lumen output:

16505 lm

Peak candela output:

112634 cd

Light quality:

CRI: 96,7

Color temperature:

6008 K

PRODUCT NAME:

ECLFWHPVW

MEASURAMENT CONDITIONS:

Beam angle:

PRL26

Target:

6000K

Operator:

Giuseppe della Peruta

Date and time:

07/01/2026 11:50:38

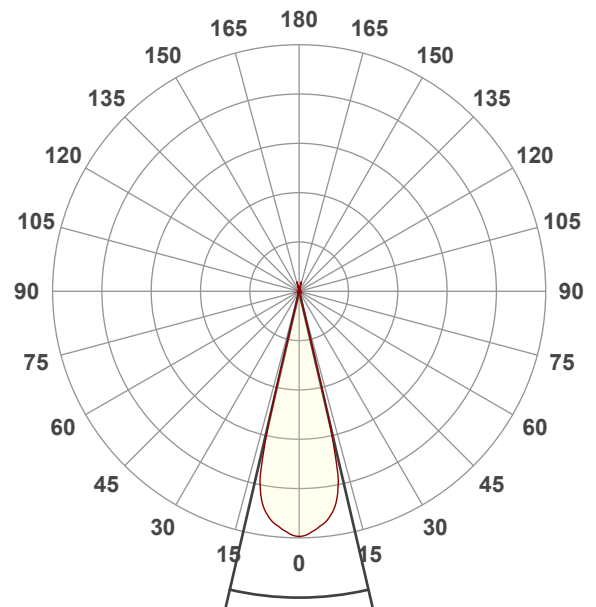

Beam angle 50%: 26,2°

Field angle 10%: 27,7°

Cut off angle 2.5%: 28°

Spectra

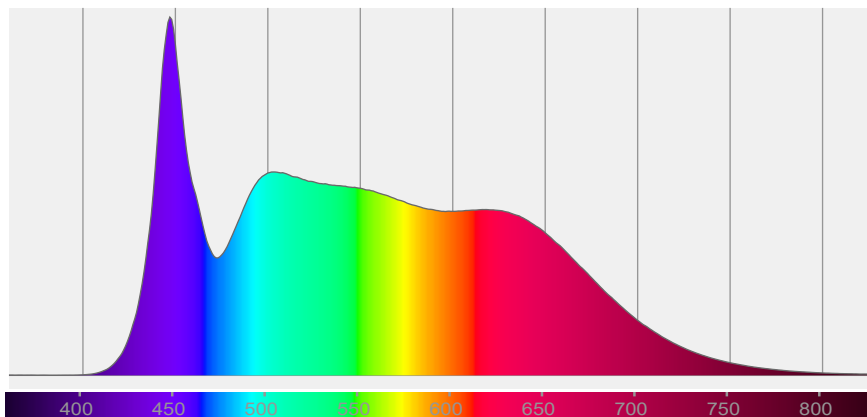

COLOR DETAILS

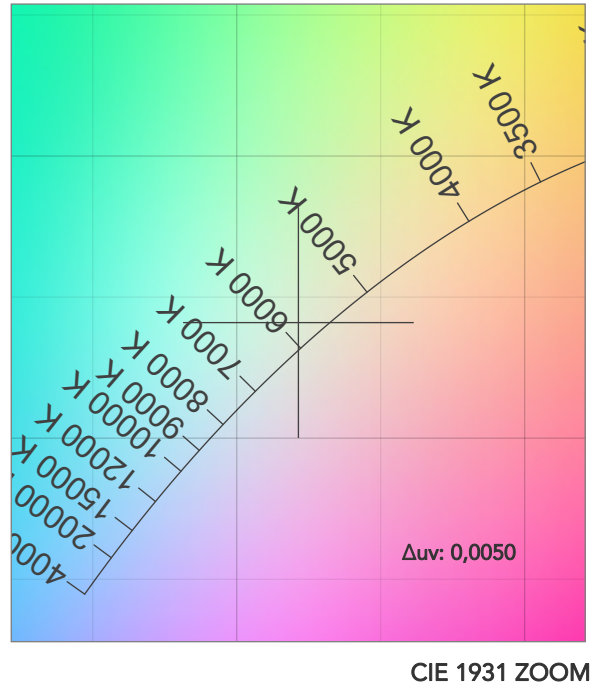
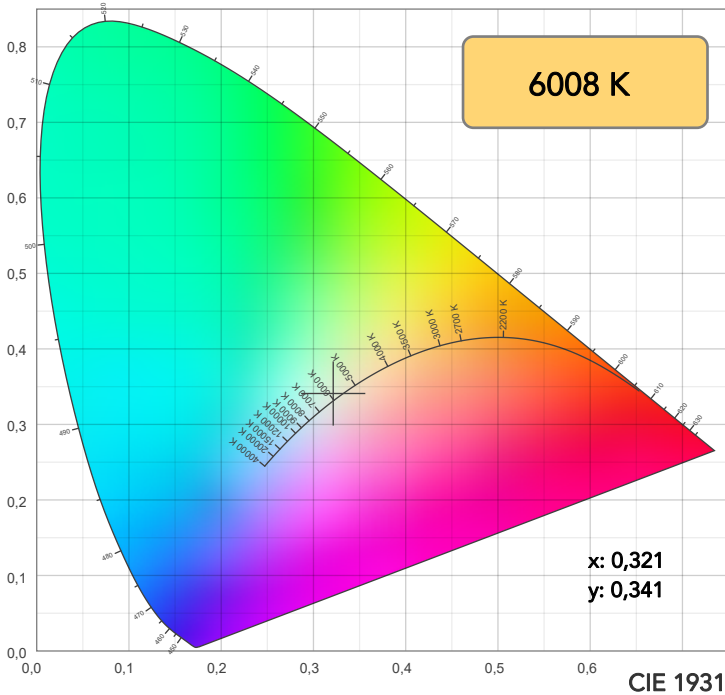

TM30: 95,3

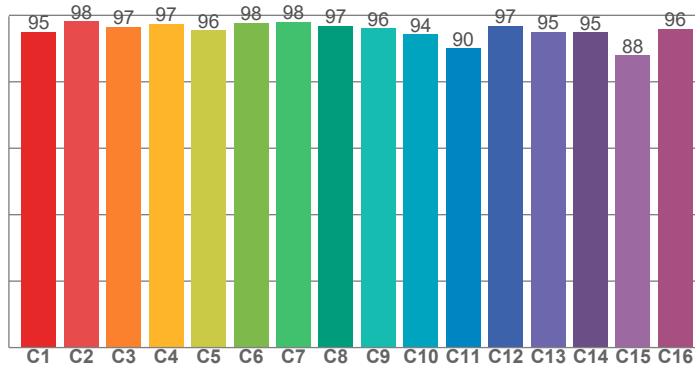

CRI: 96,7 (R1-R8)

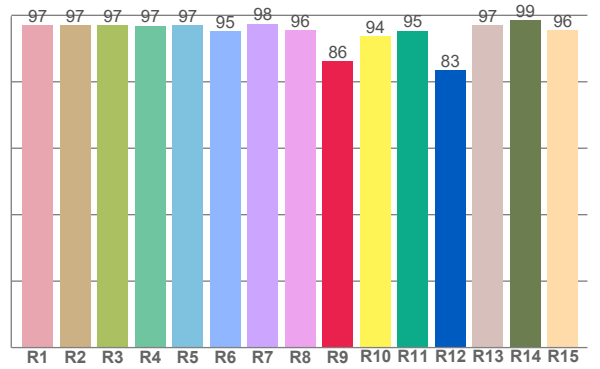

CRI R values, only R1-R8 are used to calculate final CRI value

R1	R2	R3	R4	R5	R6	R7	R8	R9	R10	R11	R12	R13	R14	R15
97,0	96,9	96,9	96,9	97,1	95,3	97,5	95,6	86,2	93,8	95,4	83,4	96,9	98,6	95,6

TM30 C values, 16 binned values out of total of 99 C values

C1	C2	C3	C4	C5	C6	C7	C8	C9	C10	C11	C12	C13	C14	C15	C16
95,1	98,2	96,5	97,4	95,6	97,8	98,1	96,8	96,1	94,3	90,1	96,9	95,0	94,9	88,0	96,0

CQS Q values

Q1	Q2	Q3	Q4	Q5	Q6	Q7	Q8	Q9	Q10	Q11	Q12	Q13	Q14	Q15
96,8	99,4	92,7	94,8	97,9	96,8	97,5	99,1	99,7	98,3	98,9	98,6	98,6	96,2	96,5

CQS: 96,9

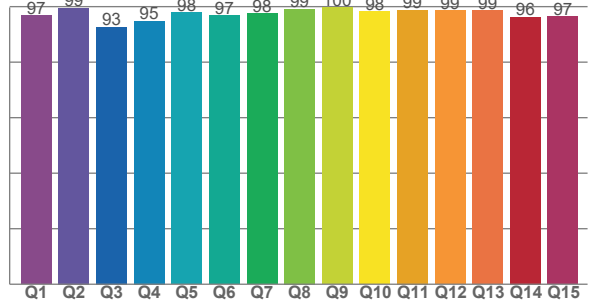

COLOR PARAMETERS

Color temperature	Color rendering index	Red component	Color fidelity	Color gamut	Color quality scale	Television lighting index	Color coordinate cie 1931	Color coordinate cie 1931	Color deviation from black body
CCT	CRI	CRI R9	TM30 Rf	TM30 Rg	CQS	TLCI	x	y	Δuv
6008 K	96,7	86,2	95,3	100,7	96,9	99	0,321	0,341	0,0050

TM30 DETAILS

Rf 95,3
Fidelity index Rf

Rg 100,7
Gammut index

Hue Bin	R _f	Graphic shifts (%)	
		Chroma	Hue
1	95	-2%	-1%
2	98	-1%	0%
3	97	-1%	1%
4	97	-1%	0%
5	96	-2%	0%
6	98	0%	0%
7	98	1%	0%
8	97	-1%	0%
9	96	-1%	3%
10	94	-1%	3%
11	90	2%	6%
12	97	2%	1%
13	95	4%	-1%
14	95	2%	-2%
15	88	7%	-9%
16	96	0%	-2%

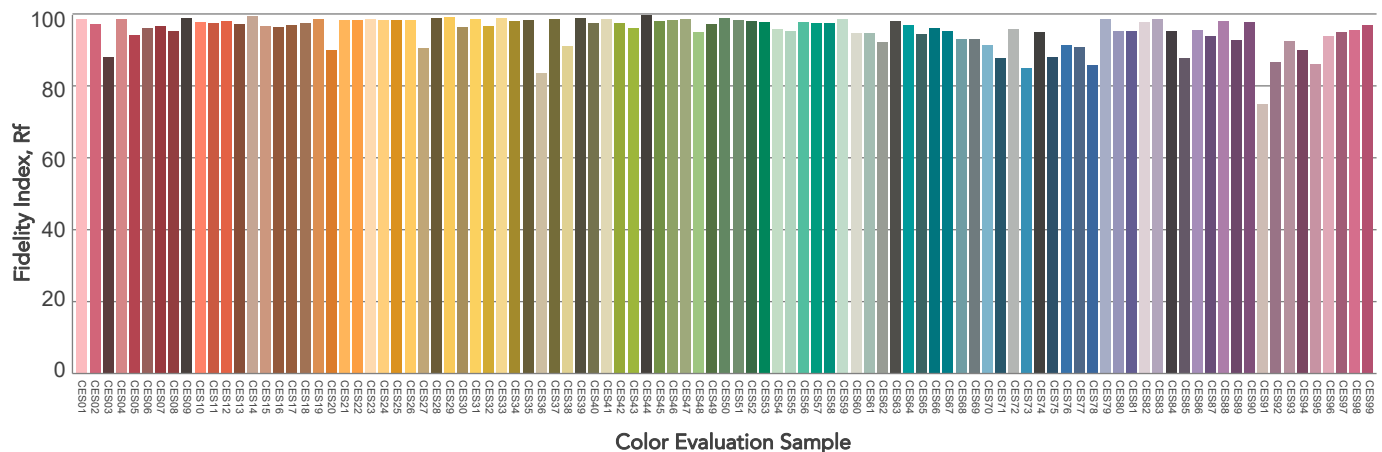
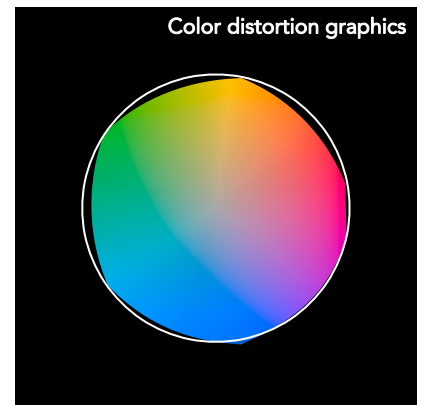
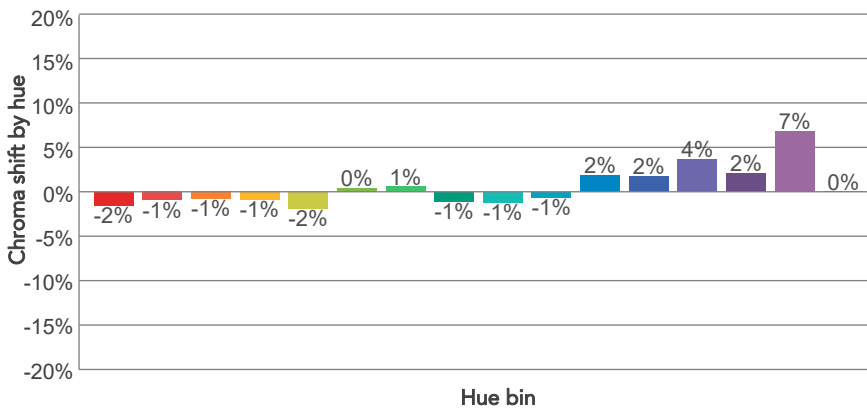
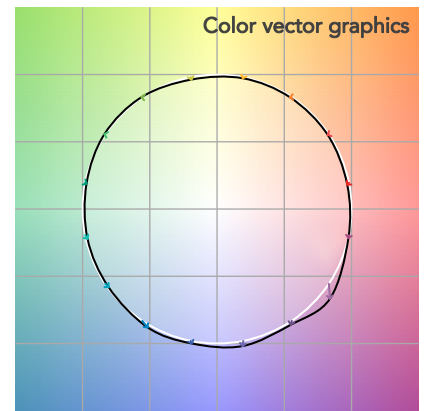
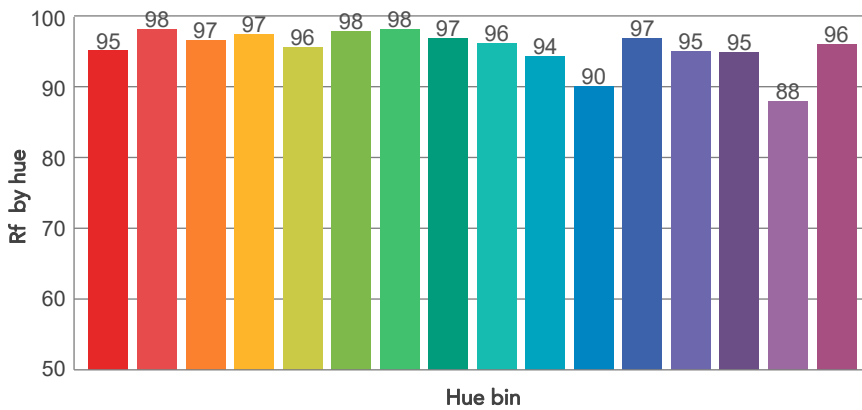
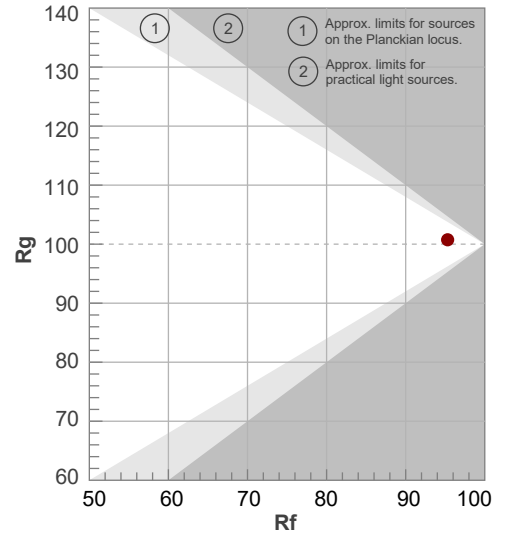

BEAM DETAILS



Beam angle 50%	Field angle 10%	Cut off angle 2,5%	Intensity ratio in 120° cone	Intensity ratio in 90° cone
26,2°	27,7°	28°	100,0%	100,0%

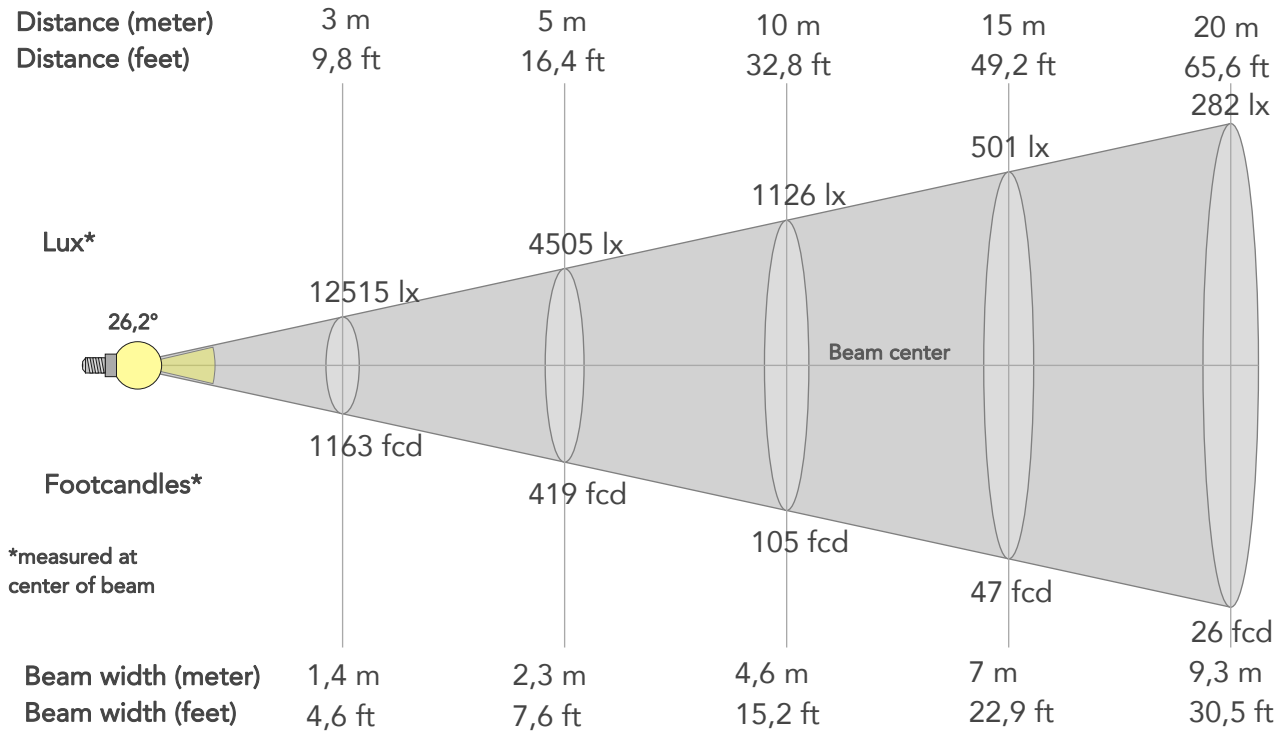

BEAM INTENSITIES AND WIDTHS

Distance	1m	2m	3m	4m	5m	7,5m	10m	15m	20m	25m	30m	40m	50m
Distance	3,3ft	6,6ft	9,8ft	13,1ft	16,4ft	24,6ft	32,8ft	49,2ft	65,6ft	82ft	98,4ft	131,2ft	164ft
Lux	112634lx	28159lx	12515lx	7040lx	4505lx	2002lx	1126lx	501lx	282lx	180lx	125lx	70lx	45lx
Footcand.	10464fcd	2616fcd	1163fcd	654fcd	419fcd	186fcd	105fcd	47fcd	26fcd	17fcd	12fcd	7fcd	4fcd
Beam wid.	0,5m	0,9m	1,4m	1,9m	2,3m	3,5m	4,6m	7m	9,3m	11,6m	13,9m	18,6m	23,2m
Beam wid.	1,5ft	3,1ft	4,6ft	6,1ft	7,6ft	11,4ft	15,2ft	22,9ft	30,5ft	38,1ft	45,7ft	61ft	76,2ft

LINEAR DISTRIBUTION DIAGRAM

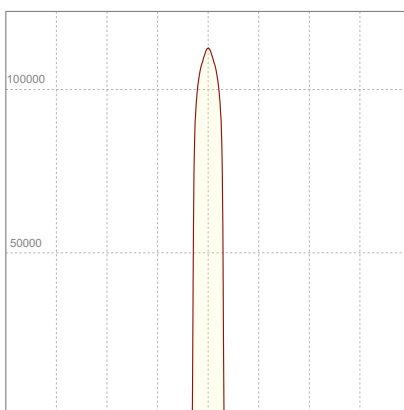

ELECTRICAL SPECIFICATIONS

Input voltage	Input current	Input power	Power FC	Efficiency
225V	1,93A	420,9W	0,97	39lm/W

ISO DIAGRAMS

ISO CANDELA DIAGRAM

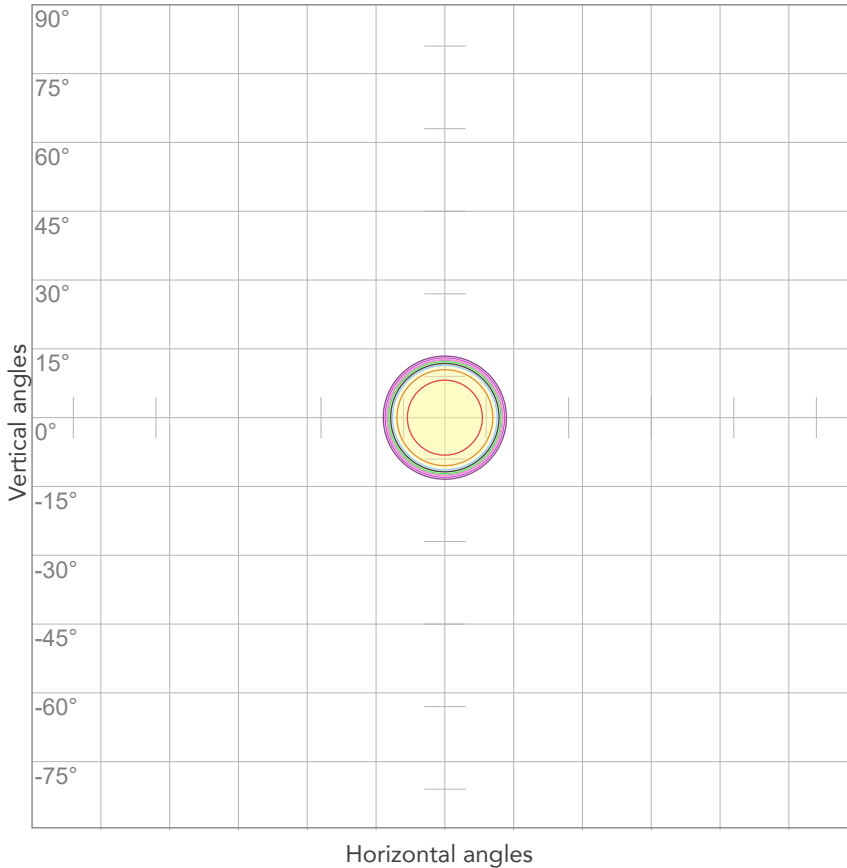

10%	11263 cd
20%	22527 cd
30%	33790 cd
40%	45054 cd
50%	56317 cd
60%	67581 cd
70%	78844 cd
80%	90107 cd

Conditions:

Number of c-planes: 2

Candela at center: 112634 cd

ISO LUX DIAGRAM

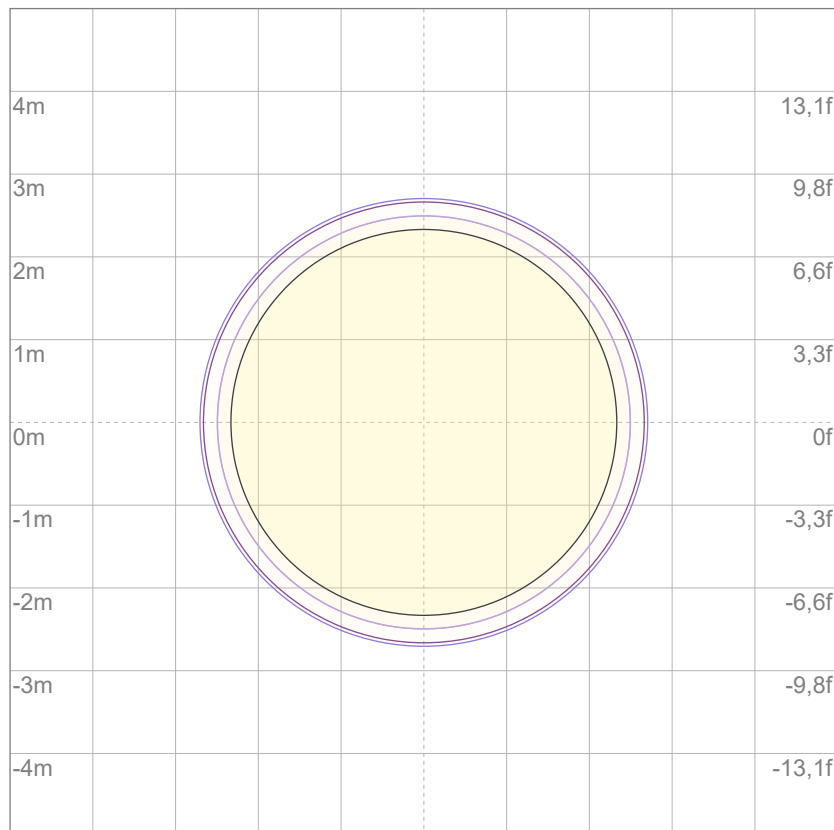

3%	33,8 lx
5%	56,3 lx
10%	113 lx
30%	338 lx
50%	563 lx

Conditions:

Number of c-planes: 2

Lux at center: 1126 lx

Lux distribution on a surface when lamp is mounted at 10 meters from the surface.

Mounting height: 10 meters (33 feet)