



# Photometric Test Report



## **EclProfile FWHPVW**

450W high quality VariableWhite LED  
ellipsoidal, compatible with PRL and PRLZ lenses

(ECLPRL19BK)

## CONTENTS

Table of contents	2
Testing process	3
<b>PRL 19° Lens:</b>	
Full On	4
Warm White	9
Cold White	14
2800K	19
3200K	24
4000K	29
5600K	34
6000K	39

## TESTING PROCESS

Prolights has its own optical testing laboratory in order to provide accurate photometric reports for its lighting products. The testing laboratory contains certain variety of precise lighting measurement systems that ensure an optimal reading of all the characteristic parameters of the lighting devices. All measurements are made at a controlled room temperature of 20°C without any external light sources. This photometric report is obtained through the data measured by a high precision measurement system and analyzed by a dedicate software.

### **Prolights measurement instrument**

Prolights measurement instrument is a complete measurement system for any light source. It's equipped with two-axis goniometer, that enables to measure the full 3D distribution field of the light source. This instrument measures the light intensity, the beam angle and the most significative colors parameters, like color temperature, spectral distribution, CRI, CQS, TM-30 with a very high accuracy rate.

**Please Note:** All measurements are made with light source at operating temperature. Before starting the measurement, the instrument analyzes the process of the light source during the heating phase. The measuring process of all the parameters begins only when the light emission is stable, that is with a variation of less than 0.5% in a 15 minutes time frame.

### **Prolights measurement software**

The software provides user friendly interface for the operator who does the measurements, and it also analyzes and processes all the collected data by the instrument. With this software it is possible to see the measured data in real-time and it is possible to examine all the measured data and graphics afterwards as well. All information is collected in a specific Prolights template, and the software creates also IES and LDT files, which are widely used to transfer the photometric data, and to develop lighting system.

Additionally, the fixtures are rechecked using various hand-held instruments like Sekonic C-700 and Gossen Mavospec Base, this is done to ensure, that the data in the photometric report are as accurate as possible.



Total lumen output:

12439 lm

Peak candela output:

153866 cd

Light quality:

CRI: 98,1

Color temperature:

4184 K

PRODUCT NAME:

ECLFWHPVW

MEASURAMENT CONDITIONS:

Beam angle:

PRL19

Target:

Full On

Operator:

Giuseppe della Peruta

Date and time:

07/01/2026 12:38:38

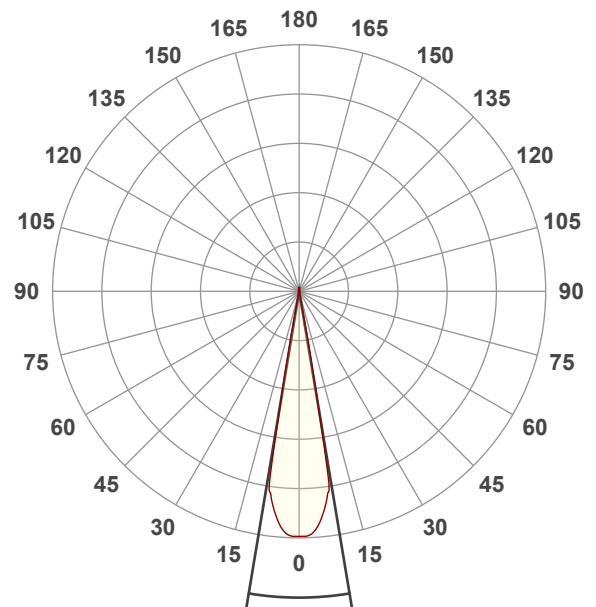

Beam angle 50%: 18,9°

Field angle 10%: 21,2°

Cut off angle 2.5%: 21,8°

Spectra

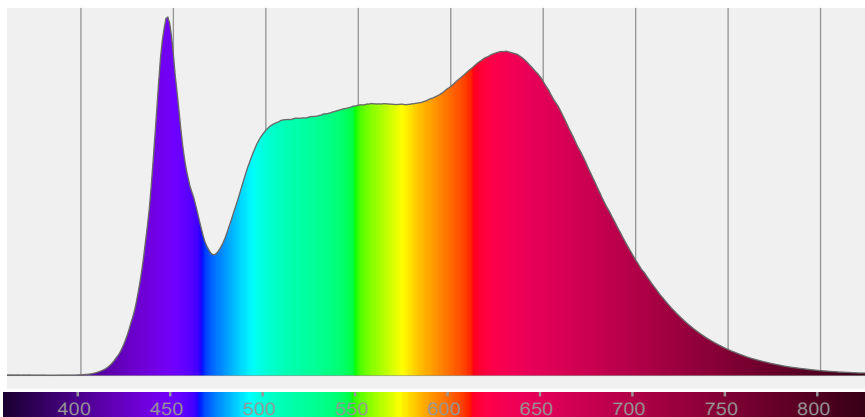

# COLOR DETAILS

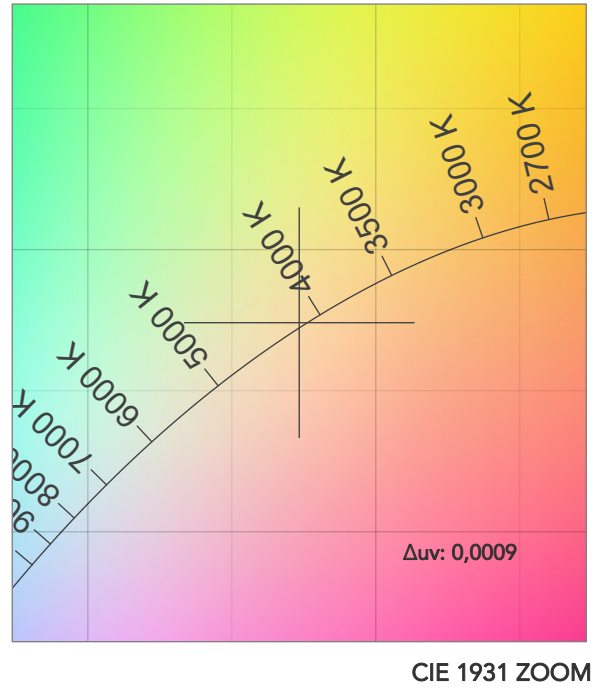
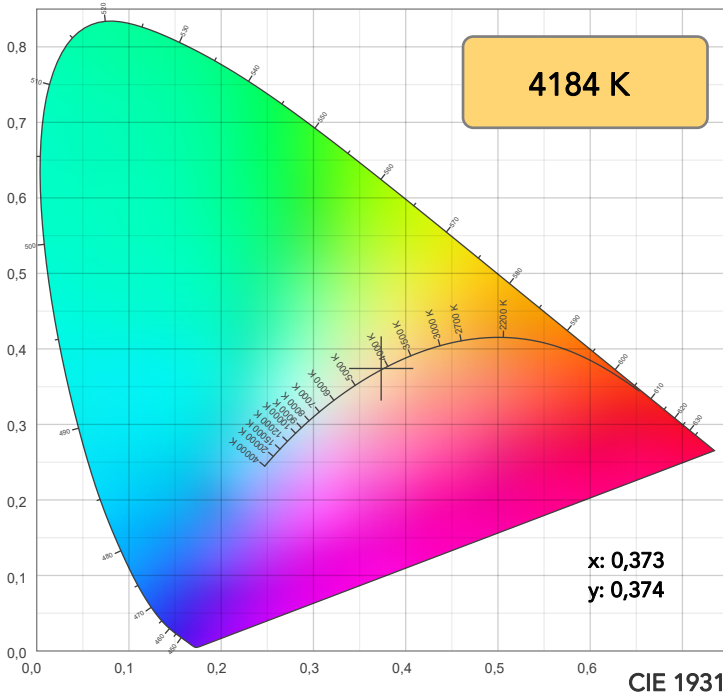

**TM30: 96,1**

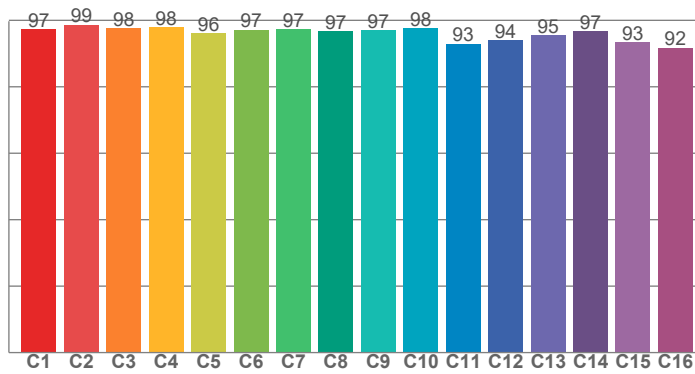

**CRI: 98,1 (R1-R8)**

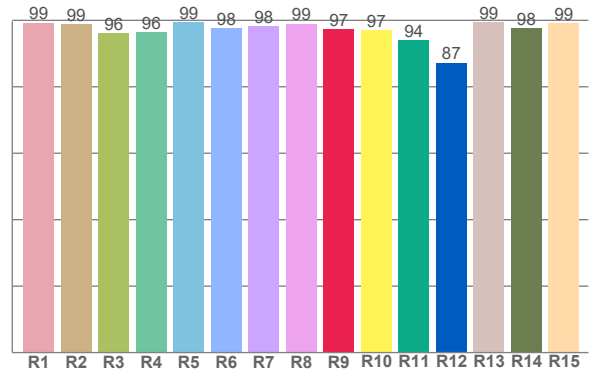

CRI R values, only R1-R8 are used to calculate final CRI value

R1	R2	R3	R4	R5	R6	R7	R8	R9	R10	R11	R12	R13	R14	R15
99,3	98,8	96,2	96,5	99,4	97,5	98,2	99,0	97,4	97,1	94,0	87,3	99,4	97,6	99,1

TM30 C values, 16 binned values out of total of 99 C values

C1	C2	C3	C4	C5	C6	C7	C8	C9	C10	C11	C12	C13	C14	C15	C16
97,3	98,7	97,6	98,0	96,1	97,2	97,3	96,8	97,0	97,7	92,9	94,0	95,4	96,7	93,5	91,8

CQS Q values

Q1	Q2	Q3	Q4	Q5	Q6	Q7	Q8	Q9	Q10	Q11	Q12	Q13	Q14	Q15
98,3	99,7	94,4	97,4	98,1	96,2	98,3	99,3	99,1	99,3	98,9	98,4	98,6	99,5	99,0

**CQS: 97,8**

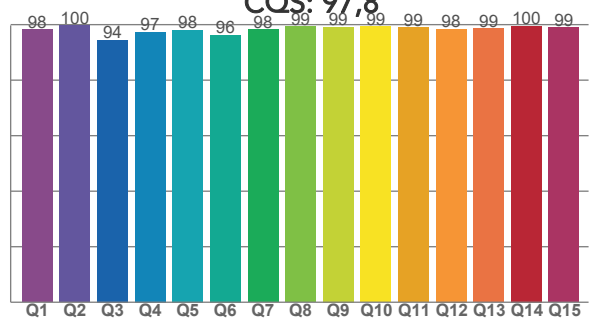

## COLOR PARAMETERS

Color temperature	Color rendering index	Red component	Color fidelity	Color gamut	Color quality scale	Television lighting index	Color coordinate cie 1931	Color coordinate cie 1931	Color deviation from black body
CCT	CRI	CRI R9	TM30 Rf	TM30 Rg	CQS	TLCI	x	y	Δuv
4184 K	98,1	97,4	96,1	101,9	97,8	98	0,373	0,374	0,0009

# TM30 DETAILS

**Rf 96,1**  
Fidelity index Rf

**Rg 101,9**  
Gammut index

Hue Bin	R <sub>f</sub>	Graphic shifts (%)	
		Chroma	Hue
1	97	0%	-1%
2	99	0%	-1%
3	98	0%	1%
4	98	-1%	0%
5	96	-1%	1%
6	97	2%	1%
7	97	1%	1%
8	97	1%	0%
9	97	0%	1%
10	98	-1%	1%
11	93	2%	4%
12	94	3%	2%
13	95	3%	-1%
14	97	2%	0%
15	93	3%	-4%
16	92	2%	-5%

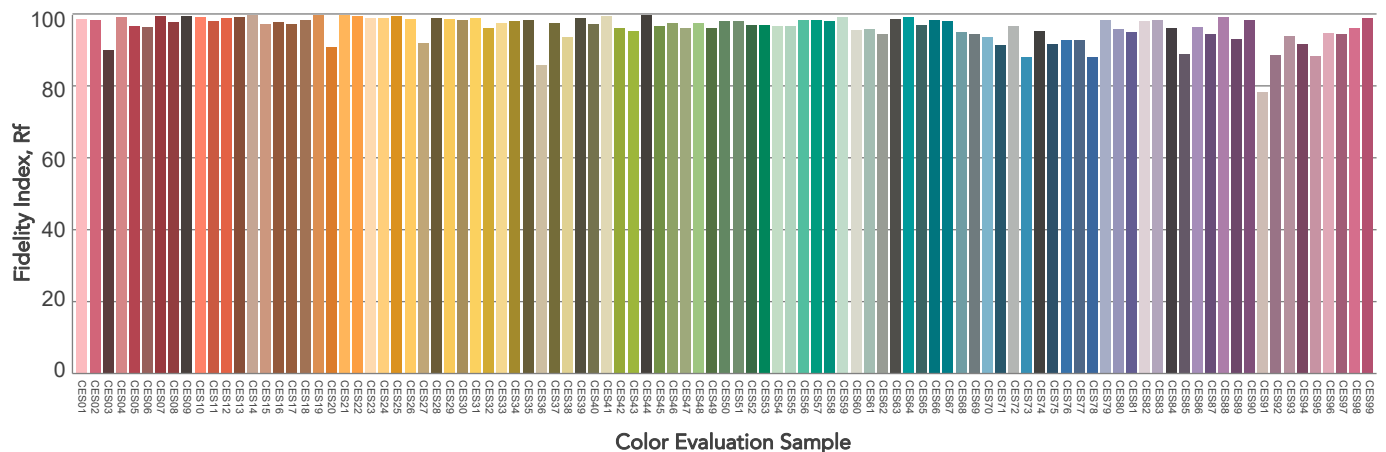
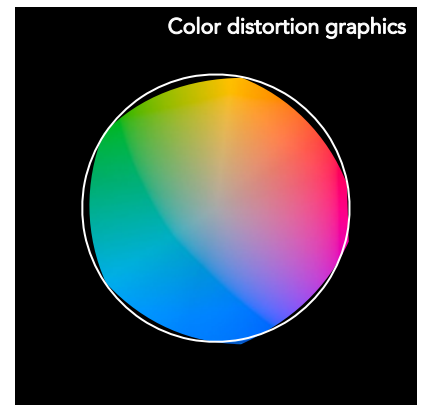
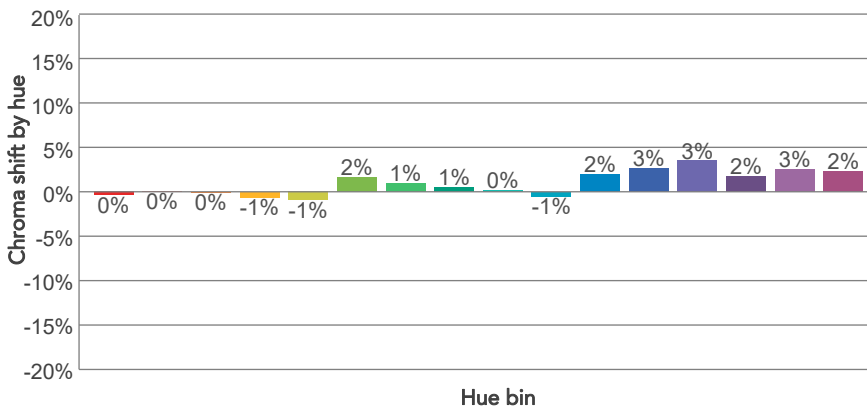
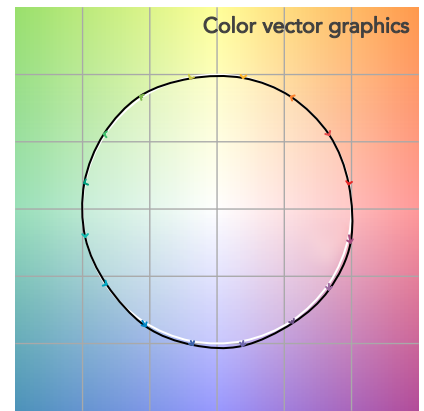
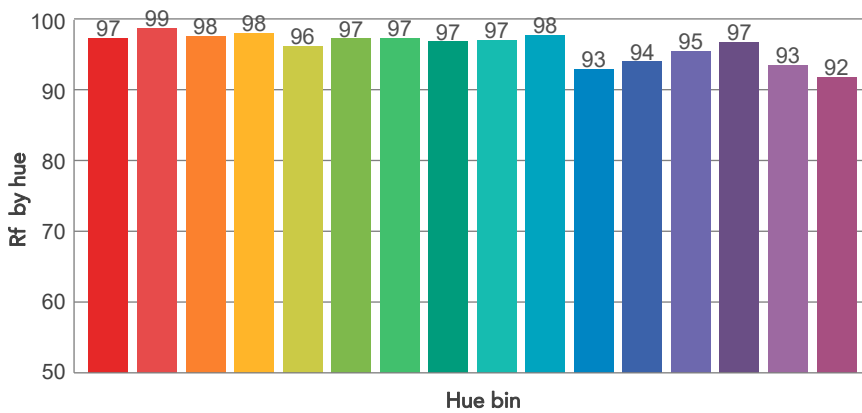
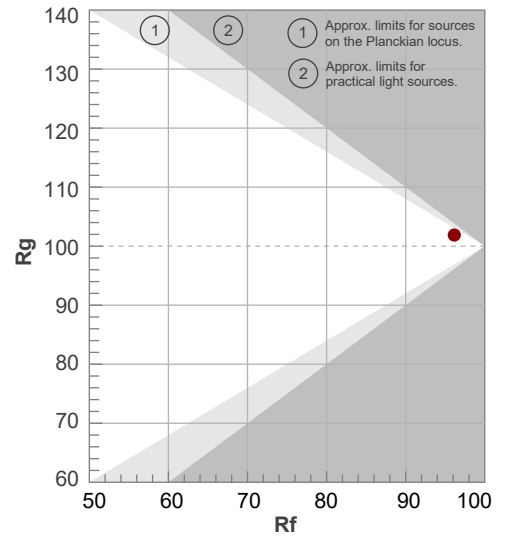

# BEAM DETAILS



Beam angle 50%	Field angle 10%	Cut off angle 2,5%	Intensity ratio in 120° cone	Intensity ratio in 90° cone
18,9°	21,2°	21,8°	100,0%	100,0%

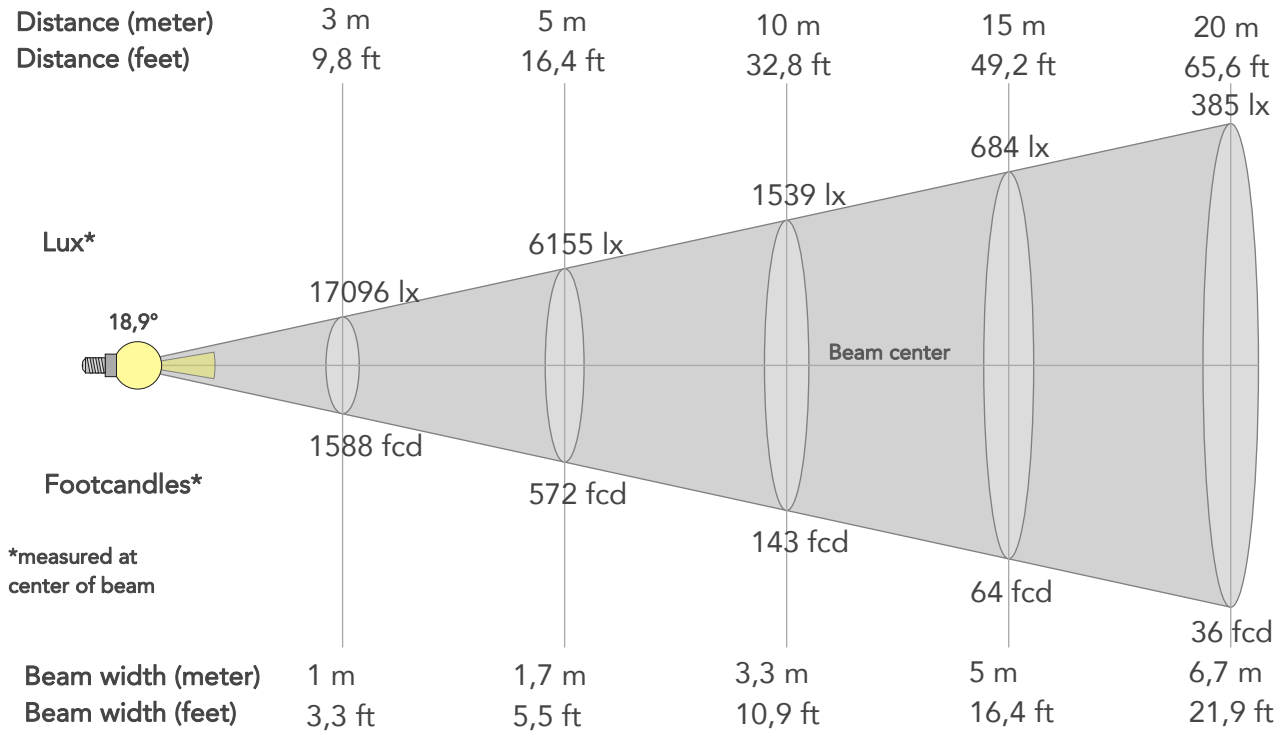

## BEAM INTENSITIES AND WIDTHS

Distance	1m	2m	3m	4m	5m	7,5m	10m	15m	20m	25m	30m	40m	50m
Distance	3,3ft	6,6ft	9,8ft	13,1ft	16,4ft	24,6ft	32,8ft	49,2ft	65,6ft	82ft	98,4ft	131,2ft	164ft
Lux	153866lx	38467lx	17096lx	9617lx	6155lx	2735lx	1539lx	684lx	385lx	246lx	171lx	96lx	62lx
Footcand.	14295fcd	3574fcd	1588fcd	893fcd	572fcd	254fcd	143fcd	64fcd	36fcd	23fcd	16fcd	9fcd	6fcd
Beam wid.	0,3m	0,7m	1m	1,3m	1,7m	2,5m	3,3m	5m	6,7m	8,3m	10m	13,3m	16,7m
Beam wid.	1,1ft	2,2ft	3,3ft	4,4ft	5,5ft	8,2ft	10,9ft	16,4ft	21,9ft	27,4ft	32,8ft	43,8ft	54,7ft

## LINEAR DISTRIBUTION DIAGRAM

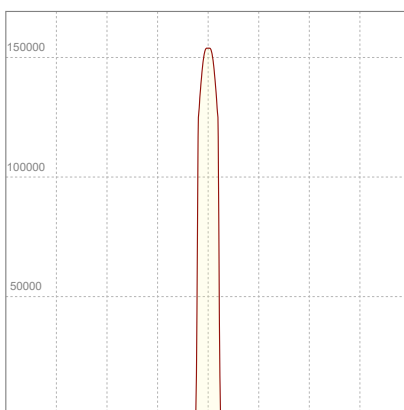

## ELECTRICAL SPECIFICATIONS

Input voltage	Input current	Input power	Power FC	Efficiency
225V	2,01A	439,5W	0,97	28lm/W

# ISO DIAGRAMS

## ISO CANDELA DIAGRAM

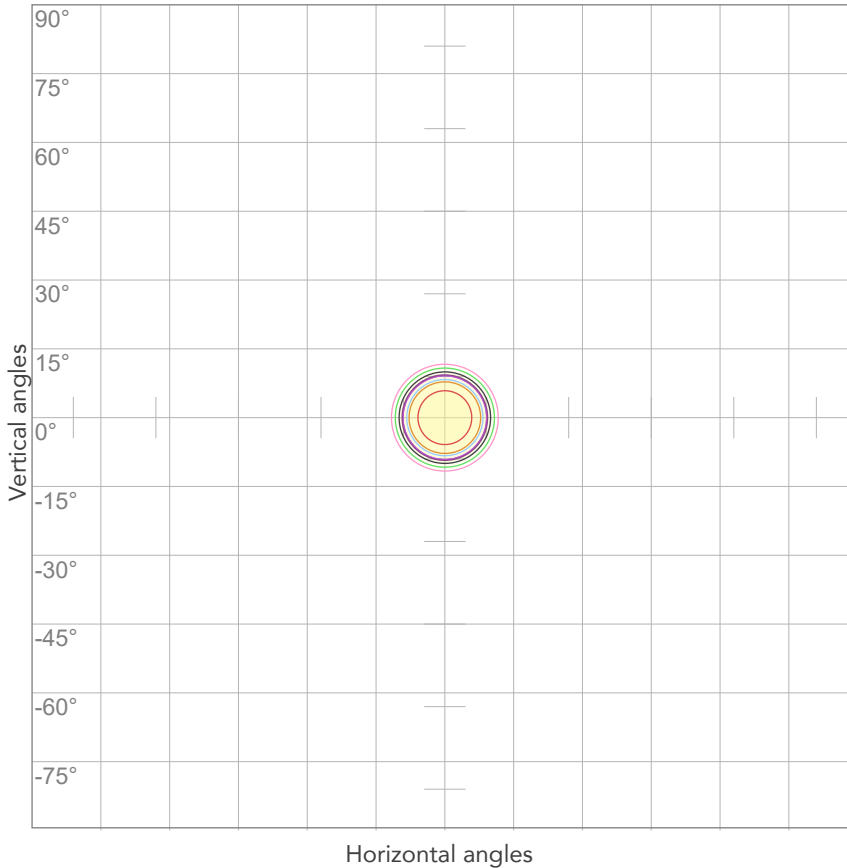

10%	15387 cd
20%	30773 cd
30%	46160 cd
40%	61546 cd
50%	76933 cd
60%	92320 cd
70%	107706 cd
80%	123093 cd

Conditions:

Number of c-planes: 2

Candela at center: 153866 cd

## ISO LUX DIAGRAM

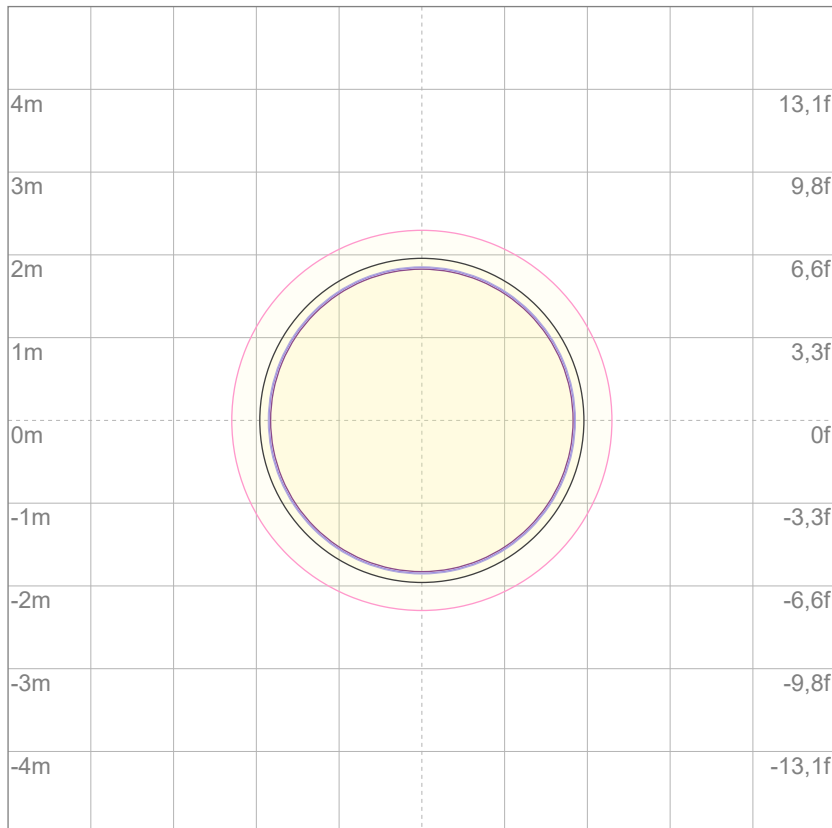

Mounting height: 10 meters (33 feet)

3%	46,2 lx
5%	76,9 lx
10%	154 lx
30%	462 lx
50%	769 lx

Conditions:

Number of c-planes: 2

Lux at center: 1539 lx

*Lux distribution on a surface when lamp is mounted at 10 meters from the surface.*



Total lumen output:

9343 lm

Peak candela output:

115050 cd

Light quality:

CRI: 96,4

Color temperature:

2626 K

**PRODUCT NAME:**

ECLFWHPVW

**MEASURAMENT CONDITIONS:**

Beam angle:

PRL19

Target:

Warm White

Operator:

Giuseppe della Peruta

Date and time:

07/01/2026 12:42:15

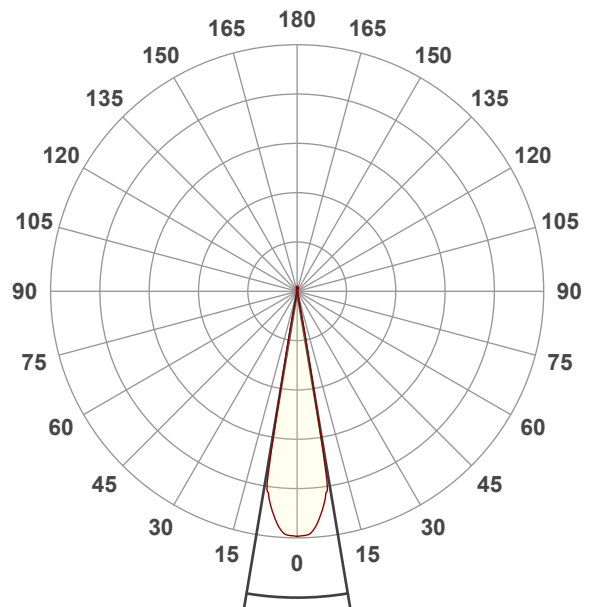

Beam angle 50%: 19°  
Field angle 10%: 21,2°  
Cut off angle 2.5%: 21,8°

**Spectra**

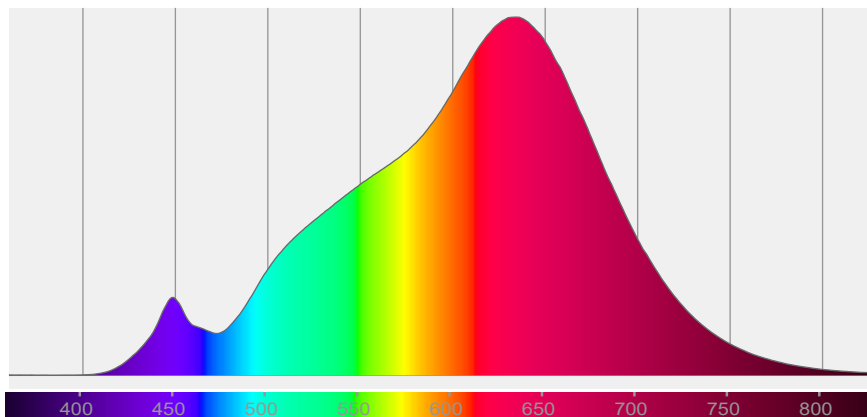

# COLOR DETAILS

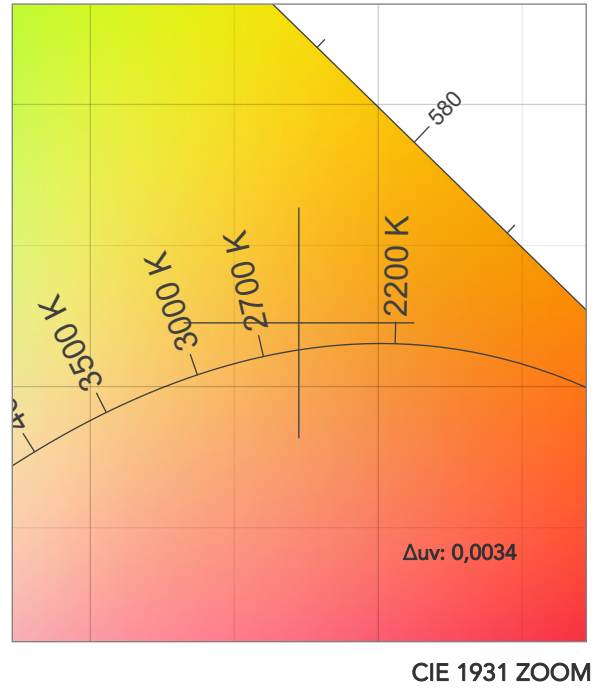
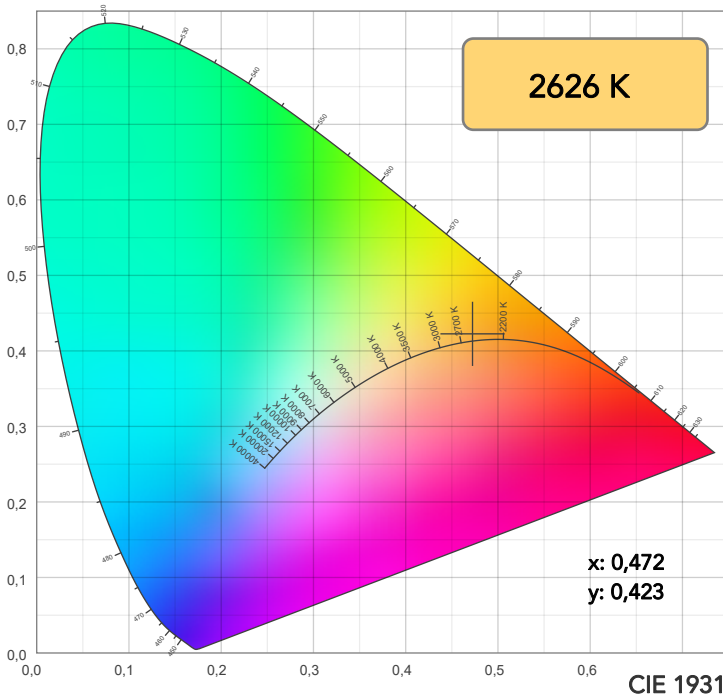

**TM30: 96,0**

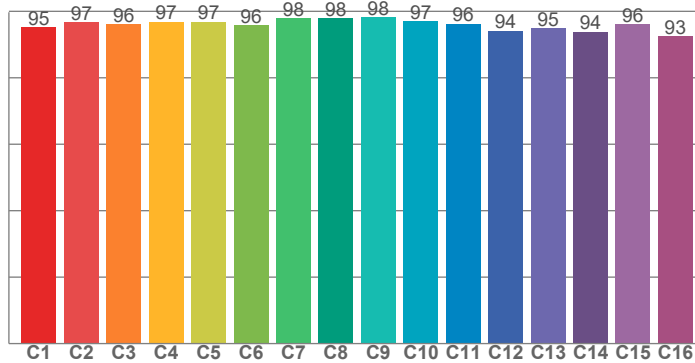

**CRI: 96,4 (R1-R8)**

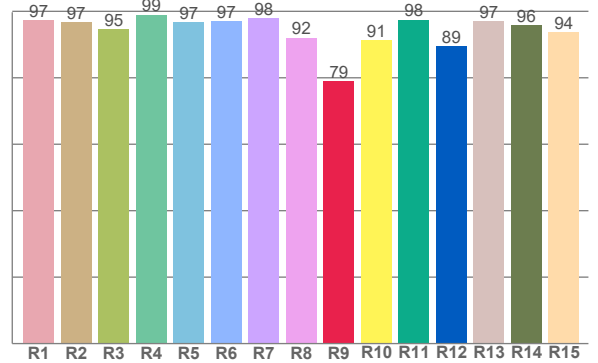

**CQS: 91,4**

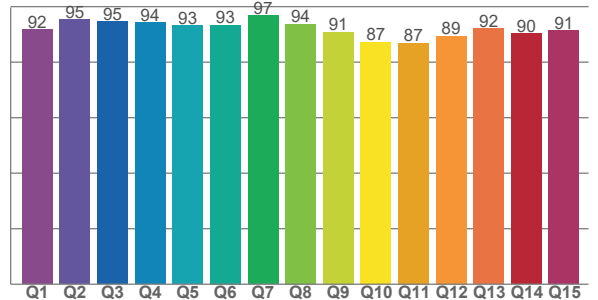

CRI R values, only R1-R8 are used to calculate final CRI value

R1	R2	R3	R4	R5	R6	R7	R8	R9	R10	R11	R12	R13	R14	R15
97,3	96,7	94,5	99,0	96,8	97,2	98,0	92,1	78,9	91,3	97,5	89,4	97,0	95,9	93,6

TM30 C values, 16 binned values out of total of 99 C values

C1	C2	C3	C4	C5	C6	C7	C8	C9	C10	C11	C12	C13	C14	C15	C16
95,3	96,7	96,1	96,9	96,8	95,8	97,9	97,9	98,2	97,0	96,2	94,2	94,9	93,9	96,1	92,6

CQS Q values

Q1	Q2	Q3	Q4	Q5	Q6	Q7	Q8	Q9	Q10	Q11	Q12	Q13	Q14	Q15
91,7	95,3	94,7	94,3	93,3	93,4	96,8	93,8	90,9	87,2	87,0	89,4	92,2	90,4	91,5

## COLOR PARAMETERS

Color temperature	Color rendering index	Red component	Color fidelity	Color gamut	Color quality scale	Television lighting index	Color coordinate cie 1931	Color coordinate cie 1931	Color deviation from black body
CCT	CRI	CRI R9	TM30 Rf	TM30 Rg	CQS	TLCI	x	y	$\Delta uv$
2626 K	96,4	78,9	96,0	99,2	91,4	96	0,472	0,423	0,0034

# TM30 DETAILS

**Rf 96,0**  
Fidelity index Rf

**Rg 99,2**  
Gammut index

Hue Bin	R <sub>f</sub>	Graphic shifts (%)	
		Chroma	Hue
1	95	-2%	-1%
2	97	-2%	0%
3	96	-2%	1%
4	97	-1%	1%
5	97	-1%	2%
6	96	1%	3%
7	98	0%	0%
8	98	1%	0%
9	98	-1%	-1%
10	97	-1%	1%
11	96	0%	2%
12	94	2%	-1%
13	95	1%	-4%
14	94	2%	-4%
15	96	0%	-2%
16	93	-1%	-5%

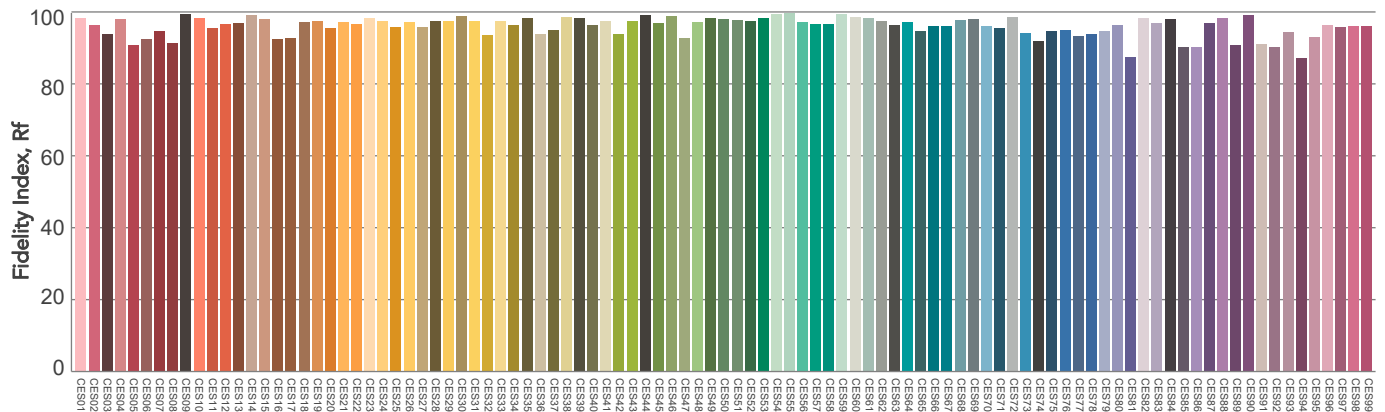
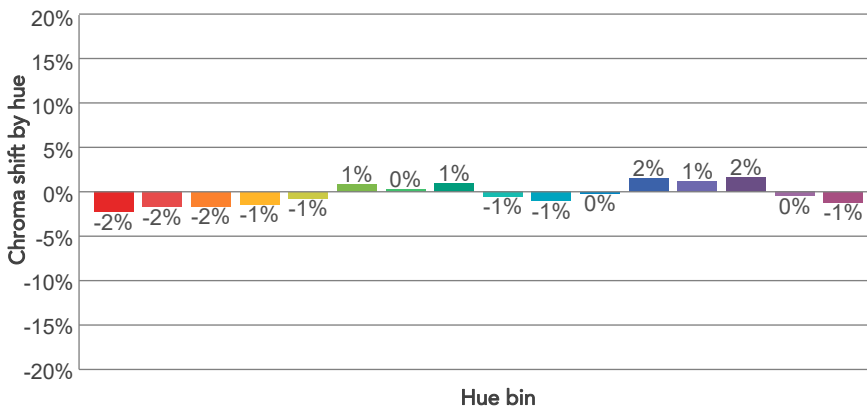
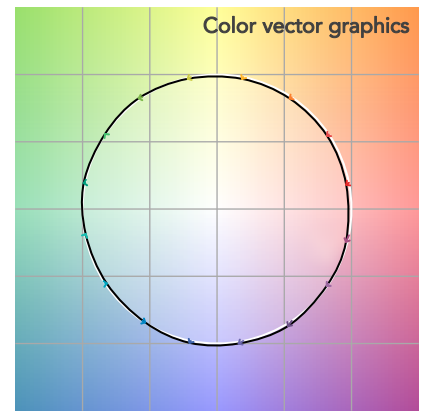
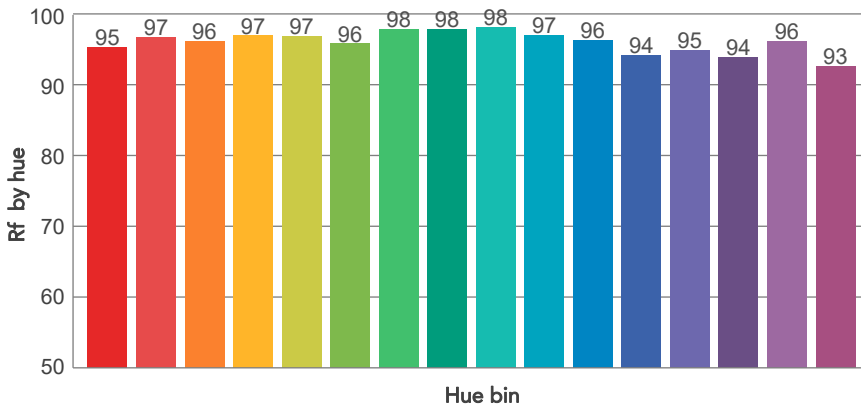
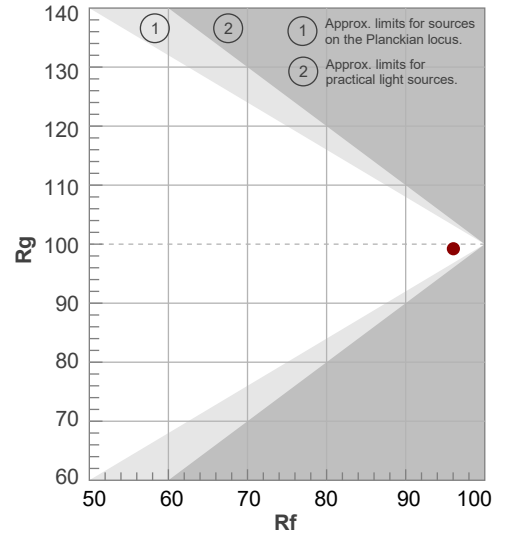

Color Evaluation Sample

# BEAM DETAILS



Beam angle 50%	Field angle 10%	Cut off angle 2,5%	Intensity ratio in 120° cone	Intensity ratio in 90° cone
19°	21,2°	21,8°	100,0%	100,0%

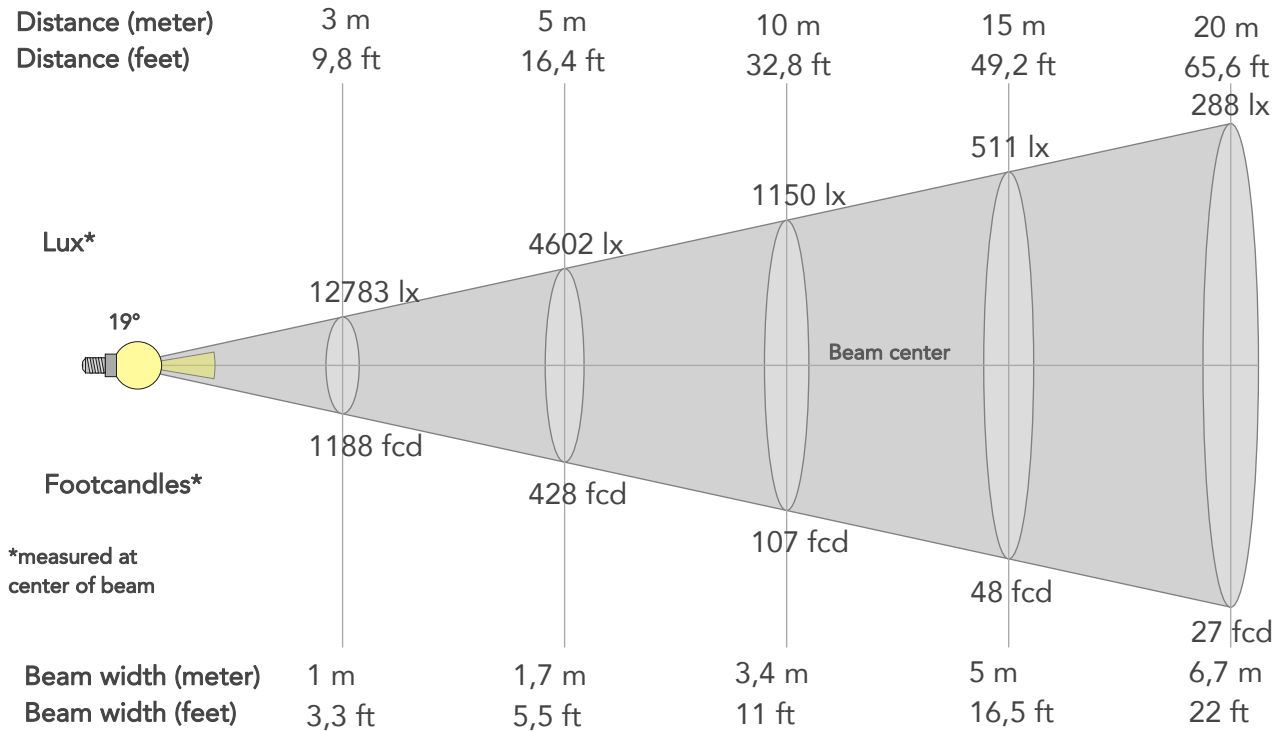

## BEAM INTENSITIES AND WIDTHS

Distance	1m	2m	3m	4m	5m	7,5m	10m	15m	20m	25m	30m	40m	50m
Distance	3,3ft	6,6ft	9,8ft	13,1ft	16,4ft	24,6ft	32,8ft	49,2ft	65,6ft	82ft	98,4ft	131,2ft	164ft
Lux	115050lx	28762lx	12783lx	7191lx	4602lx	2045lx	1150lx	511lx	288lx	184lx	128lx	72lx	46lx
Footcand.	10688fcd	2672fcd	1188fcd	668fcd	428fcd	190fcd	107fcd	48fcd	27fcd	17fcd	12fcd	7fcd	4fcd
Beam wid.	0,3m	0,7m	1m	1,3m	1,7m	2,5m	3,4m	5m	6,7m	8,4m	10,1m	13,4m	16,8m
Beam wid.	1,1ft	2,2ft	3,3ft	4,4ft	5,5ft	8,2ft	11ft	16,5ft	22ft	27,5ft	33ft	44ft	55ft

## LINEAR DISTRIBUTION DIAGRAM

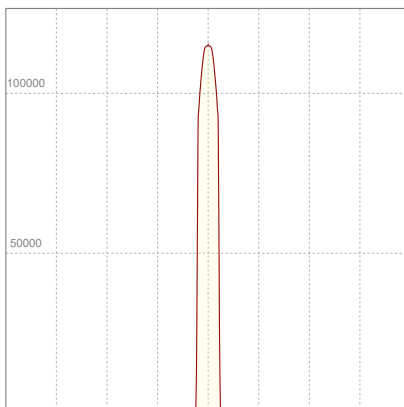

## ELECTRICAL SPECIFICATIONS

Input voltage	Input current	Input power	Power FC	Efficiency
226V	1,75A	382,2W	0,97	24lm/W

# ISO DIAGRAMS

## ISO CANDELA DIAGRAM

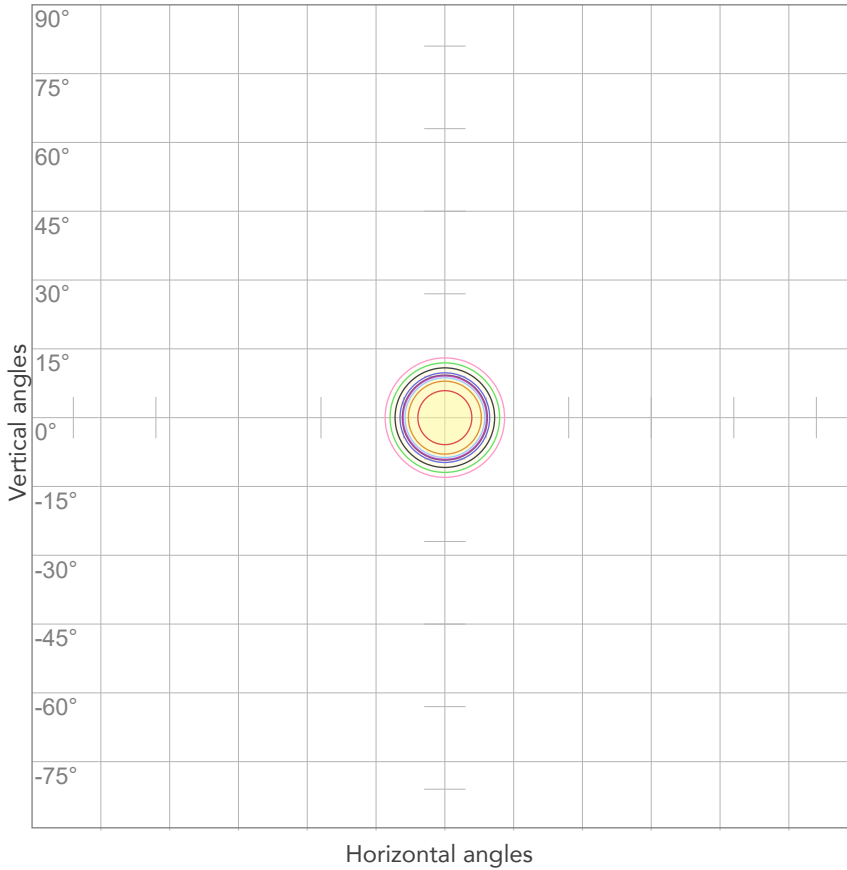

10%	11505 cd
20%	23010 cd
30%	34515 cd
40%	46020 cd
50%	57525 cd
60%	69030 cd
70%	80535 cd
80%	92040 cd

Conditions:

Number of c-planes: 2

Candela at center: 115050 cd

## ISO LUX DIAGRAM

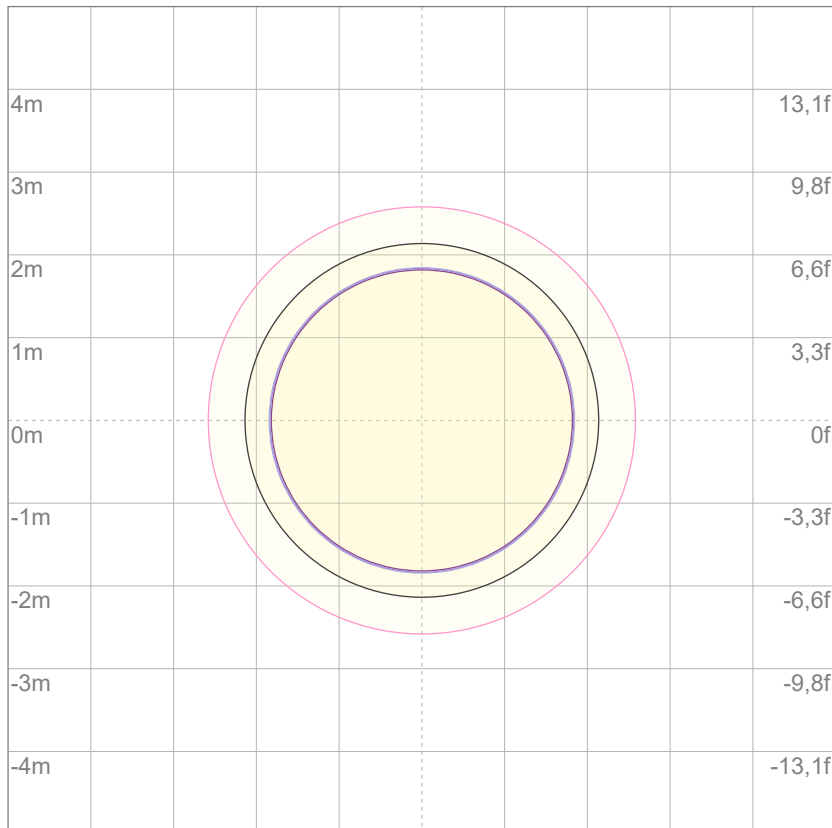

3%	34,5 lx
5%	57,5 lx
10%	115 lx
30%	345 lx
50%	575 lx

Conditions:

Number of c-planes: 2

Lux at center: 1150 lx

*Lux distribution on a surface when lamp is mounted at 10 meters from the surface.*

Mounting height: 10 meters (33 feet)



Total lumen output:

12041 lm

Peak candela output:

149619 cd

Light quality:

CRI: 93,8

Color temperature:

6518 K

PRODUCT NAME:

ECLFWHPVW

MEASURAMENT CONDITIONS:

Beam angle:

PRL19

Target:

Cold White

Operator:

Giuseppe della Peruta

Date and time:

07/01/2026 12:47:18

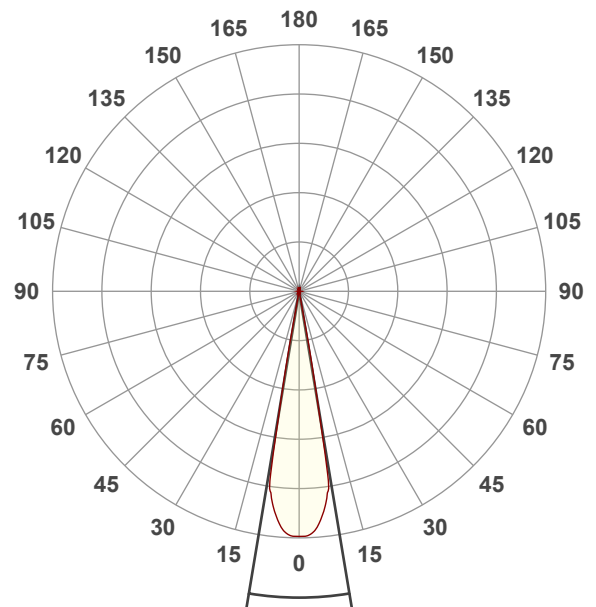

Beam angle 50%: 18,9°

Field angle 10%: 21,2°

Cut off angle 2.5%: 21,7°

Spectra

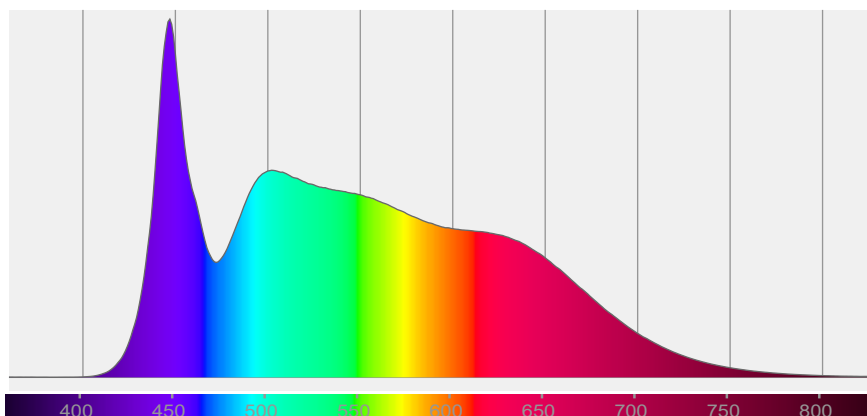

# COLOR DETAILS

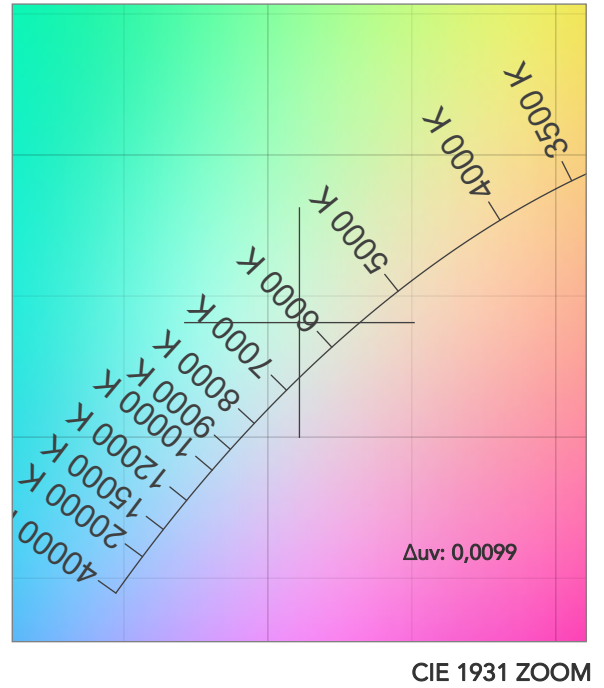
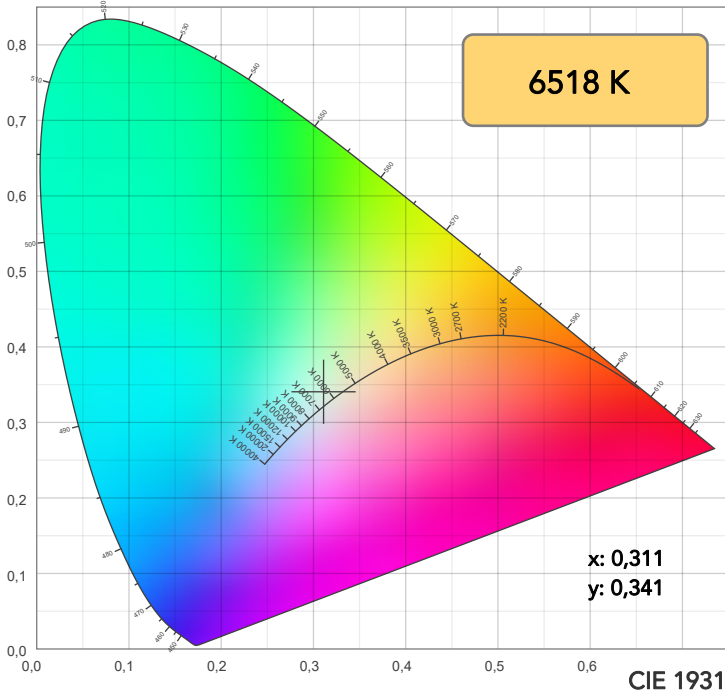

**TM30: 93,7**

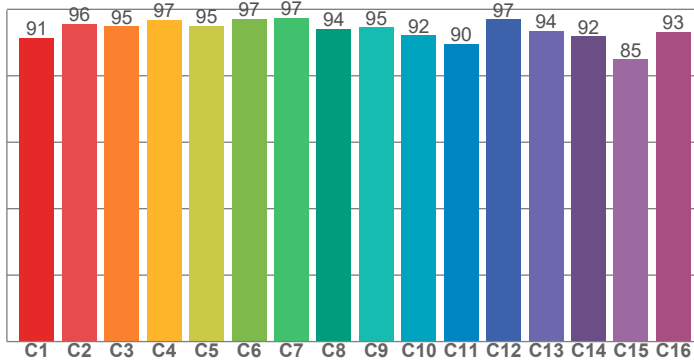

**CRI: 93,8 (R1-R8)**

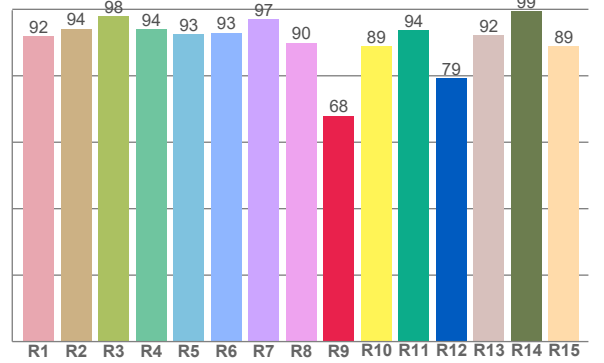

**CQS: 95,3**

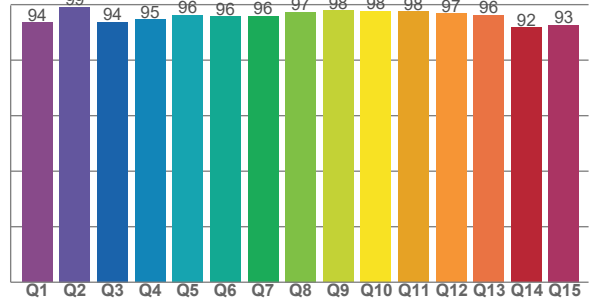

CRI R values, only R1-R8 are used to calculate final CRI value

R1	R2	R3	R4	R5	R6	R7	R8	R9	R10	R11	R12	R13	R14	R15
92,0	94,2	98,0	94,0	92,5	92,9	97,0	89,9	68,0	88,9	93,8	79,3	92,2	99,4	88,9

TM30 C values, 16 binned values out of total of 99 C values

C1	C2	C3	C4	C5	C6	C7	C8	C9	C10	C11	C12	C13	C14	C15	C16
91,5	95,6	94,9	96,9	95,0	97,2	97,4	94,1	94,6	92,2	89,6	97,0	93,5	91,9	84,9	93,2

CQS Q values

Q1	Q2	Q3	Q4	Q5	Q6	Q7	Q8	Q9	Q10	Q11	Q12	Q13	Q14	Q15
93,6	99,2	93,7	94,6	96,3	95,7	95,9	97,4	97,9	97,8	97,5	96,7	96,2	91,7	92,7

## COLOR PARAMETERS

Color temperature	Color rendering index	Red component	Color fidelity	Color gamut	Color quality scale	Television lighting index	Color coordinate cie 1931	Color coordinate cie 1931	Color deviation from black body
CCT	CRI	CRI R9	TM30 Rf	TM30 Rg	CQS	TLCI	x	y	Δuv
6518 K	93,8	68,0	93,7	98,4	95,3	99	0,311	0,341	0,0099

# TM30 DETAILS

**Rf 93,7**  
Fidelity index Rf

**Rg 98,4**  
Gammut index

Hue Bin	R <sub>f</sub>	Graphic shifts (%)	
		Chroma	Hue
1	91	-3%	-2%
2	96	-2%	0%
3	95	-2%	1%
4	97	-2%	0%
5	95	-3%	-1%
6	97	-1%	0%
7	97	-1%	0%
8	94	-3%	0%
9	95	-3%	3%
10	92	-1%	5%
11	90	1%	6%
12	97	2%	0%
13	94	3%	-3%
14	92	1%	-5%
15	85	6%	-12%
16	93	-1%	-3%

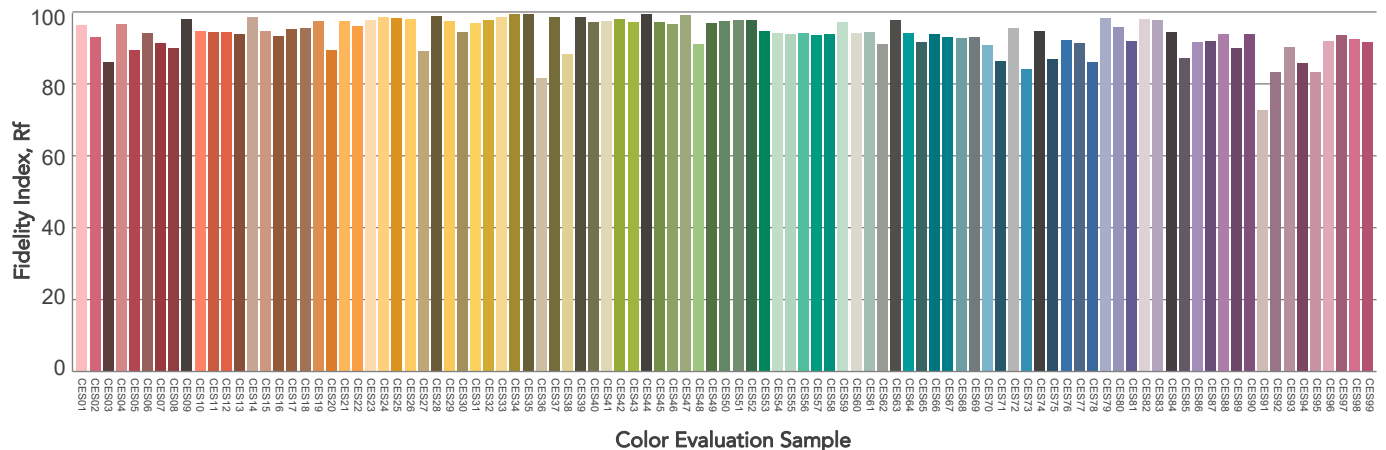
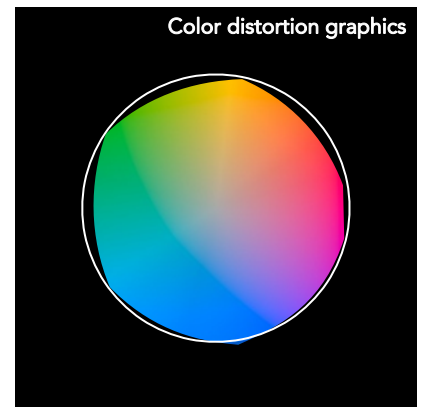
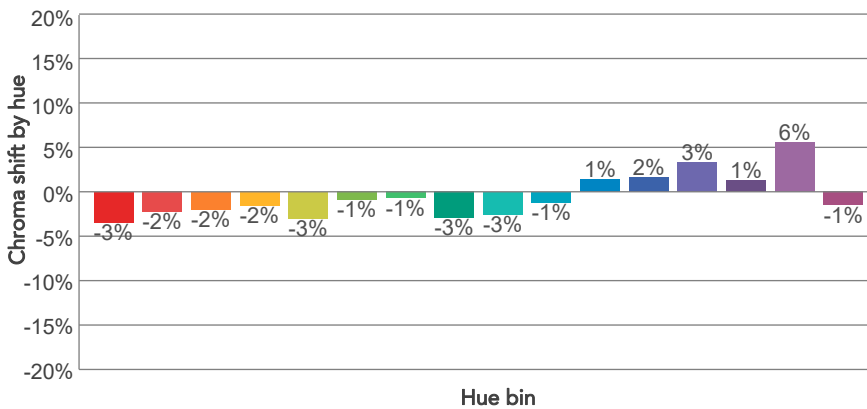
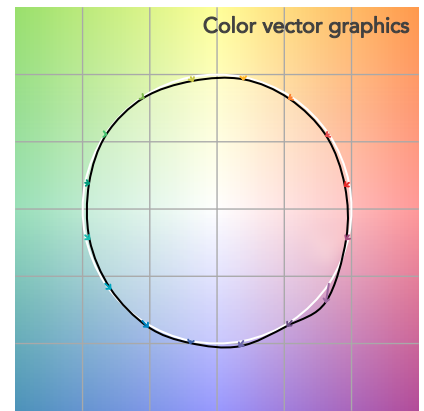
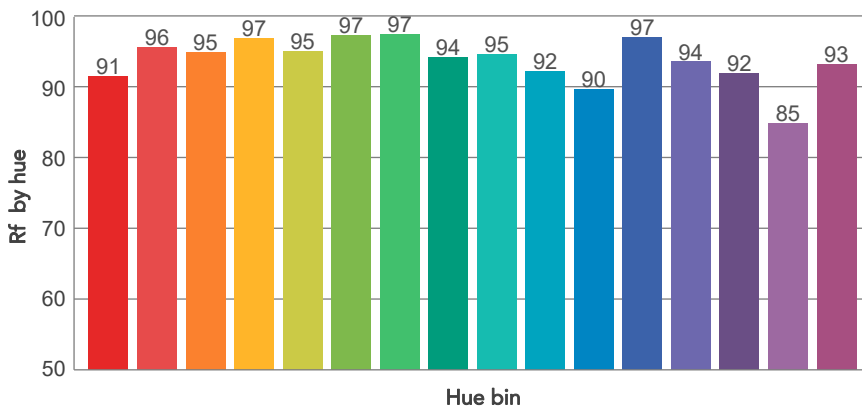
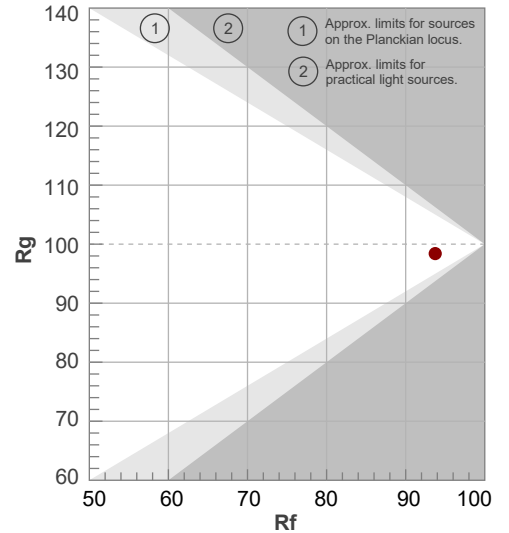

# BEAM DETAILS



Beam angle 50%	Field angle 10%	Cut off angle 2,5%	Intensity ratio in 120° cone	Intensity ratio in 90° cone
18,9°	21,2°	21,7°	100,0%	100,0%

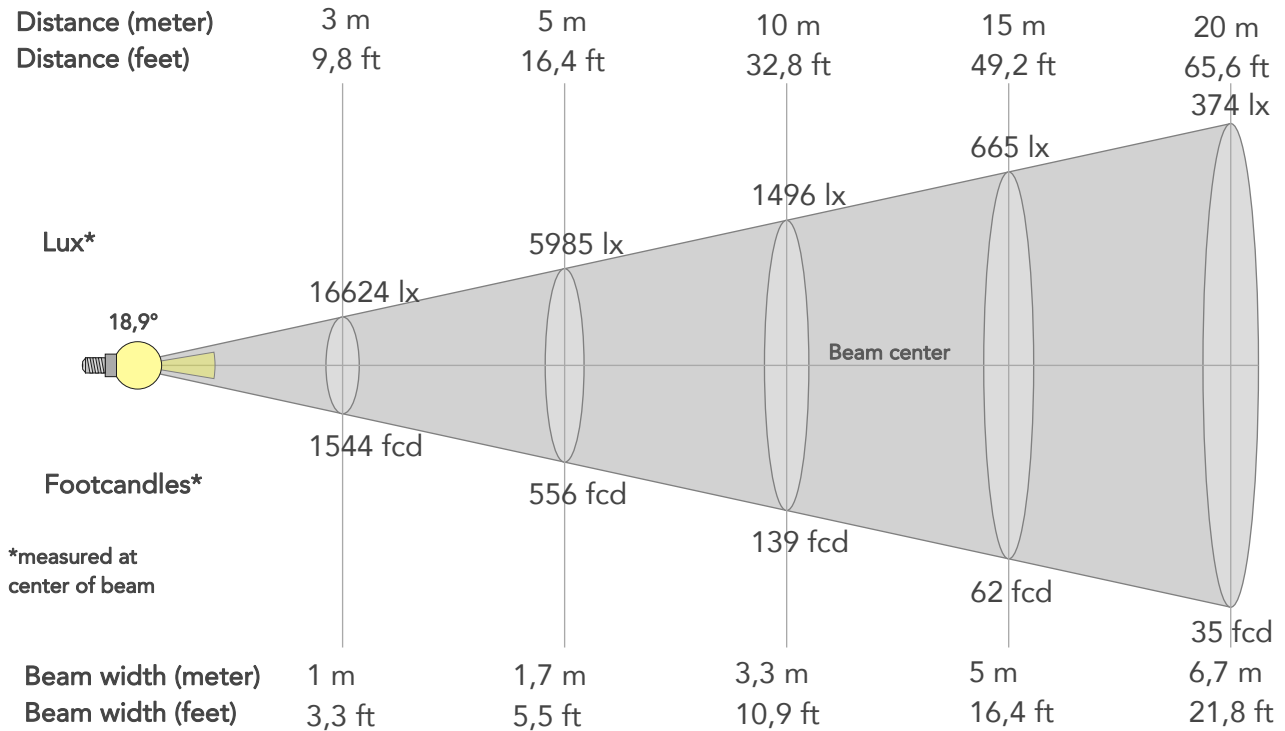

## BEAM INTENSITIES AND WIDTHS

Distance	1m	2m	3m	4m	5m	7,5m	10m	15m	20m	25m	30m	40m	50m
Distance	3,3ft	6,6ft	9,8ft	13,1ft	16,4ft	24,6ft	32,8ft	49,2ft	65,6ft	82ft	98,4ft	131,2ft	164ft
Lux	149619lx	37405lx	16624lx	9351lx	5985lx	2660lx	1496lx	665lx	374lx	239lx	166lx	94lx	60lx
Footcand.	13900fcd	3475fcd	1544fcd	869fcd	556fcd	247fcd	139fcd	62fcd	35fcd	22fcd	15fcd	9fcd	6fcd
Beam wid.	0,3m	0,7m	1m	1,3m	1,7m	2,5m	3,3m	5m	6,7m	8,3m	10m	13,3m	16,6m
Beam wid.	1,1ft	2,2ft	3,3ft	4,4ft	5,5ft	8,2ft	10,9ft	16,4ft	21,8ft	27,3ft	32,7ft	43,7ft	54,6ft

## LINEAR DISTRIBUTION DIAGRAM

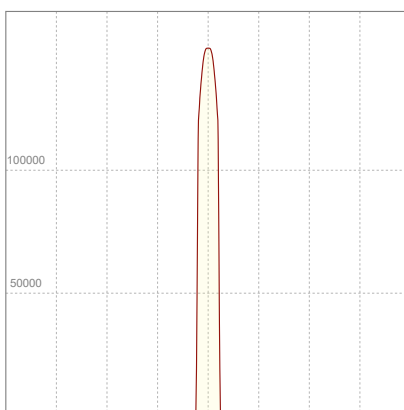

## ELECTRICAL SPECIFICATIONS

Input voltage	Input current	Input power	Power FC	Efficiency
226V	1,75A	380,3W	0,96	32lm/W

# ISO DIAGRAMS

## ISO CANDELA DIAGRAM

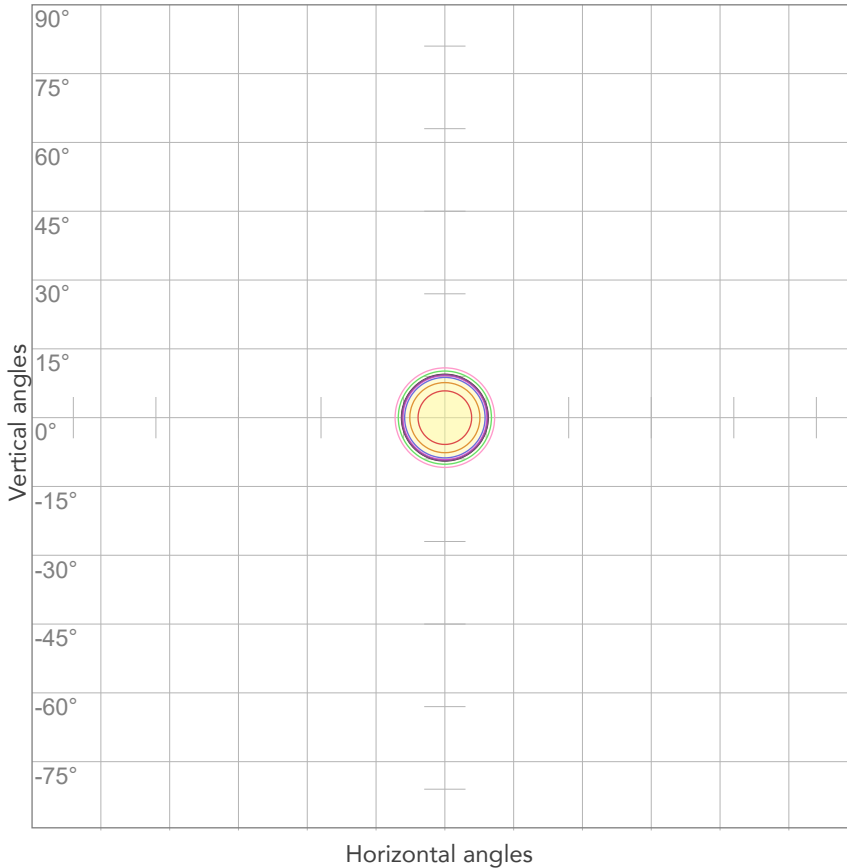

10%	14962 cd
20%	29924 cd
30%	44886 cd
40%	59848 cd
50%	74809 cd
60%	89771 cd
70%	104733 cd
80%	119695 cd

Conditions:

Number of c-planes: 2

Candela at center: 149619 cd

## ISO LUX DIAGRAM

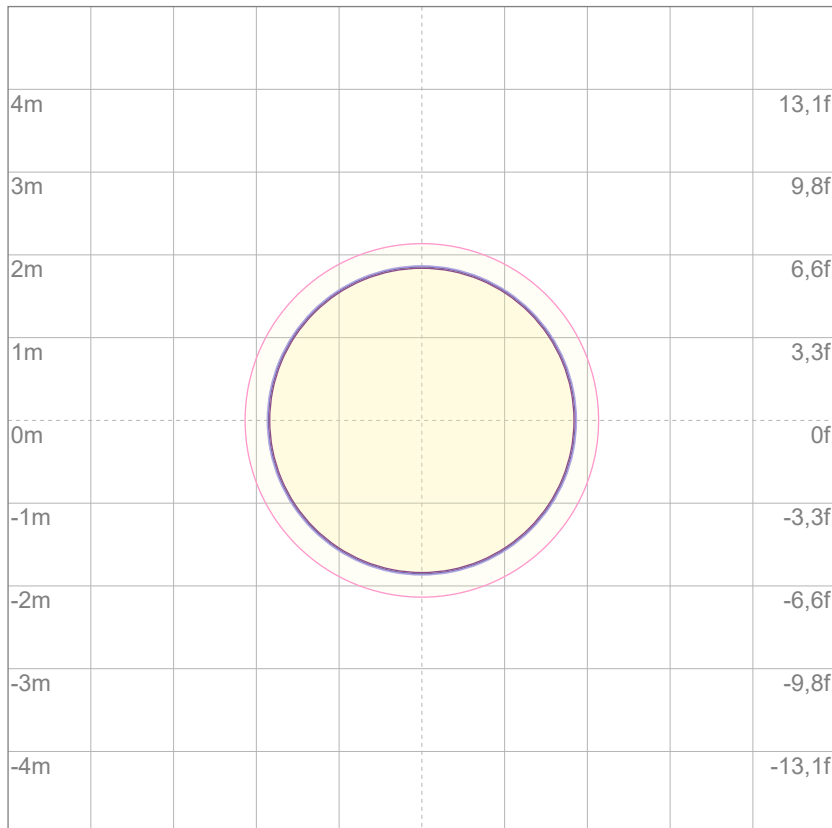

Mounting height: 10 meters (33 feet)

3%	44,9 lx
5%	74,8 lx
10%	150 lx
30%	449 lx
50%	748 lx

Conditions:

Number of c-planes: 2

Lux at center: 1496 lx

*Lux distribution on a surface when lamp is mounted at 10 meters from the surface.*



Total lumen output:

10191 lm

Peak candela output:

125375 cd

Light quality:

CRI: 97,2

Color temperature:

2782 K

**PRODUCT NAME:**

ECLFWHPVW

**MEASURAMENT CONDITIONS:**

Beam angle:

PRL19

Target:

2800K

Operator:

Giuseppe della Peruta

Date and time:

07/01/2026 12:34:47

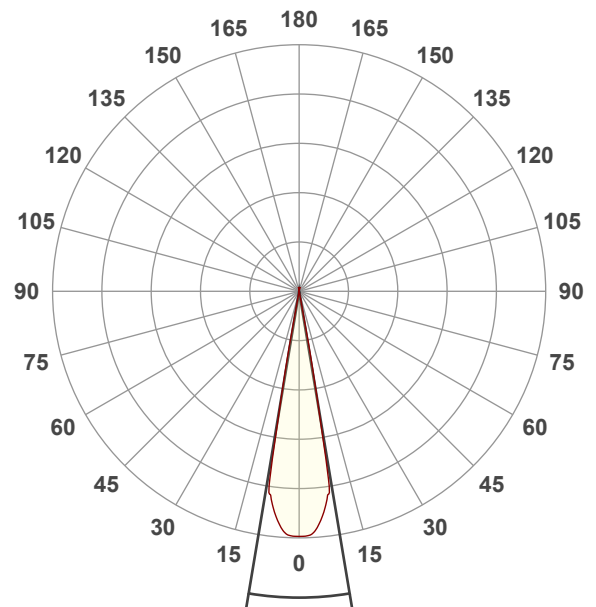

Beam angle 50%: 19°

Field angle 10%: 21,2°

Cut off angle 2.5%: 21,7°

Spectra

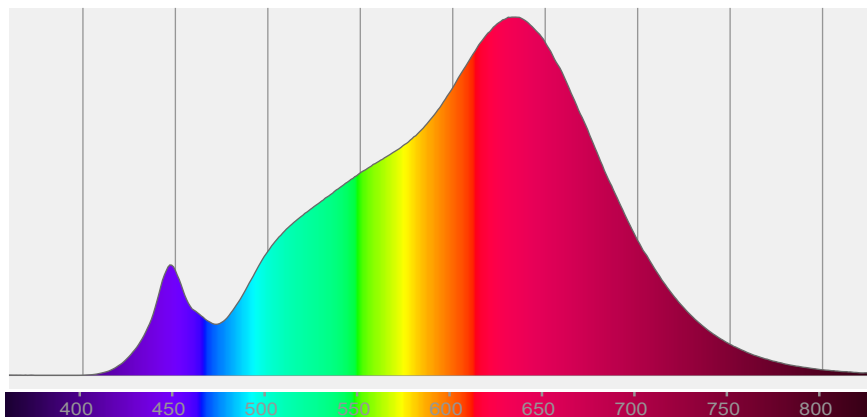

# COLOR DETAILS

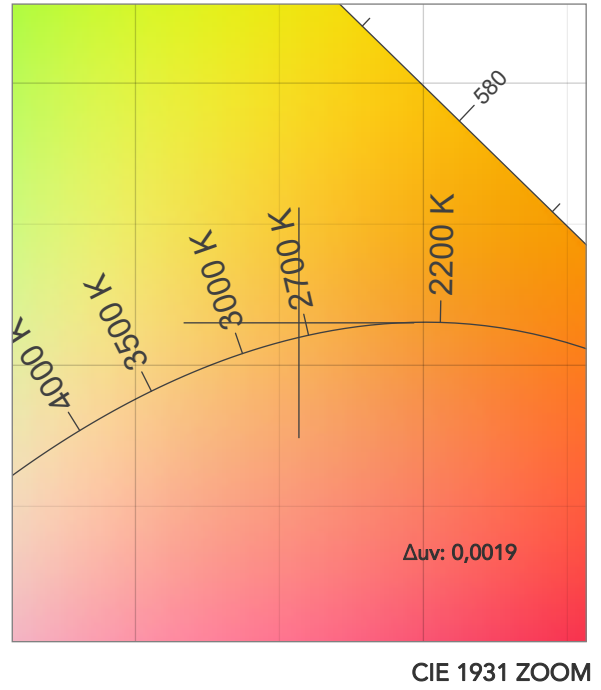
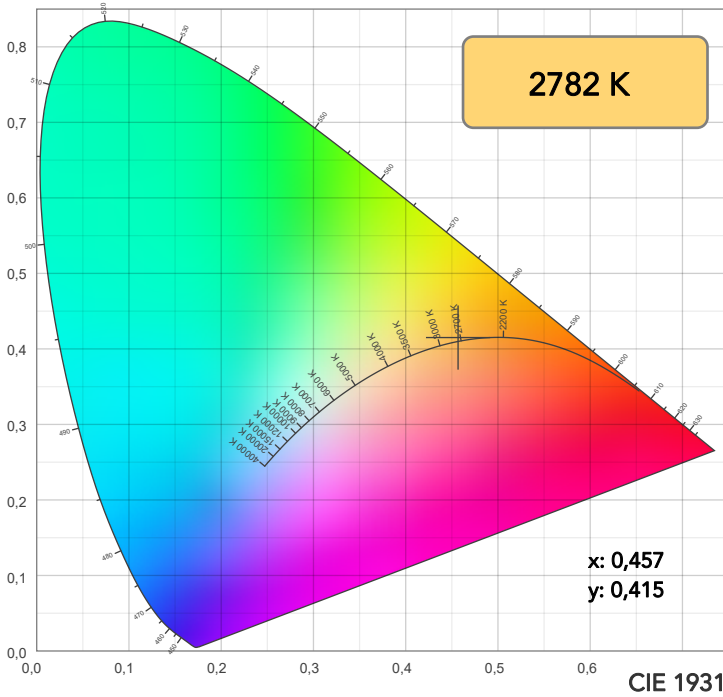

**TM30: 96,0**

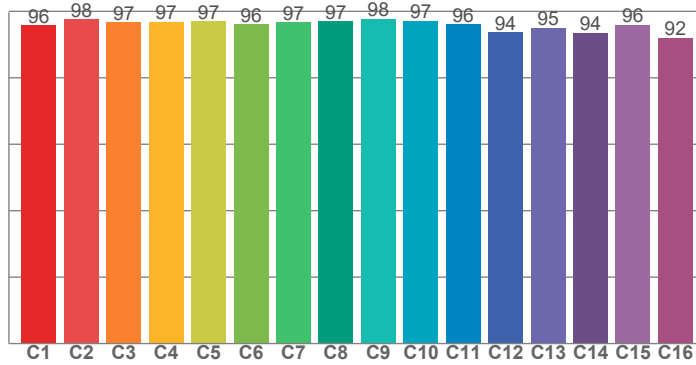

**CRI: 97,2 (R1-R8)**

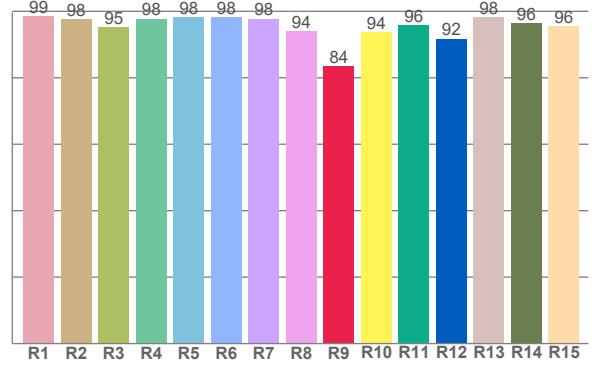

**CQS: 94,4**

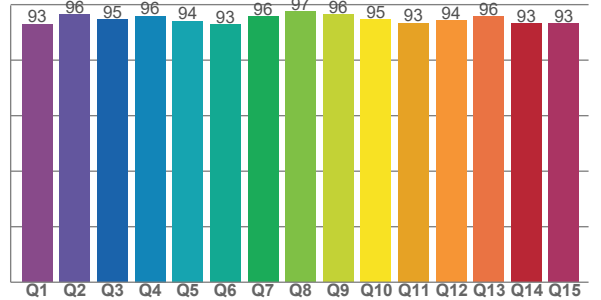

CRI R values, only R1-R8 are used to calculate final CRI value

R1	R2	R3	R4	R5	R6	R7	R8	R9	R10	R11	R12	R13	R14	R15
98,7	97,7	95,2	97,8	98,2	98,2	97,8	93,9	83,6	93,8	95,8	91,8	98,4	96,4	95,6

TM30 C values, 16 binned values out of total of 99 C values

C1	C2	C3	C4	C5	C6	C7	C8	C9	C10	C11	C12	C13	C14	C15	C16
95,8	97,6	96,6	96,8	97,0	96,0	96,6	97,1	97,7	97,2	96,1	93,7	95,0	93,6	96,0	92,1

CQS Q values

Q1	Q2	Q3	Q4	Q5	Q6	Q7	Q8	Q9	Q10	Q11	Q12	Q13	Q14	Q15
92,9	96,4	94,7	95,9	94,0	92,8	95,7	97,5	96,4	94,6	93,4	94,4	95,8	93,2	93,2

## COLOR PARAMETERS

Color temperature	Color rendering index	Red component	Color fidelity	Color gamut	Color quality scale	Television lighting index	Color coordinate cie 1931	Color coordinate cie 1931	Color deviation from black body
CCT	CRI	CRI R9	TM30 Rf	TM30 Rg	CQS	TLCI	x	y	Δuv
2782 K	97,2	83,6	96,0	100,9	94,4	97	0,457	0,415	0,0019

# TM30 DETAILS

**Rf 96,0**  
Fidelity index Rf

**Rg 100,9**  
Gammut index

Hue Bin	R <sub>f</sub>	Graphic shifts (%)	
		Chroma	Hue
1	96	-2%	-1%
2	98	-1%	0%
3	97	-1%	1%
4	97	0%	1%
5	97	1%	2%
6	96	2%	1%
7	97	1%	-2%
8	97	2%	-1%
9	98	0%	-1%
10	97	-1%	0%
11	96	0%	2%
12	94	2%	0%
13	95	2%	-3%
14	94	3%	-4%
15	96	0%	-2%
16	92	0%	-6%

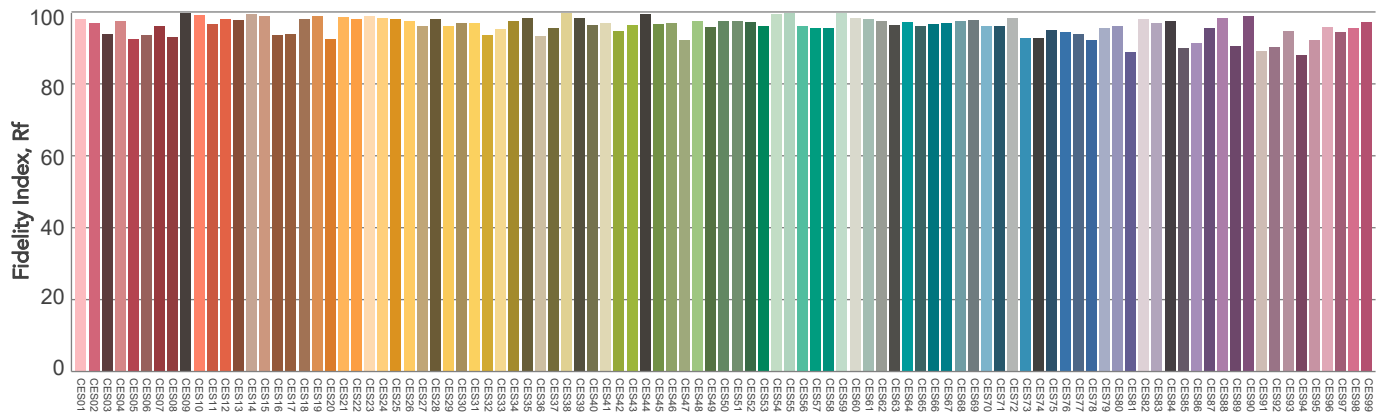
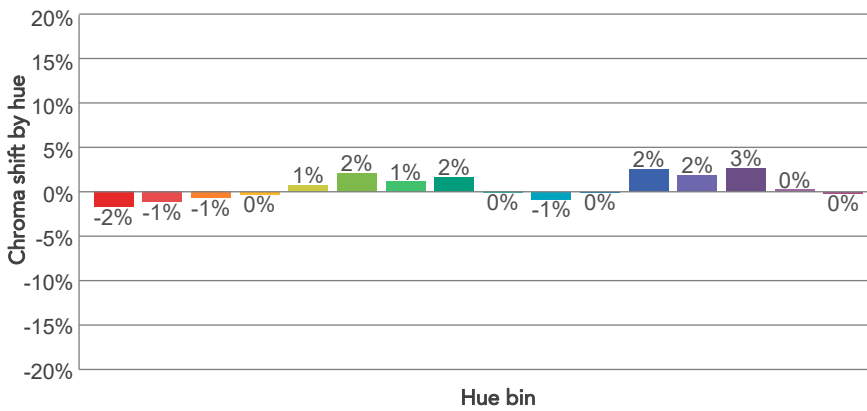
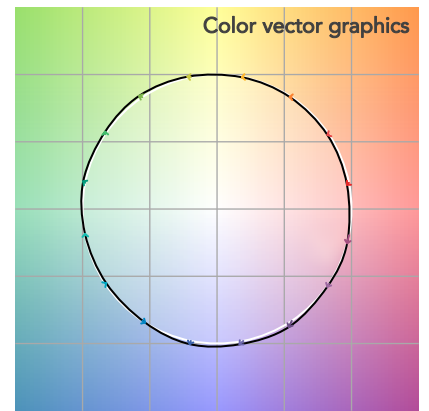
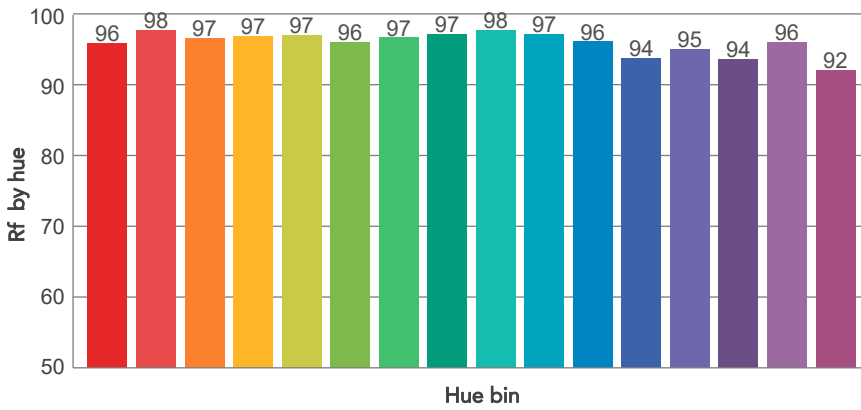
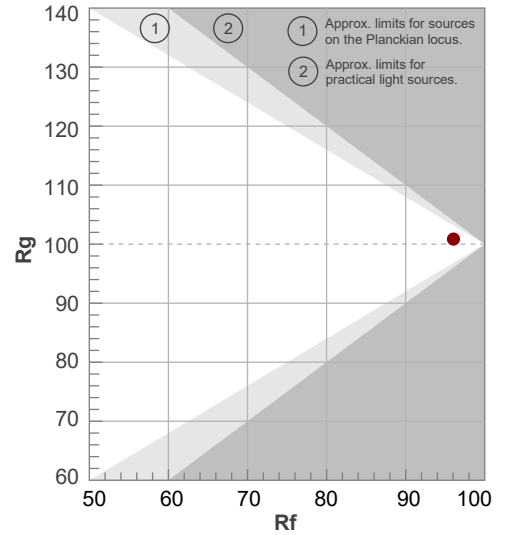

# BEAM DETAILS



Beam angle 50%	Field angle 10%	Cut off angle 2,5%	Intensity ratio in 120° cone	Intensity ratio in 90° cone
19°	21,2°	21,7°	100,0%	100,0%

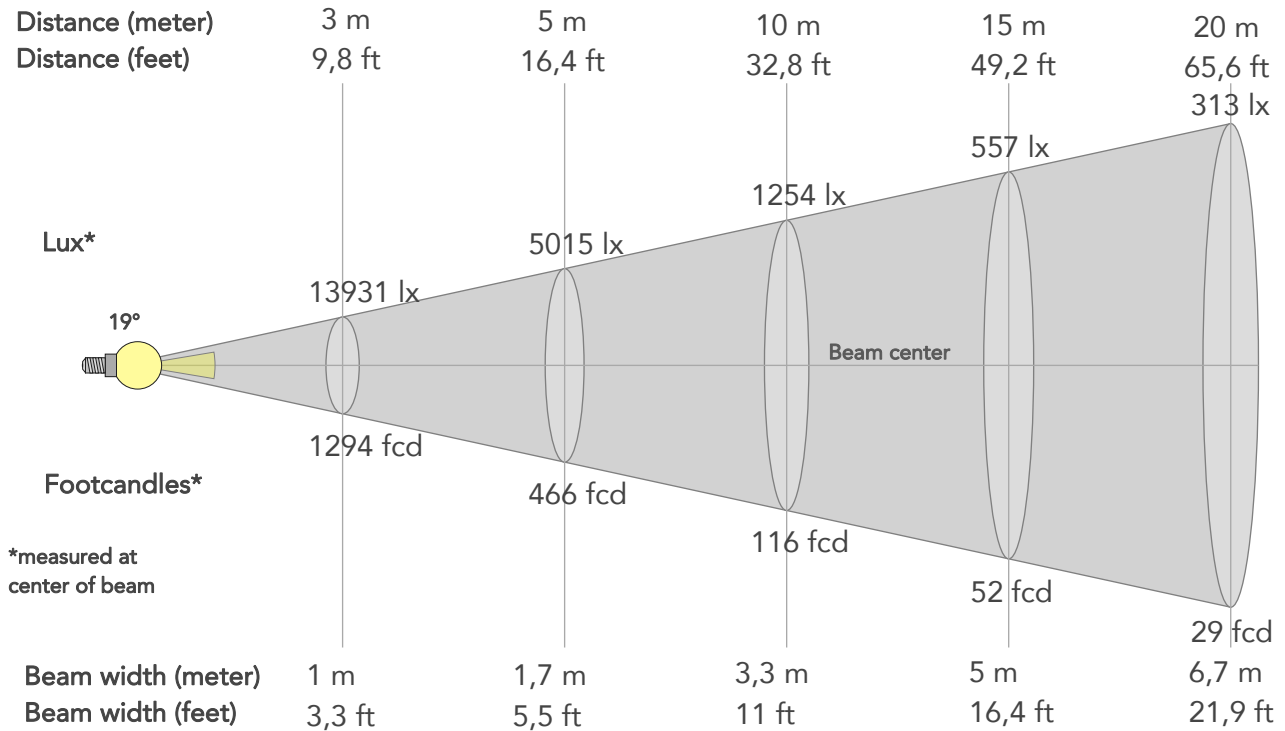

## BEAM INTENSITIES AND WIDTHS

Distance	1m	2m	3m	4m	5m	7,5m	10m	15m	20m	25m	30m	40m	50m
Distance	3,3ft	6,6ft	9,8ft	13,1ft	16,4ft	24,6ft	32,8ft	49,2ft	65,6ft	82ft	98,4ft	131,2ft	164ft
Lux	125375lx	31344lx	13931lx	7836lx	5015lx	2229lx	1254lx	557lx	313lx	201lx	139lx	78lx	50lx
Footcand.	11648fcd	2912fcd	1294fcd	728fcd	466fcd	207fcd	116fcd	52fcd	29fcd	19fcd	13fcd	7fcd	5fcd
Beam wid.	0,3m	0,7m	1m	1,3m	1,7m	2,5m	3,3m	5m	6,7m	8,4m	10m	13,4m	16,7m
Beam wid.	1,1ft	2,2ft	3,3ft	4,4ft	5,5ft	8,2ft	11ft	16,4ft	21,9ft	27,4ft	32,9ft	43,9ft	54,8ft

## LINEAR DISTRIBUTION DIAGRAM

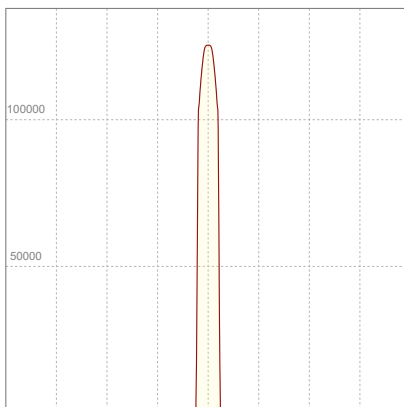

## ELECTRICAL SPECIFICATIONS

Input voltage	Input current	Input power	Power FC	Efficiency
225V	1,87A	408,6W	0,97	25lm/W

# ISO DIAGRAMS

## ISO CANDELA DIAGRAM

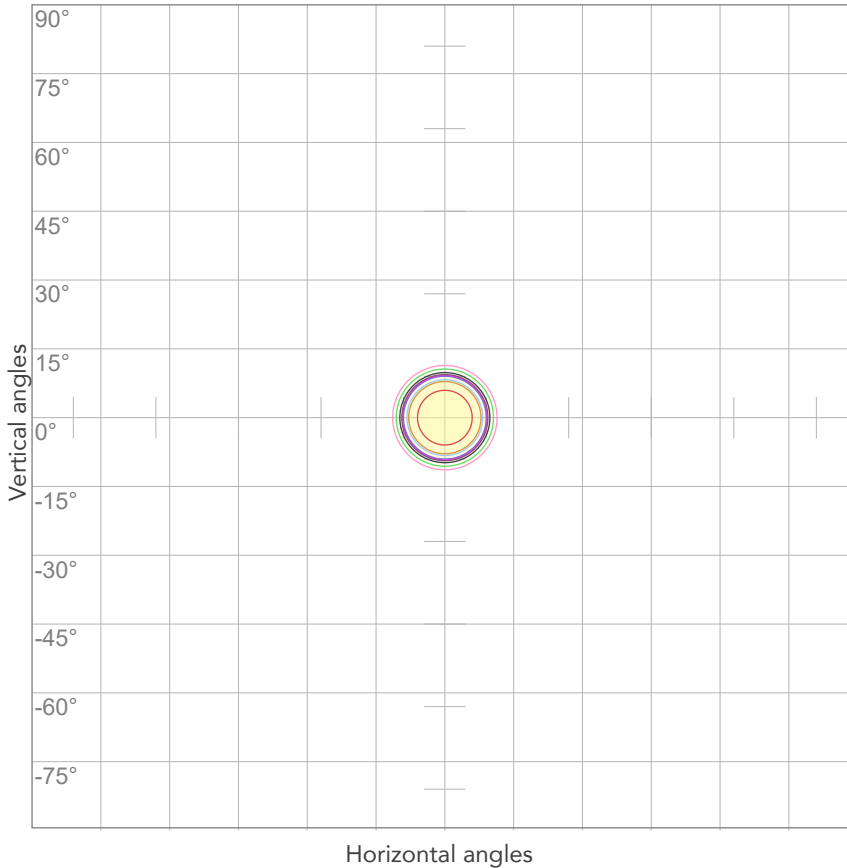

10%	12537 cd
20%	25075 cd
30%	37612 cd
40%	50150 cd
50%	62687 cd
60%	75225 cd
70%	87762 cd
80%	100300 cd

Conditions:

Number of c-planes: 2

Candela at center: 125375 cd

## ISO LUX DIAGRAM

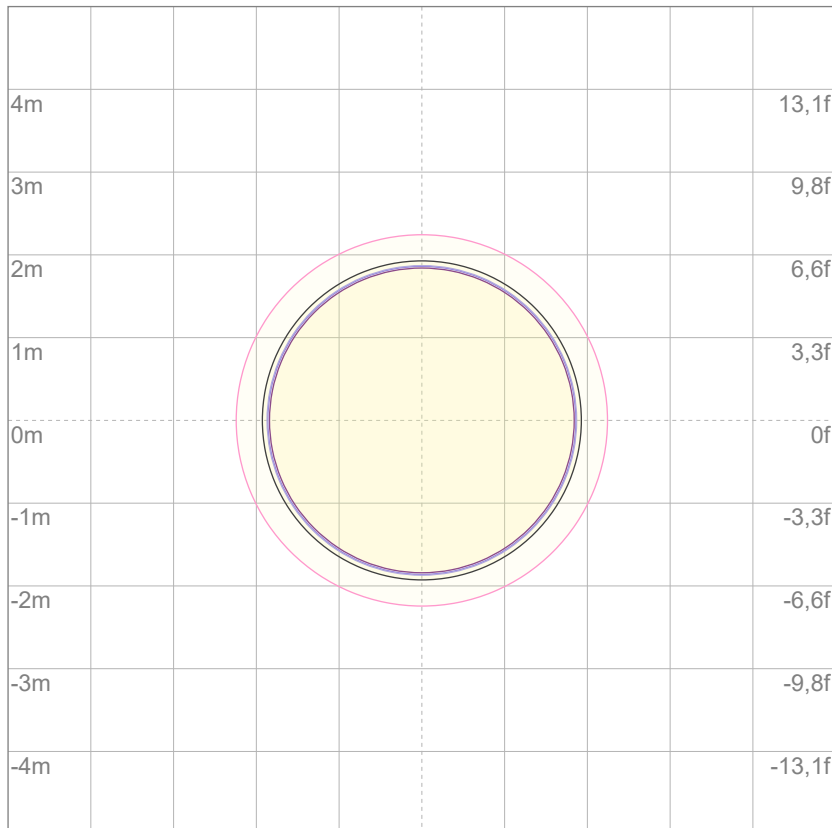

Mounting height: 10 meters (33 feet)

3%	37,6 lx
5%	62,7 lx
10%	125 lx
30%	376 lx
50%	627 lx

Conditions:

Number of c-planes: 2

Lux at center: 1254 lx

*Lux distribution on a surface when lamp is mounted at 10 meters from the surface.*



Total lumen output:

11428 lm

Peak candela output:

140932 cd

Light quality:

CRI: 97,8

Color temperature:

3215 K

PRODUCT NAME:

ECLFWHPVW

MEASUREMENT CONDITIONS:

Beam angle:

PRL19

Target:

3200K

Operator:

Giuseppe della Peruta

Date and time:

07/01/2026 12:30:33

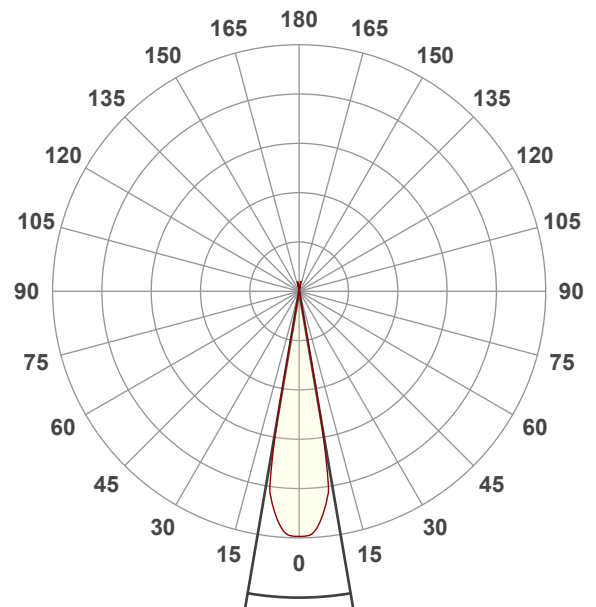

Beam angle 50%: 19,4°

Field angle 10%: 20,9°

Cut off angle 2.5%: 21,1°

Spectra

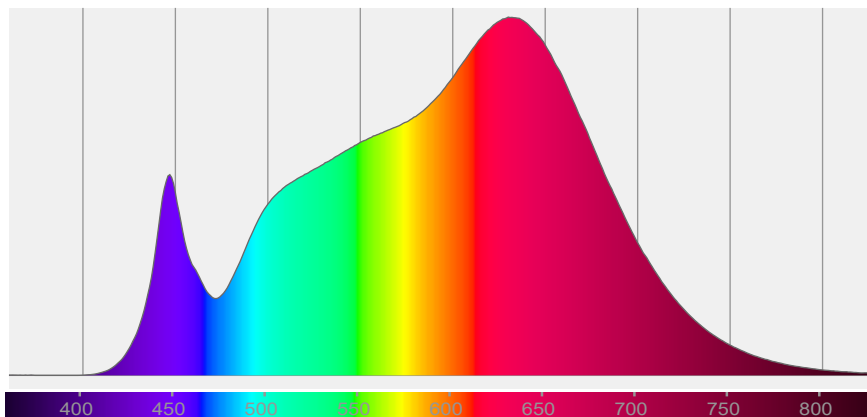

# COLOR DETAILS

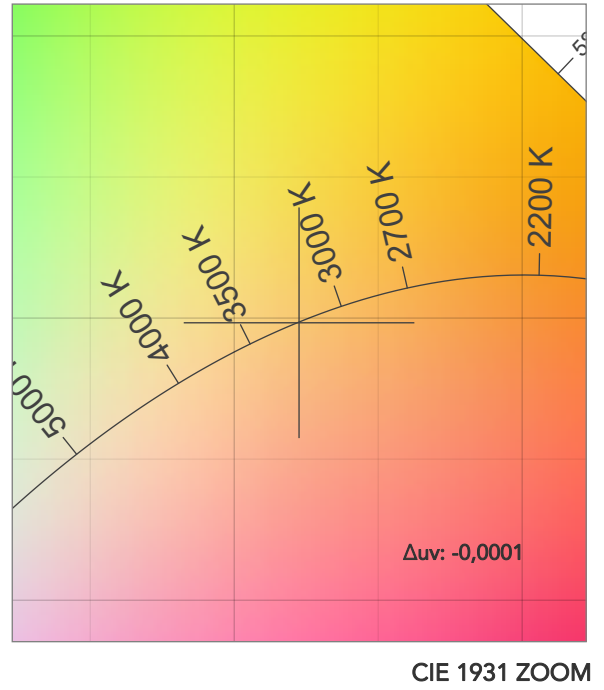
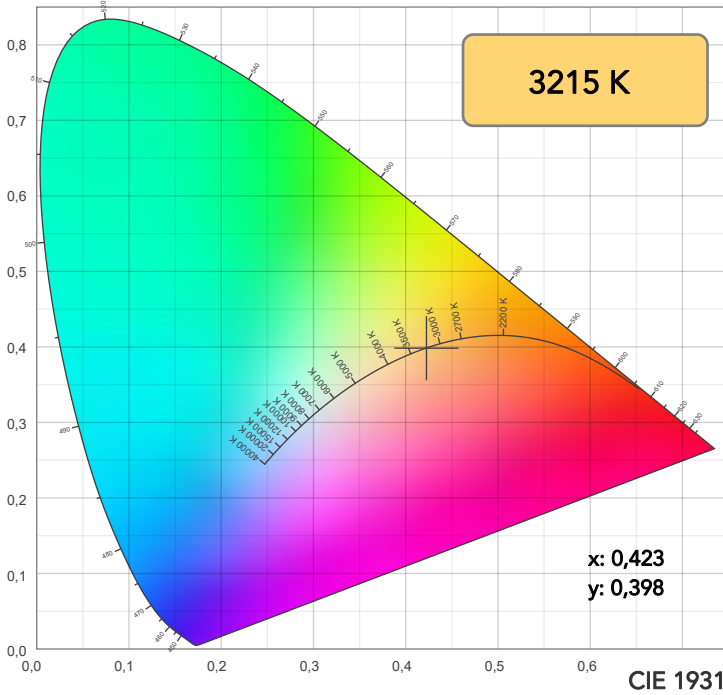

**TM30: 96,1**

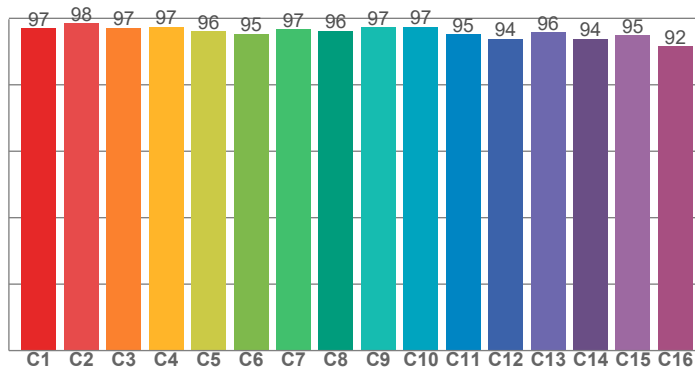

**CRI: 97,8 (R1-R8)**

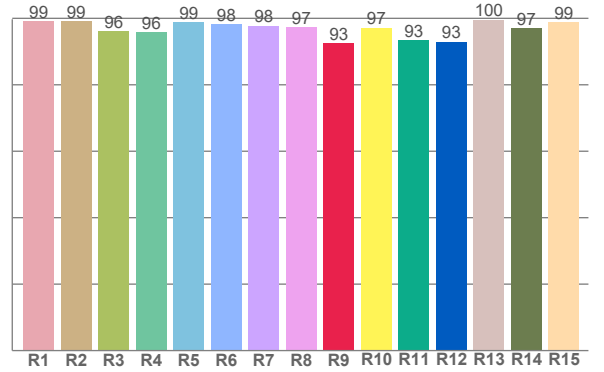

CRI R values, only R1-R8 are used to calculate final CRI value

R1	R2	R3	R4	R5	R6	R7	R8	R9	R10	R11	R12	R13	R14	R15
99,2	99,0	96,0	95,9	98,8	98,3	97,8	97,4	92,6	97,2	93,5	93,0	99,6	97,1	98,9

TM30 C values, 16 binned values out of total of 99 C values

C1	C2	C3	C4	C5	C6	C7	C8	C9	C10	C11	C12	C13	C14	C15	C16
96,9	98,4	97,1	97,5	96,0	95,3	96,7	96,3	97,2	97,5	95,1	93,8	95,8	93,8	95,0	91,5

CQS Q values

Q1	Q2	Q3	Q4	Q5	Q6	Q7	Q8	Q9	Q10	Q11	Q12	Q13	Q14	Q15
95,6	98,1	94,3	97,5	95,2	92,9	95,5	98,4	97,9	97,3	98,6	98,1	98,2	96,8	96,3

**CQS: 96,1**

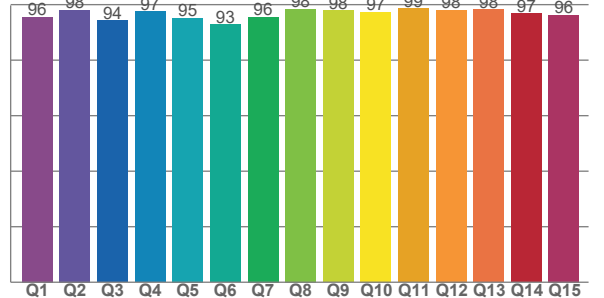

## COLOR PARAMETERS

Color temperature	Color rendering index	Red component	Color fidelity	Color gamut	Color quality scale	Television lighting index	Color coordinate cie 1931	Color coordinate cie 1931	Color deviation from black body
CCT	CRI	CRI R9	TM30 Rf	TM30 Rg	CQS	TLCI	x	y	Δuv
3215 K	97,8	92,6	96,1	102,5	96,1	98	0,423	0,398	-0,0001

# TM30 DETAILS

**Rf 96,1**  
Fidelity index Rf

**Rg 102,5**  
Gammut index

Hue Bin	R <sub>f</sub>	Graphic shifts (%)	
		Chroma	Hue
1	97	-1%	-1%
2	98	0%	0%
3	97	0%	1%
4	97	0%	1%
5	96	1%	2%
6	95	3%	1%
7	97	2%	-1%
8	96	2%	-1%
9	97	1%	-1%
10	97	0%	0%
11	95	1%	3%
12	94	3%	0%
13	96	2%	-2%
14	94	4%	-3%
15	95	1%	-3%
16	92	2%	-7%

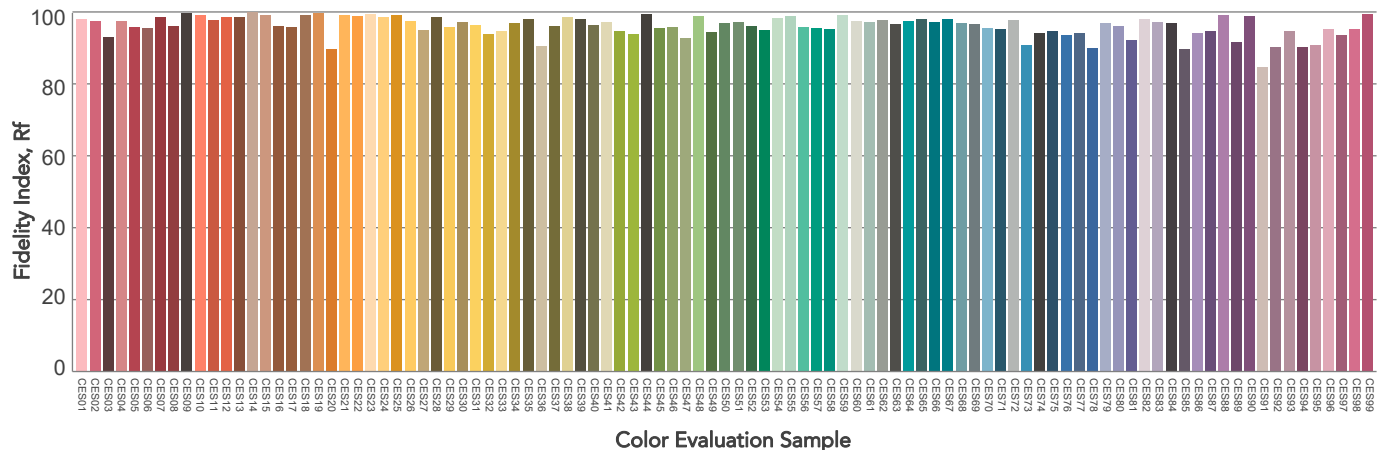
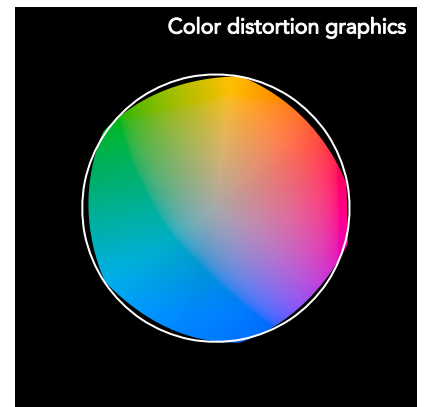
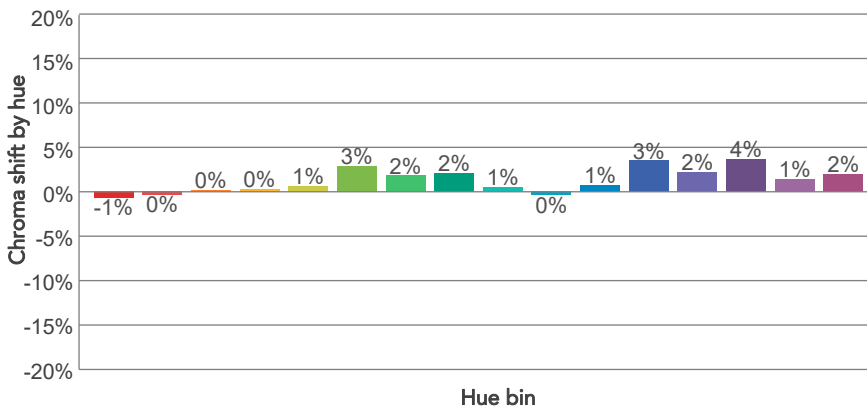
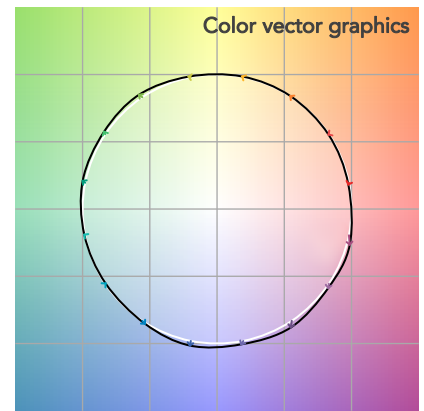
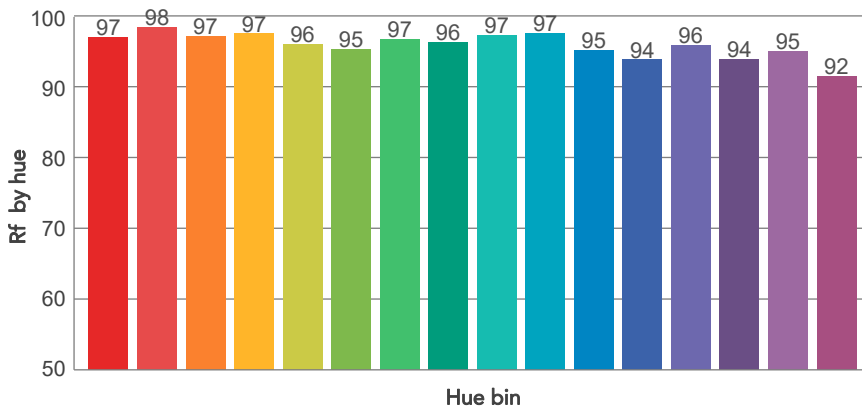
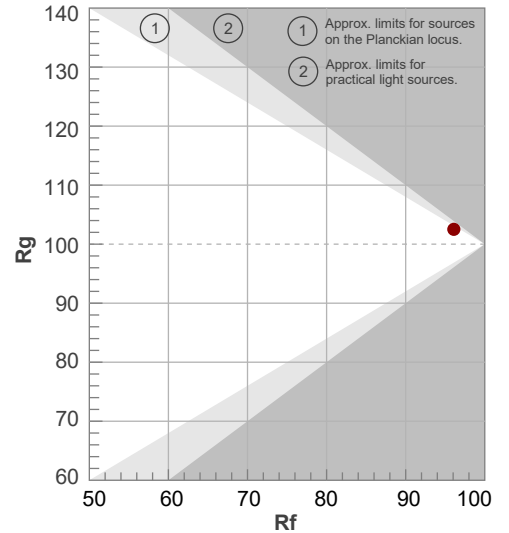

# BEAM DETAILS



Beam angle 50%	Field angle 10%	Cut off angle 2,5%	Intensity ratio in 120° cone	Intensity ratio in 90° cone
19,4°	20,9°	21,1°	100,0%	100,0%

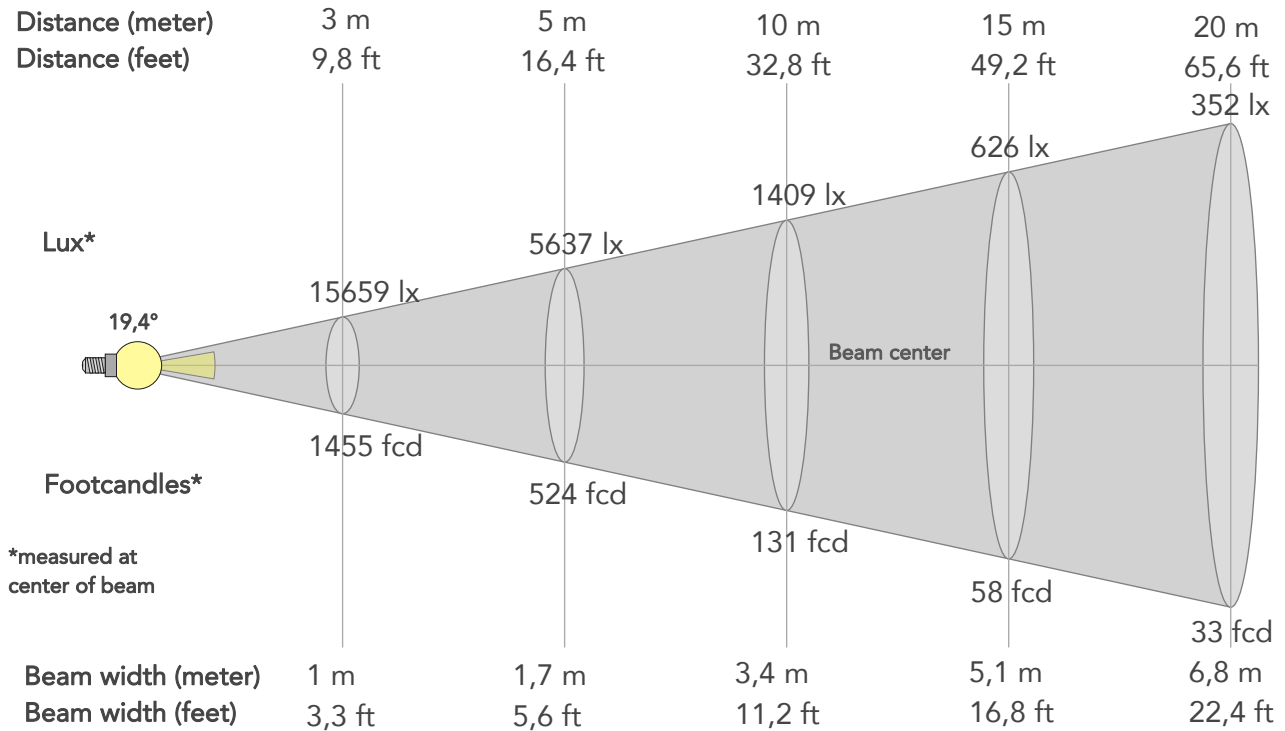

## BEAM INTENSITIES AND WIDTHS

Distance	1m	2m	3m	4m	5m	7,5m	10m	15m	20m	25m	30m	40m	50m
Distance	3,3ft	6,6ft	9,8ft	13,1ft	16,4ft	24,6ft	32,8ft	49,2ft	65,6ft	82ft	98,4ft	131,2ft	164ft
Lux	140932lx	35233lx	15659lx	8808lx	5637lx	2505lx	1409lx	626lx	352lx	225lx	157lx	88lx	56lx
Footcand.	13093fcd	3273fcd	1455fcd	818fcd	524fcd	233fcd	131fcd	58fcd	33fcd	21fcd	15fcd	8fcd	5fcd
Beam wid.	0,3m	0,7m	1m	1,4m	1,7m	2,6m	3,4m	5,1m	6,8m	8,5m	10,2m	13,6m	17,1m
Beam wid.	1,1ft	2,3ft	3,3ft	4,5ft	5,6ft	8,4ft	11,2ft	16,8ft	22,4ft	28ft	33,6ft	44,7ft	55,9ft

## LINEAR DISTRIBUTION DIAGRAM

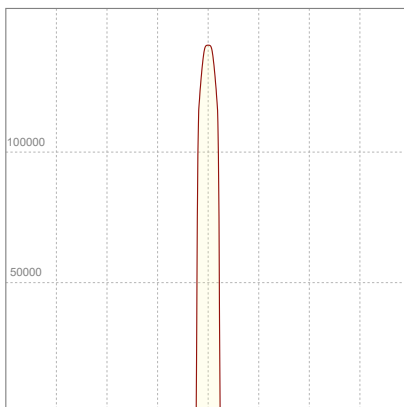

## ELECTRICAL SPECIFICATIONS

Input voltage	Input current	Input power	Power FC	Efficiency
225V	2,00A	438,2W	0,97	26lm/W

# ISO DIAGRAMS

## ISO CANDELA DIAGRAM

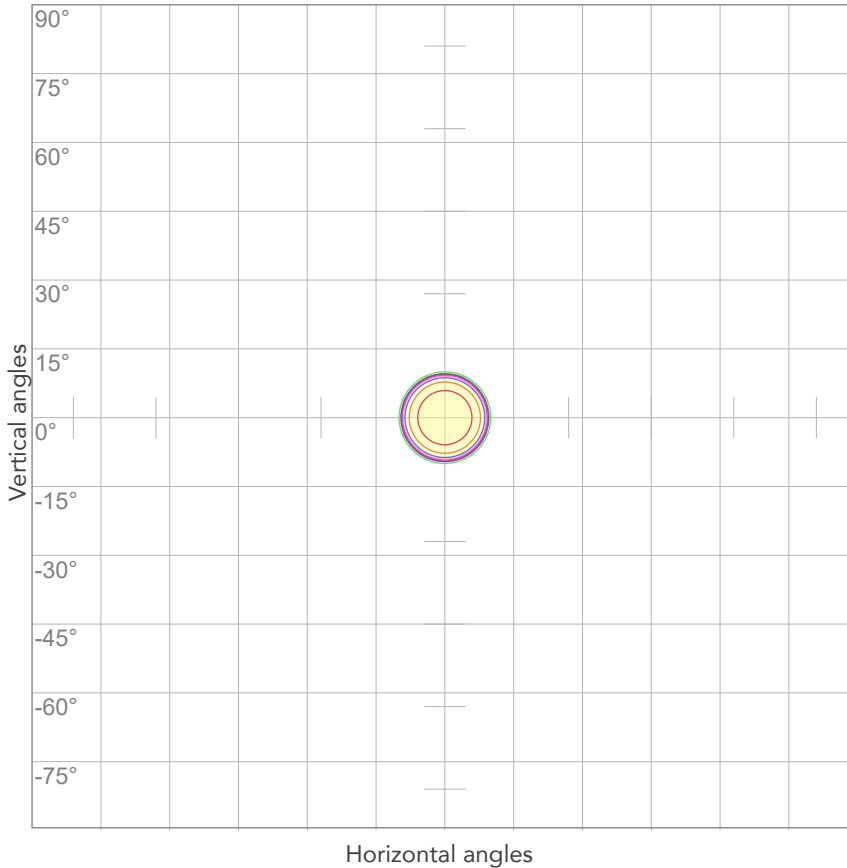

10%	14093 cd
20%	28186 cd
30%	42280 cd
40%	56373 cd
50%	70466 cd
60%	84559 cd
70%	98652 cd
80%	112746 cd

Conditions:

Number of c-planes: 2

Candela at center: 140932 cd

## ISO LUX DIAGRAM

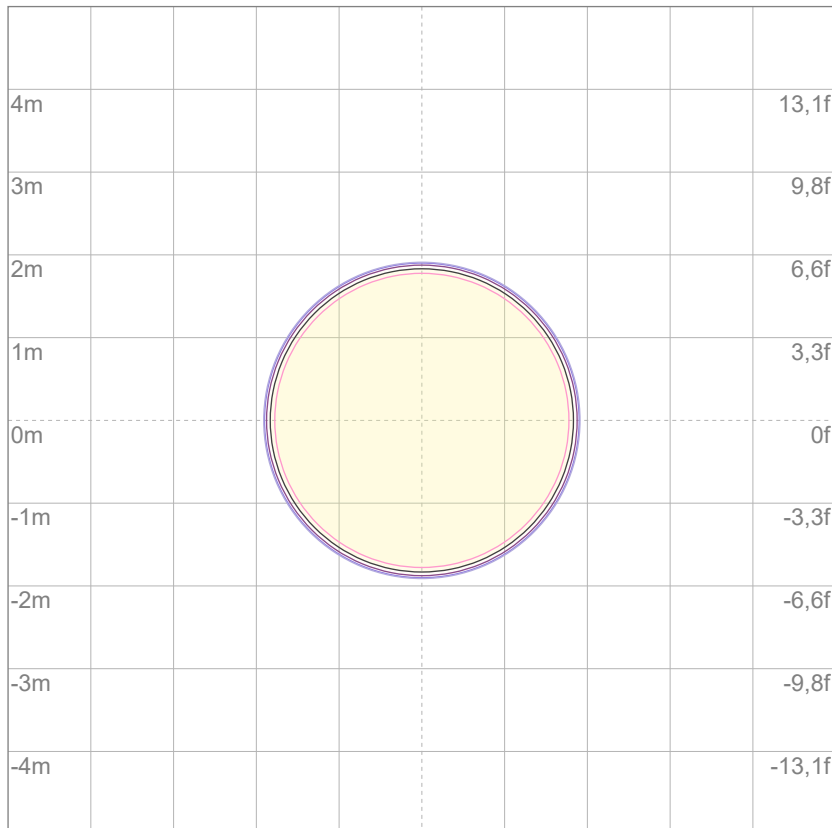

3%	42,3 lx
5%	70,5 lx
10%	141 lx
30%	423 lx
50%	705 lx

Conditions:

Number of c-planes: 2

Lux at center: 1409 lx

*Lux distribution on a surface when lamp is mounted at 10 meters from the surface.*



Total lumen output:

12235 lm

Peak candela output:

151215 cd

Light quality:

CRI: 98,0

Color temperature:

4025 K

PRODUCT NAME:

ECLFWHPVW

MEASURAMENT CONDITIONS:

Beam angle:

PRL19

Target:

4000K

Operator:

Giuseppe della Peruta

Date and time:

07/01/2026 12:25:51

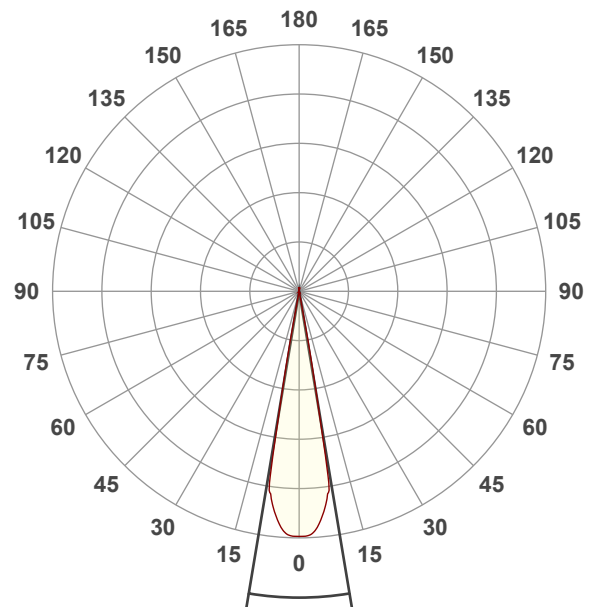

Beam angle 50%: 18,9°

Field angle 10%: 21,2°

Cut off angle 2.5%: 21,7°

Spectra

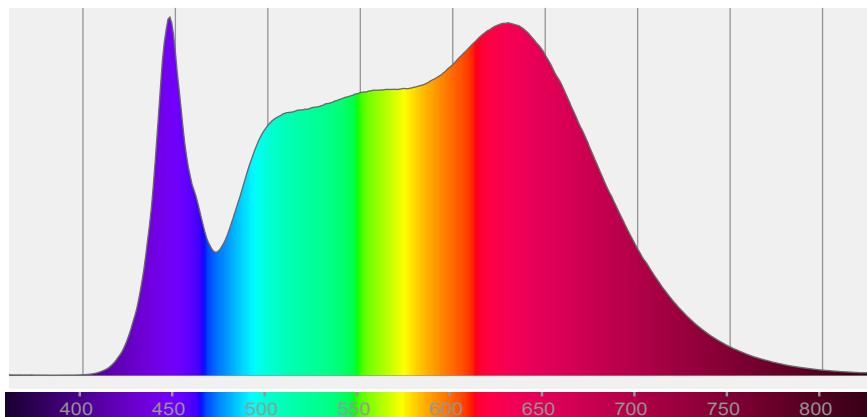

# COLOR DETAILS

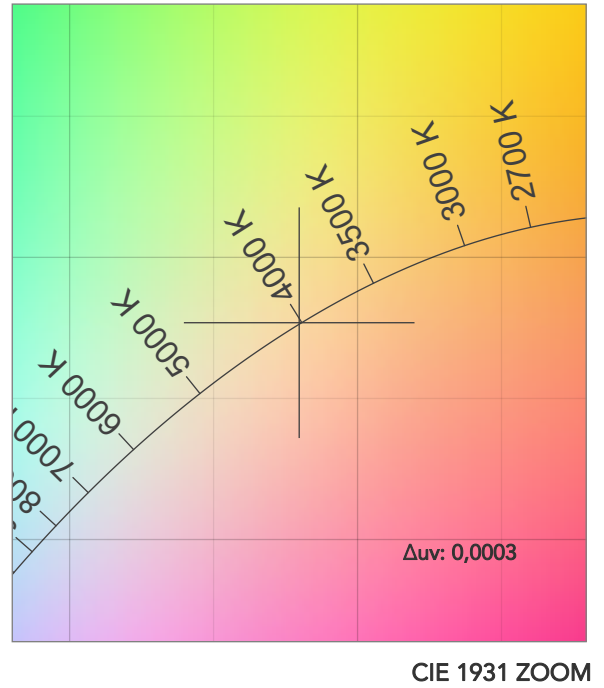
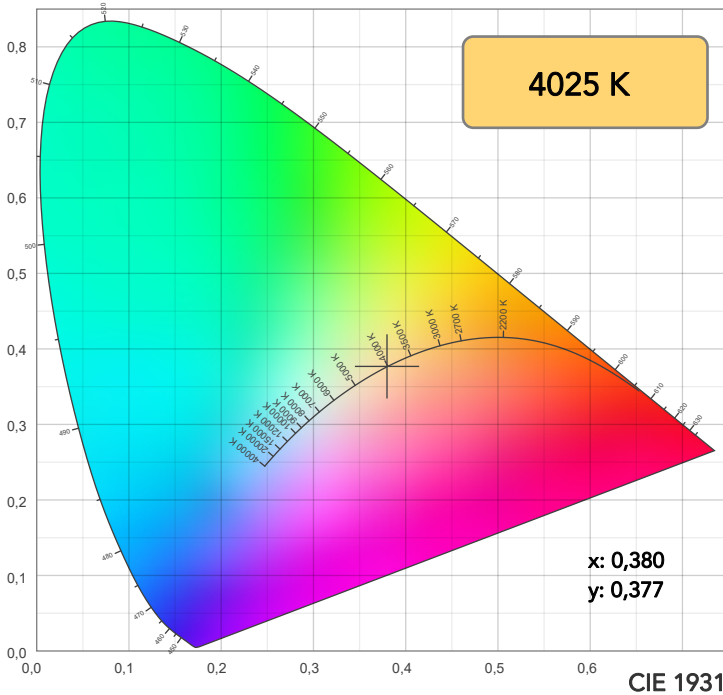

**TM30: 96,2**

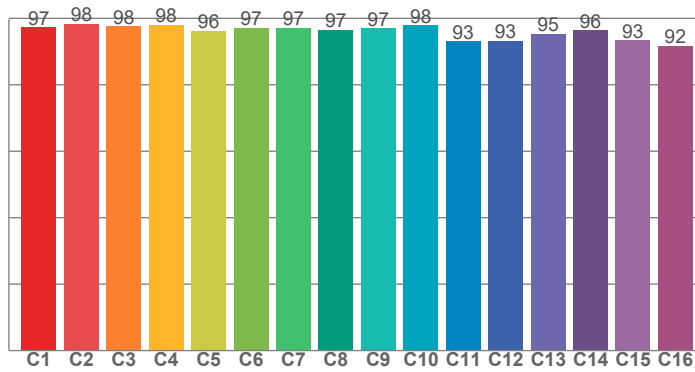

**CRI: 98,0 (R1-R8)**

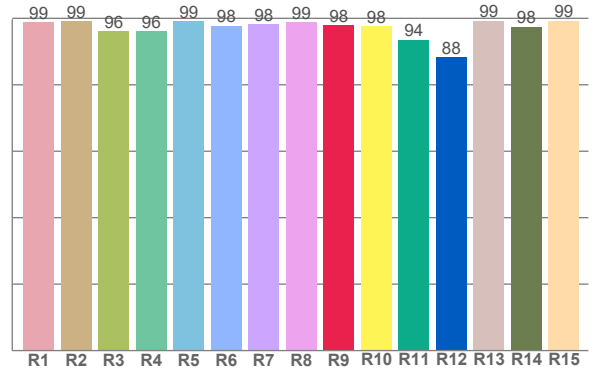

CRI R values, only R1-R8 are used to calculate final CRI value

R1	R2	R3	R4	R5	R6	R7	R8	R9	R10	R11	R12	R13	R14	R15
98,8	99,1	96,2	96,1	99,1	97,8	98,1	98,9	98,1	97,8	93,5	88,4	99,3	97,5	99,3

TM30 C values, 16 binned values out of total of 99 C values

C1	C2	C3	C4	C5	C6	C7	C8	C9	C10	C11	C12	C13	C14	C15	C16
97,4	98,4	97,6	98,1	96,2	97,2	97,1	96,6	96,9	97,9	93,1	93,2	95,4	96,4	93,4	91,8

CQS Q values

Q1	Q2	Q3	Q4	Q5	Q6	Q7	Q8	Q9	Q10	Q11	Q12	Q13	Q14	Q15
98,6	99,7	94,5	97,6	97,9	95,9	98,1	99,4	99,0	99,1	99,3	98,7	98,8	99,4	99,1

**CQS: 97,8**

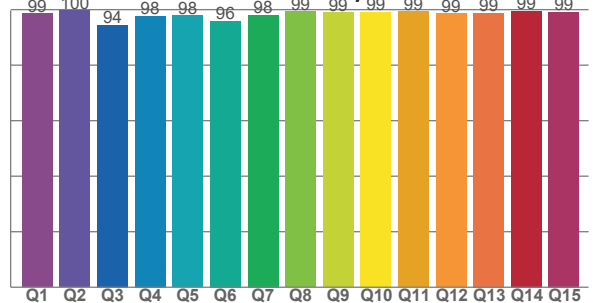

## COLOR PARAMETERS

Color temperature	Color rendering index	Red component	Color fidelity	Color gamut	Color quality scale	Television lighting index	Color coordinate cie 1931	Color coordinate cie 1931	Color deviation from black body
CCT	CRI	CRI R9	TM30 Rf	TM30 Rg	CQS	TLCI	x	y	Δuv
4025 K	98,0	98,1	96,2	102,0	97,8	98	0,380	0,377	0,0003

# TM30 DETAILS

**Rf 96,2**  
Fidelity index Rf

**Rg 102,0**  
Gammut index

Hue Bin	R <sub>f</sub>	Graphic shifts (%)	
		Chroma	Hue
1	97	0%	-1%
2	98	0%	-1%
3	98	0%	1%
4	98	-1%	0%
5	96	-1%	1%
6	97	2%	1%
7	97	1%	1%
8	97	1%	1%
9	97	0%	1%
10	98	0%	1%
11	93	2%	4%
12	93	3%	2%
13	95	3%	-1%
14	96	2%	0%
15	93	3%	-3%
16	92	2%	-5%

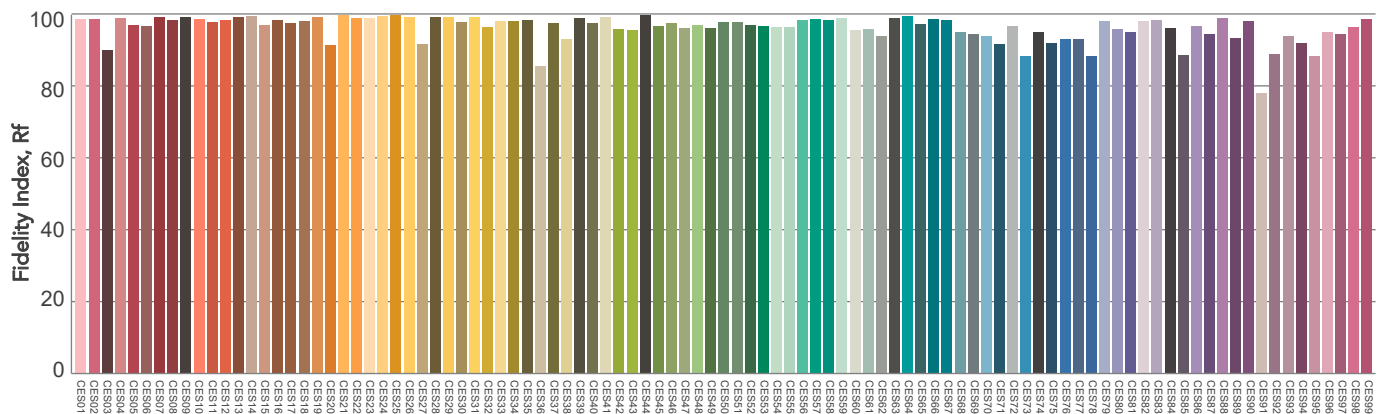
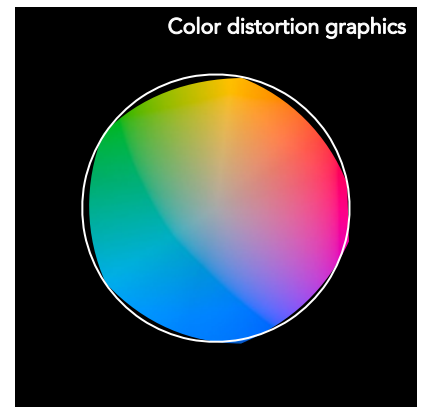
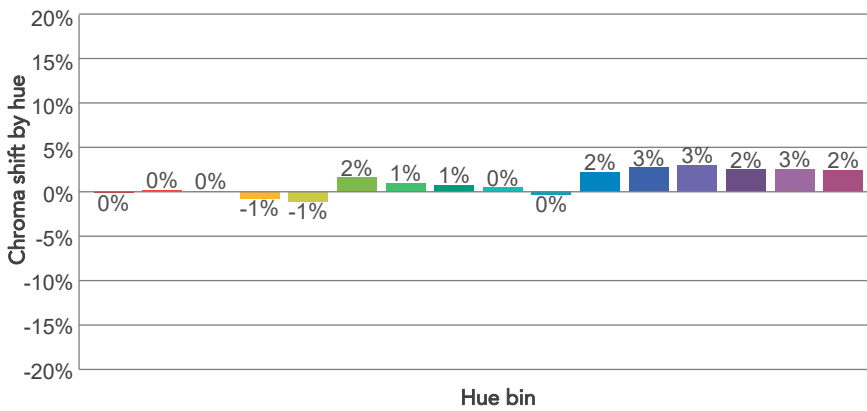
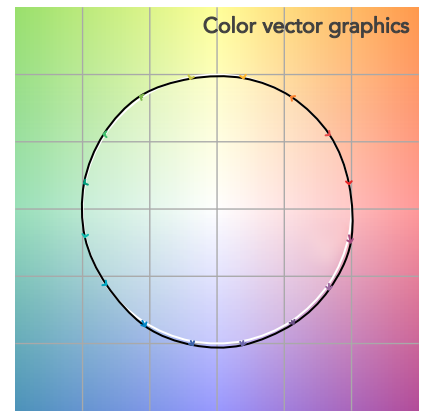
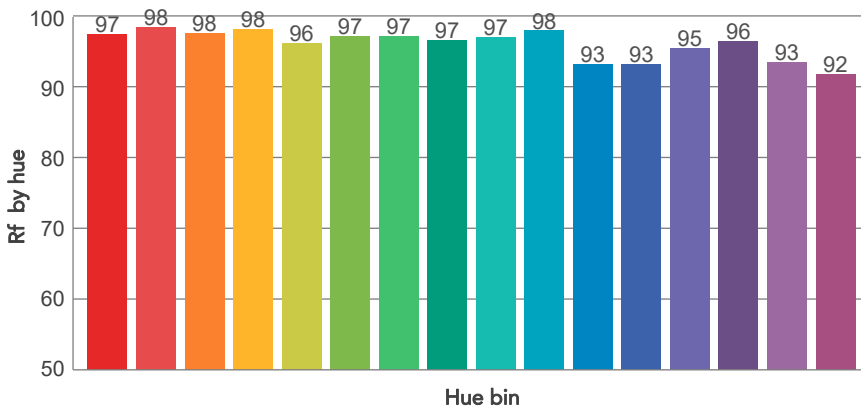
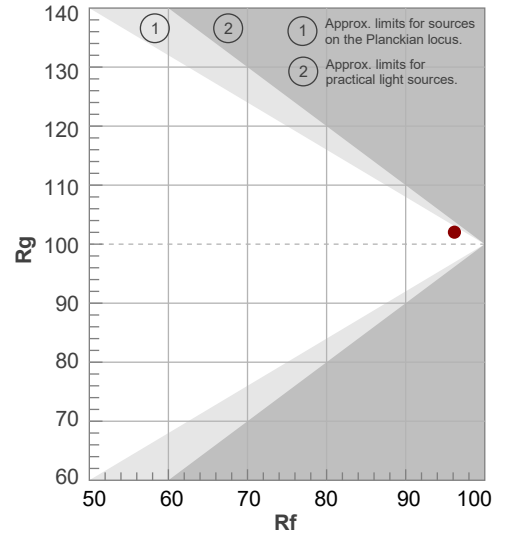

Color Evaluation Sample

# BEAM DETAILS



Beam angle 50%	Field angle 10%	Cut off angle 2,5%	Intensity ratio in 120° cone	Intensity ratio in 90° cone
18,9°	21,2°	21,7°	100,0%	100,0%

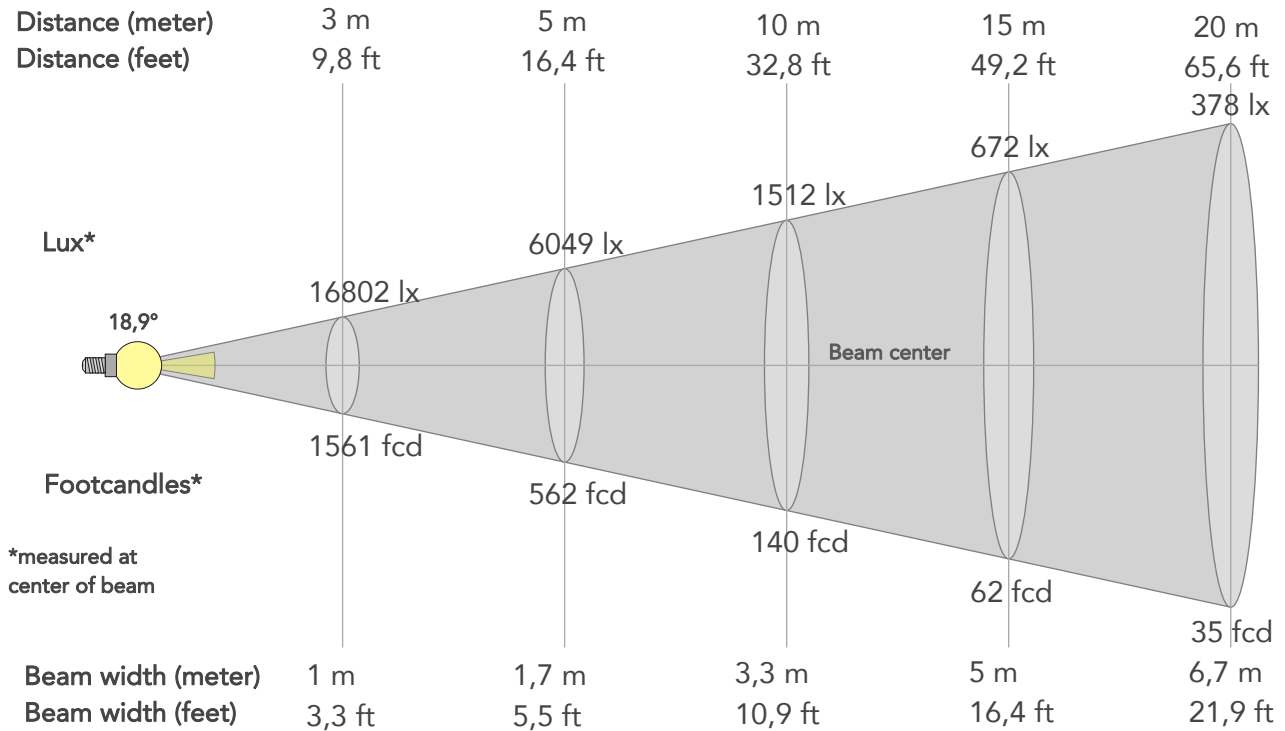

## BEAM INTENSITIES AND WIDTHS

Distance	1m	2m	3m	4m	5m	7,5m	10m	15m	20m	25m	30m	40m	50m
Distance	3,3ft	6,6ft	9,8ft	13,1ft	16,4ft	24,6ft	32,8ft	49,2ft	65,6ft	82ft	98,4ft	131,2ft	164ft
Lux	151215lx	37804lx	16802lx	9451lx	6049lx	2688lx	1512lx	672lx	378lx	242lx	168lx	95lx	60lx
Footcand.	14048fcd	3512fcd	1561fcd	878fcd	562fcd	250fcd	140fcd	62fcd	35fcd	22fcd	16fcd	9fcd	6fcd
Beam wid.	0,3m	0,7m	1m	1,3m	1,7m	2,5m	3,3m	5m	6,7m	8,3m	10m	13,3m	16,7m
Beam wid.	1,1ft	2,2ft	3,3ft	4,4ft	5,5ft	8,2ft	10,9ft	16,4ft	21,9ft	27,3ft	32,8ft	43,8ft	54,7ft

## LINEAR DISTRIBUTION DIAGRAM

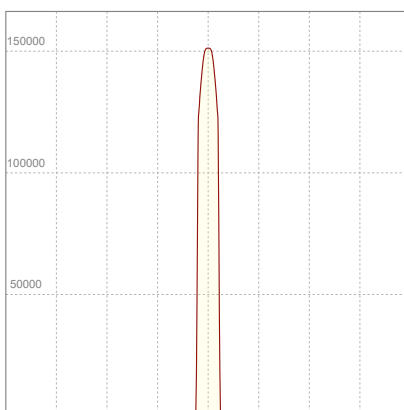

## ELECTRICAL SPECIFICATIONS

Input voltage	Input current	Input power	Power FC	Efficiency
225V	2,00A	437,3W	0,97	28lm/W

# ISO DIAGRAMS

## ISO CANDELA DIAGRAM

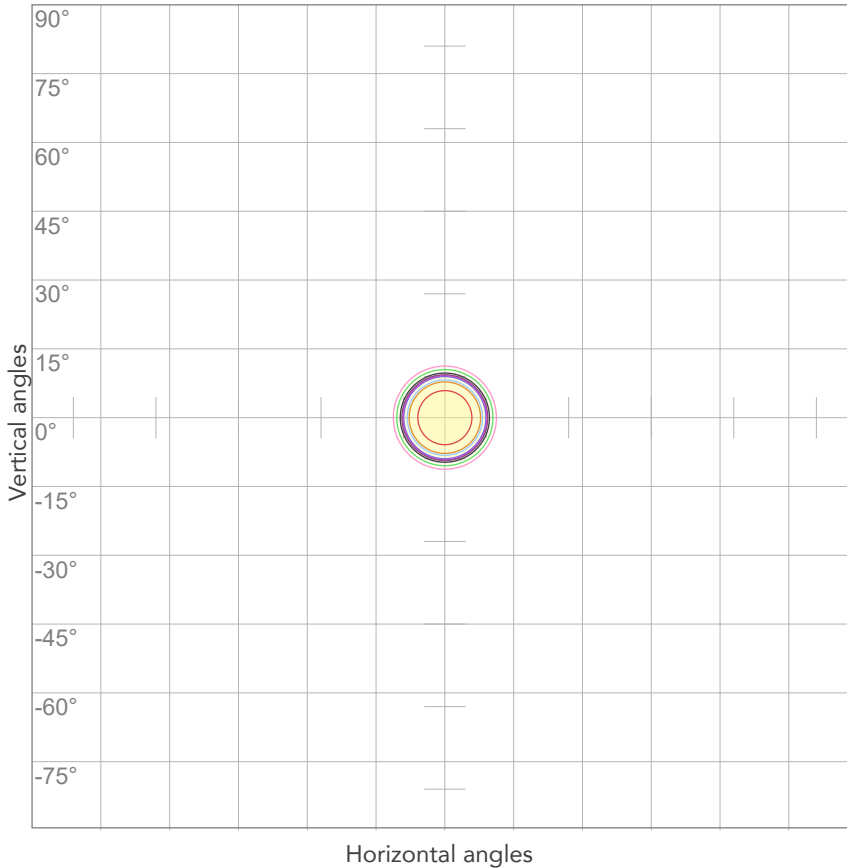

10%	15122 cd
20%	30243 cd
30%	45365 cd
40%	60486 cd
50%	75608 cd
60%	90729 cd
70%	105851 cd
80%	120972 cd

Conditions:

Number of c-planes: 2

Candela at center: 151215 cd

## ISO LUX DIAGRAM

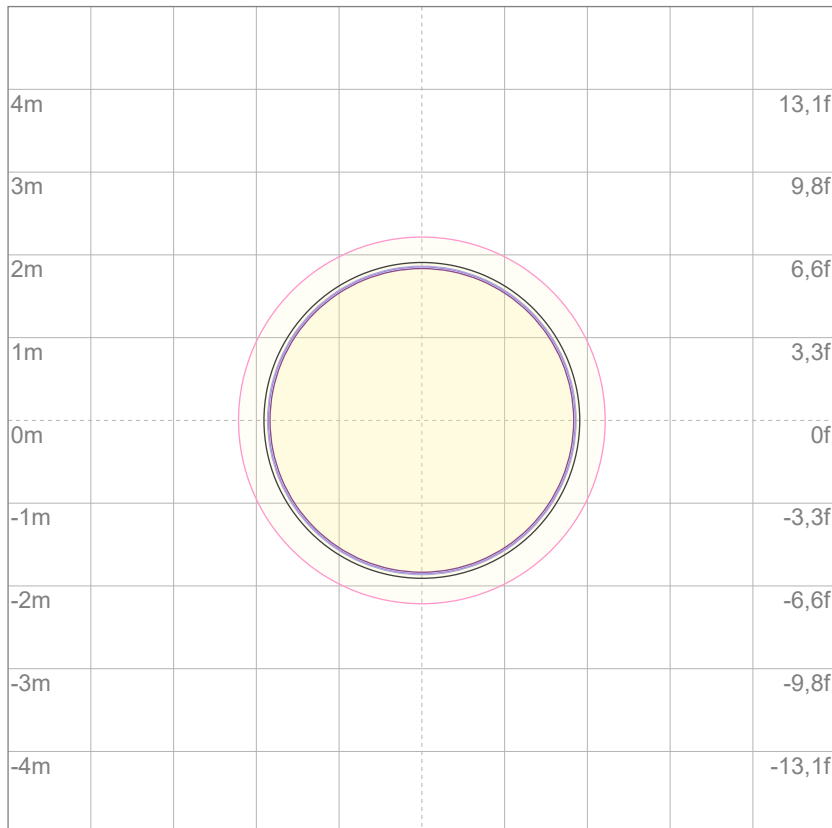

Mounting height: 10 meters (33 feet)

3%	45,4 lx
5%	75,6 lx
10%	151 lx
30%	454 lx
50%	756 lx

Conditions:

Number of c-planes: 2

Lux at center: 1512 lx

*Lux distribution on a surface when lamp is mounted at 10 meters from the surface.*



Total lumen output:

13419 lm

Peak candela output:

166750 cd

Light quality:

CRI: 96,3

Color temperature:

5586 K

PRODUCT NAME:

ECLFWHPVW

MEASURAMENT CONDITIONS:

Beam angle:

PRL19

Target:

5600K

Operator:

Giuseppe della Peruta

Date and time:

07/01/2026 12:20:51

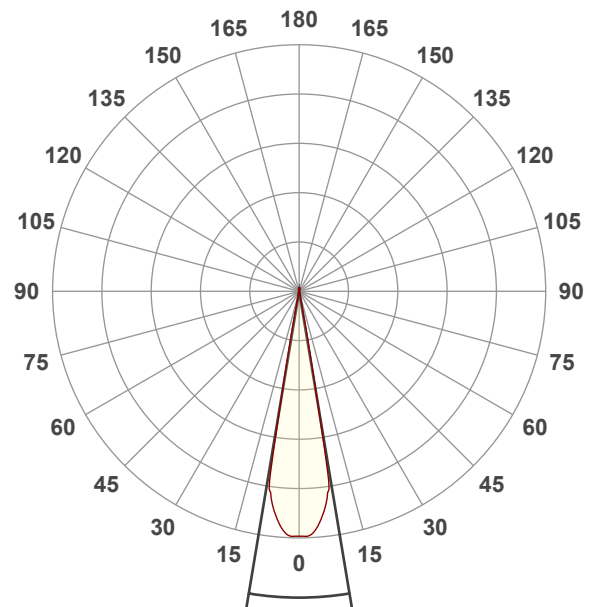

Beam angle 50%: 18,9°

Field angle 10%: 21,2°

Cut off angle 2.5%: 21,8°

Spectra

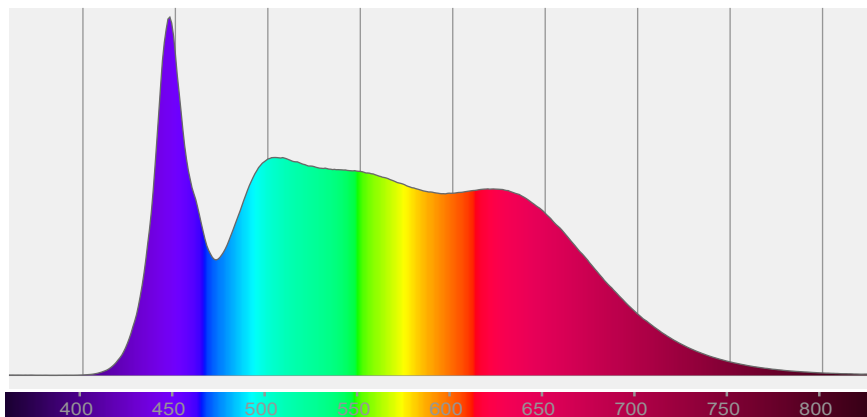

# COLOR DETAILS

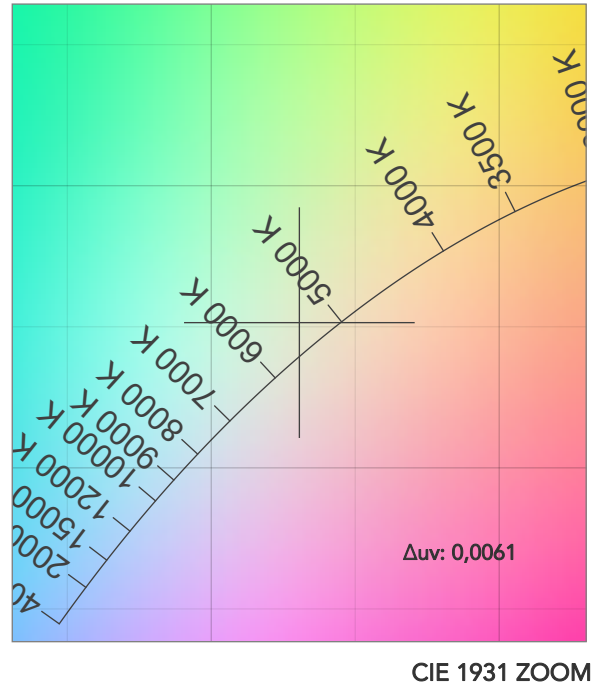
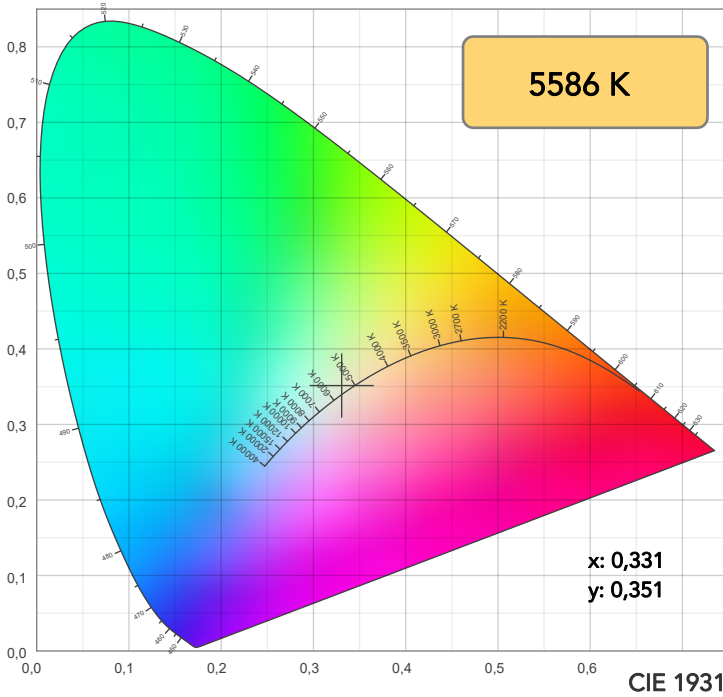

**TM30: 95,5**

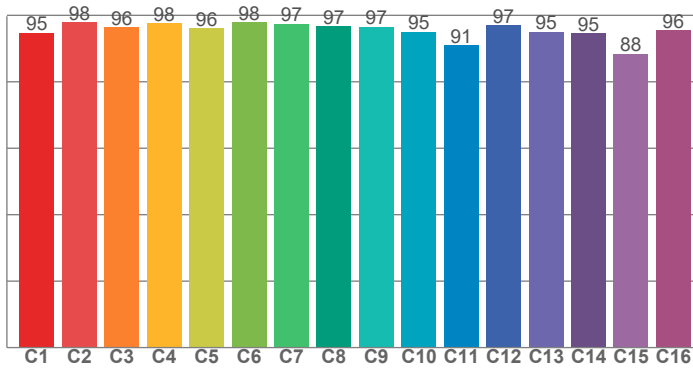

**CRI: 96,3 (R1-R8)**

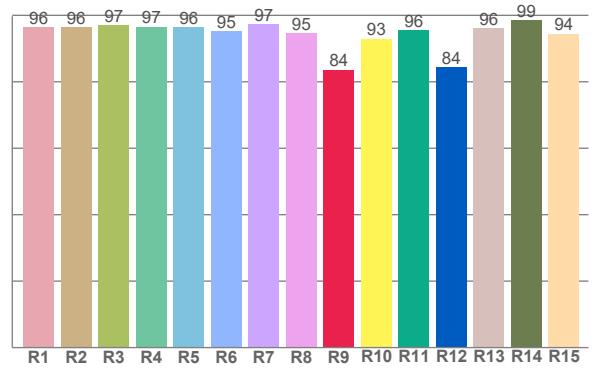

CRI R values, only R1-R8 are used to calculate final CRI value

R1	R2	R3	R4	R5	R6	R7	R8	R9	R10	R11	R12	R13	R14	R15
96,4	96,4	97,0	96,6	96,4	95,2	97,3	94,7	83,6	93,0	95,5	84,5	96,2	98,6	94,5

TM30 C values, 16 binned values out of total of 99 C values

C1	C2	C3	C4	C5	C6	C7	C8	C9	C10	C11	C12	C13	C14	C15	C16
94,8	97,9	96,5	97,6	96,1	97,9	97,5	96,7	96,5	95,1	91,0	97,1	95,0	94,6	88,4	95,6

CQS Q values

Q1	Q2	Q3	Q4	Q5	Q6	Q7	Q8	Q9	Q10	Q11	Q12	Q13	Q14	Q15
96,6	99,5	93,5	95,9	97,6	96,3	97,4	99,1	99,7	98,5	98,7	98,4	98,4	95,6	96,0

**CQS: 96,9**

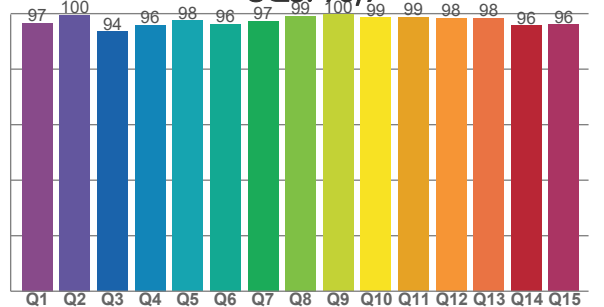

## COLOR PARAMETERS

Color temperature	Color rendering index	Red component	Color fidelity	Color gamut	Color quality scale	Television lighting index	Color coordinate cie 1931	Color coordinate cie 1931	Color deviation from black body
CCT	CRI	CRI R9	TM30 Rf	TM30 Rg	CQS	TLCI	x	y	$\Delta uv$
5586 K	96,3	83,6	95,5	100,6	96,9	99	0,331	0,351	0,0061

# TM30 DETAILS

**Rf 95,5**  
Fidelity index Rf

**Rg 100,6**  
Gammut index

Hue Bin	R <sub>f</sub>	Graphic shifts (%)	
		Chroma	Hue
1	95	-2%	-1%
2	98	-1%	0%
3	96	-1%	1%
4	98	-1%	0%
5	96	-1%	0%
6	98	1%	0%
7	97	0%	0%
8	97	-1%	0%
9	97	-1%	2%
10	95	-1%	3%
11	91	2%	5%
12	97	2%	1%
13	95	3%	-2%
14	95	2%	-2%
15	88	6%	-9%
16	96	0%	-2%

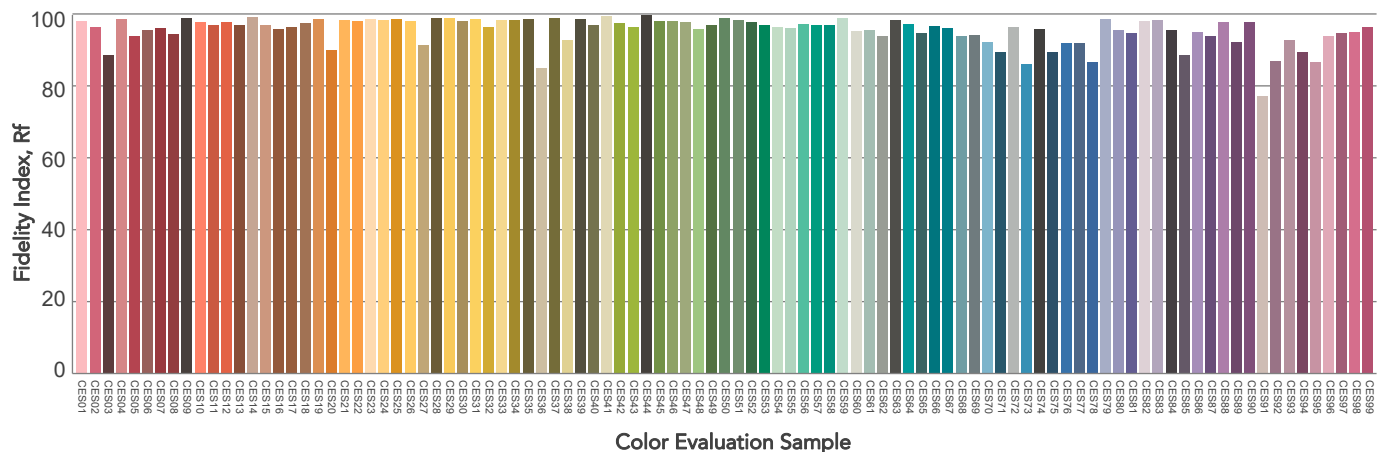
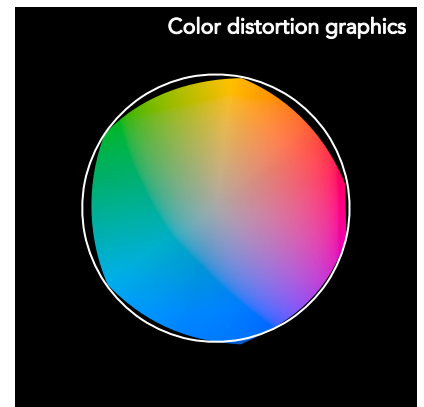
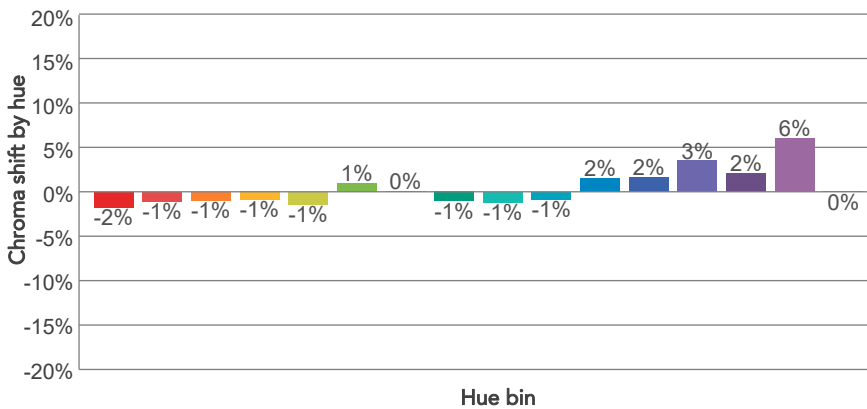
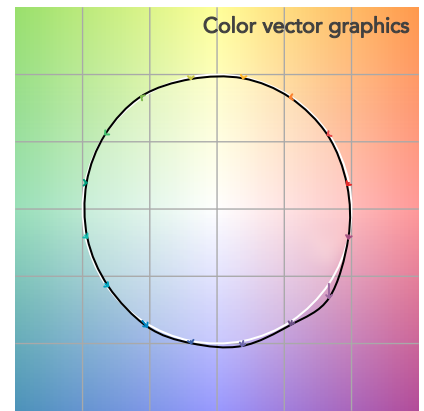
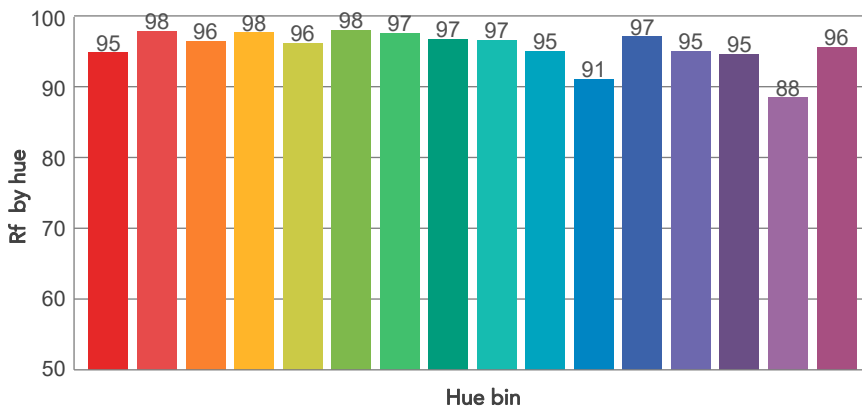
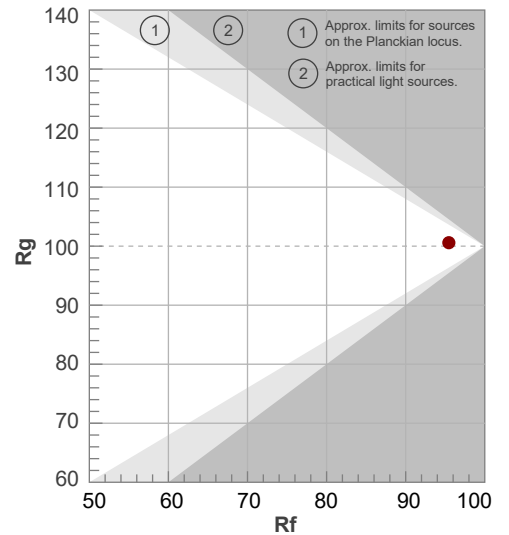

# BEAM DETAILS



Beam angle 50%	Field angle 10%	Cut off angle 2,5%	Intensity ratio in 120° cone	Intensity ratio in 90° cone
18,9°	21,2°	21,8°	100,0%	100,0%

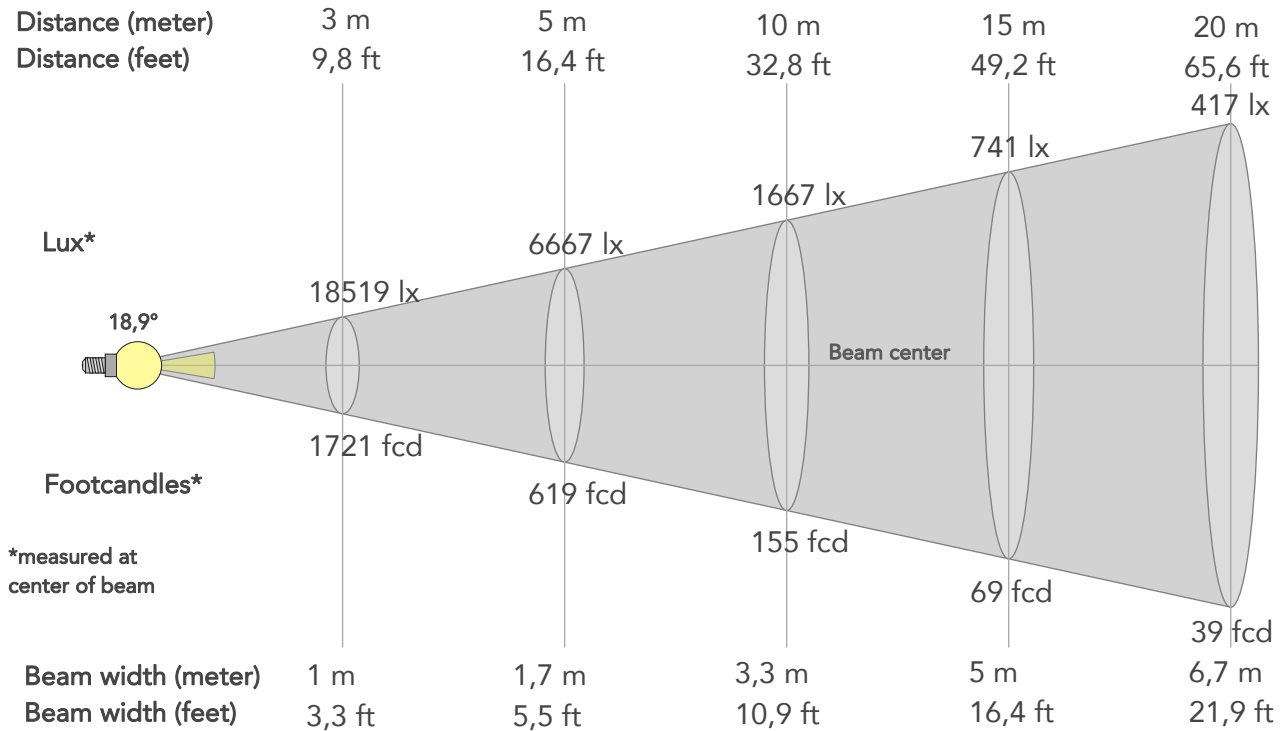

## BEAM INTENSITIES AND WIDTHS

Distance	1m	2m	3m	4m	5m	7,5m	10m	15m	20m	25m	30m	40m	50m
Distance	3,3ft	6,6ft	9,8ft	13,1ft	16,4ft	24,6ft	32,8ft	49,2ft	65,6ft	82ft	98,4ft	131,2ft	164ft
Lux	166674lx	41669lx	18519lx	10417lx	6667lx	2963lx	1667lx	741lx	417lx	267lx	185lx	104lx	67lx
Footcand.	15485fcd	3871fcd	1721fcd	968fcd	619fcd	275fcd	155fcd	69fcd	39fcd	25fcd	17fcd	10fcd	6fcd
Beam wid.	0,3m	0,7m	1m	1,3m	1,7m	2,5m	3,3m	5m	6,7m	8,3m	10m	13,3m	16,7m
Beam wid.	1,1ft	2,2ft	3,3ft	4,4ft	5,5ft	8,2ft	10,9ft	16,4ft	21,9ft	27,3ft	32,8ft	43,7ft	54,7ft

## LINEAR DISTRIBUTION DIAGRAM

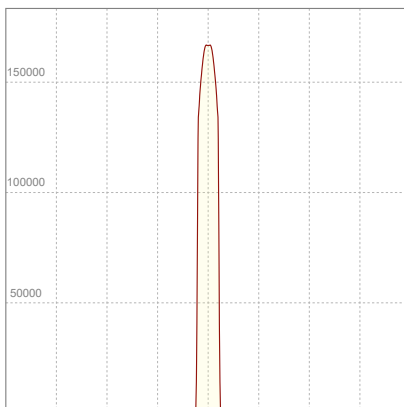

## ELECTRICAL SPECIFICATIONS

Input voltage	Input current	Input power	Power FC	Efficiency
225V	2,01A	440,1W	0,97	30lm/W

# ISO DIAGRAMS

## ISO CANDELA DIAGRAM

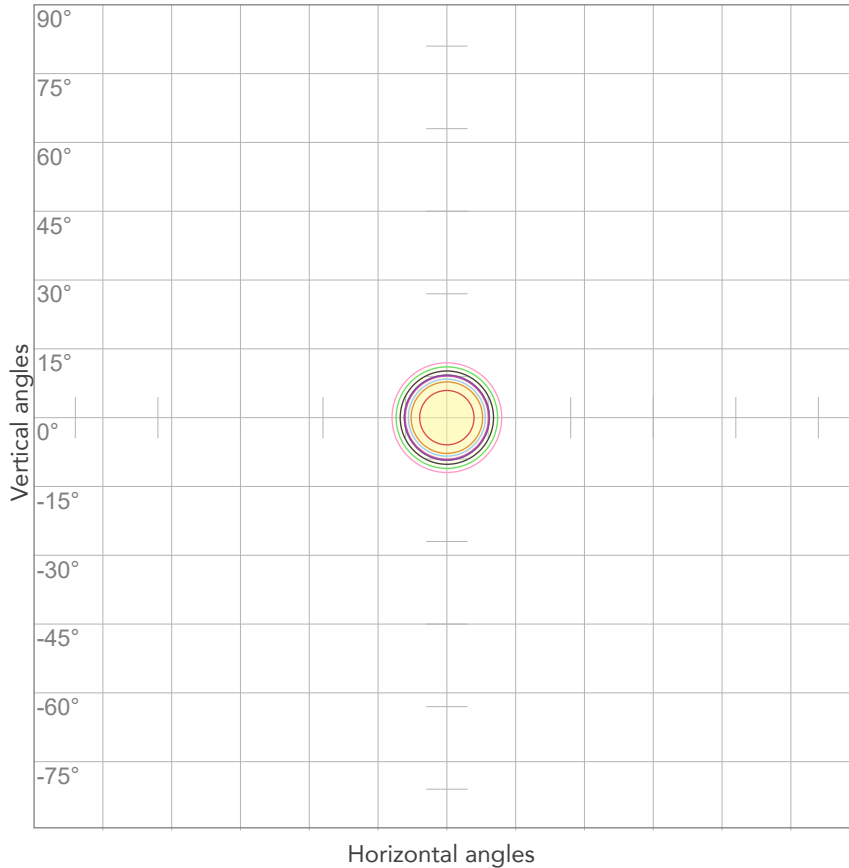

10%	16667 cd
20%	33335 cd
30%	50002 cd
40%	66670 cd
50%	83337 cd
60%	100004 cd
70%	116672 cd
80%	133339 cd

Conditions:

Number of c-planes: 2

Candela at center: 166674 cd

## ISO LUX DIAGRAM

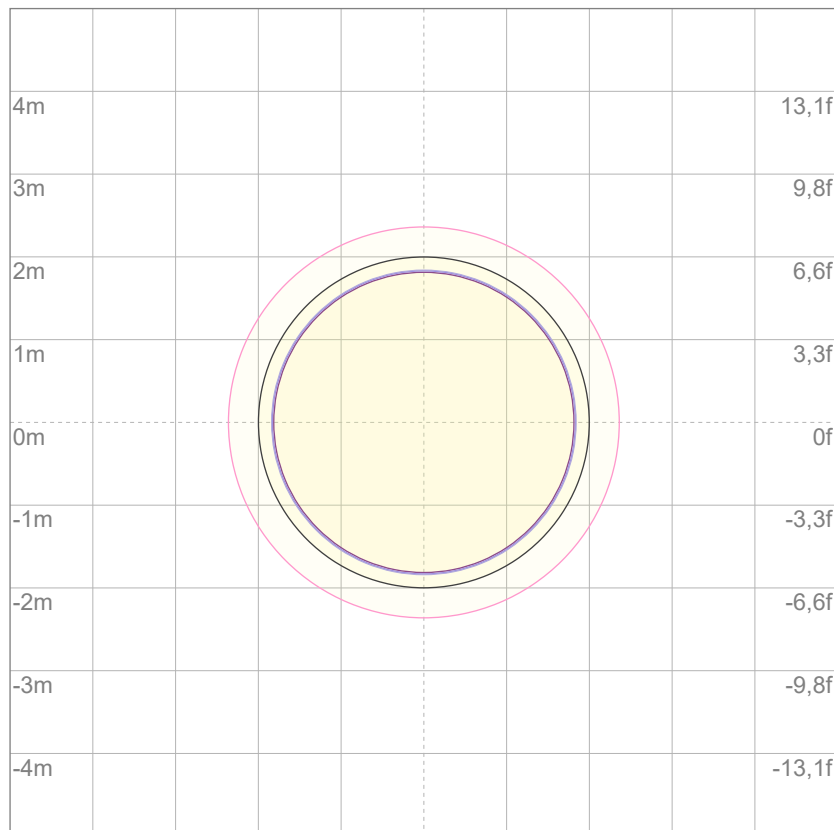

Mounting height: 10 meters (33 feet)

3%	50,0 lx
5%	83,3 lx
10%	167 lx
30%	500 lx
50%	833 lx

Conditions:

Number of c-planes: 2

Lux at center: 1667 lx

*Lux distribution on a surface when lamp is mounted at 10 meters from the surface.*



Total lumen output:

13166 lm

Peak candela output:

163565 cd

Light quality:

CRI: 95,7

Color temperature:

5946 K

PRODUCT NAME:

ECLFWHPVW

MEASURAMENT CONDITIONS:

Beam angle:

PRL19

Target:

6000K

Operator:

Giuseppe della Peruta

Date and time:

07/01/2026 12:11:00

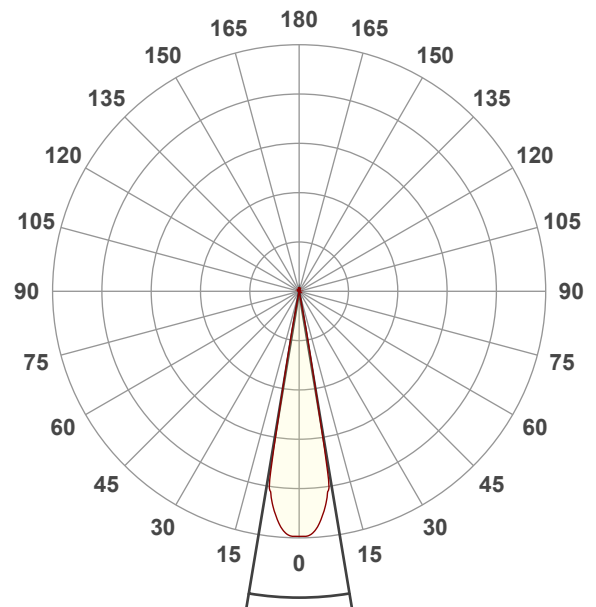

Beam angle 50%: 18,9°

Field angle 10%: 21,2°

Cut off angle 2.5%: 21,8°

Spectra

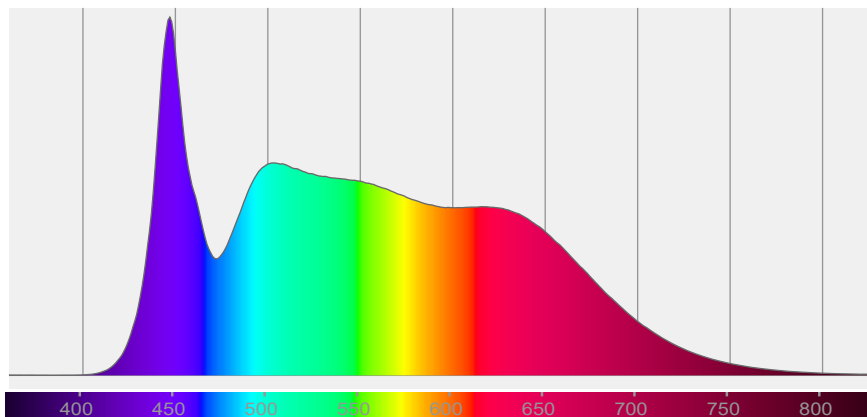

# COLOR DETAILS

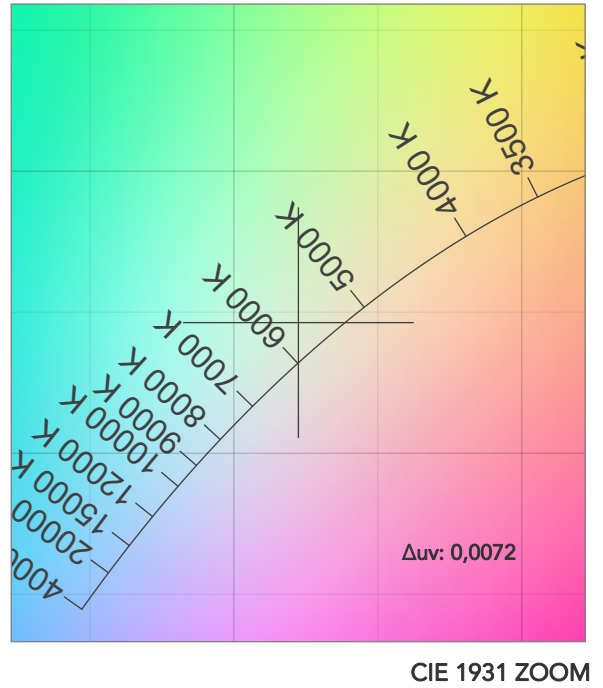
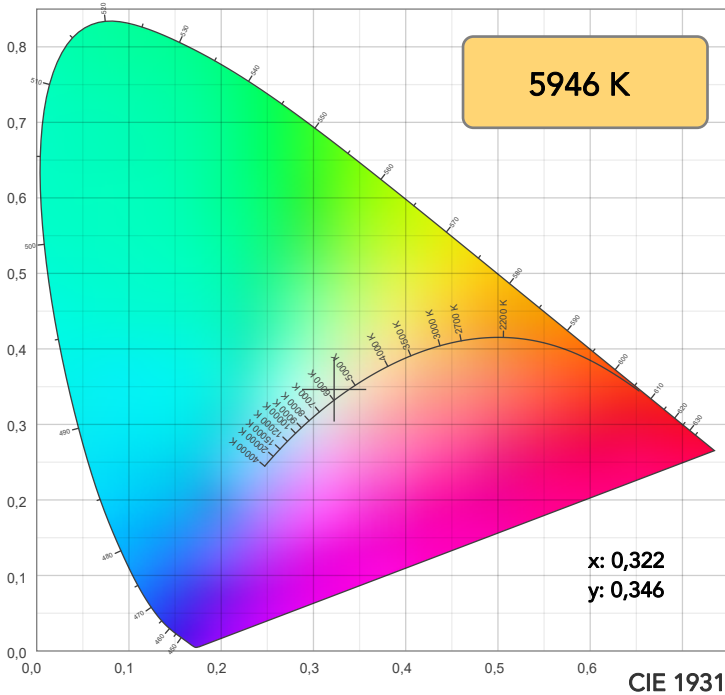

**TM30: 95,0**

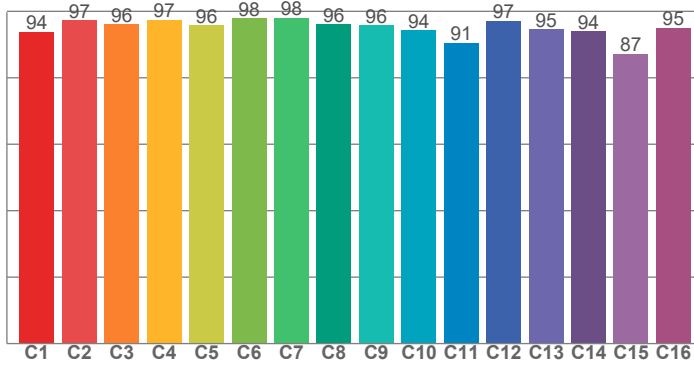

**CRI: 95,7 (R1-R8)**

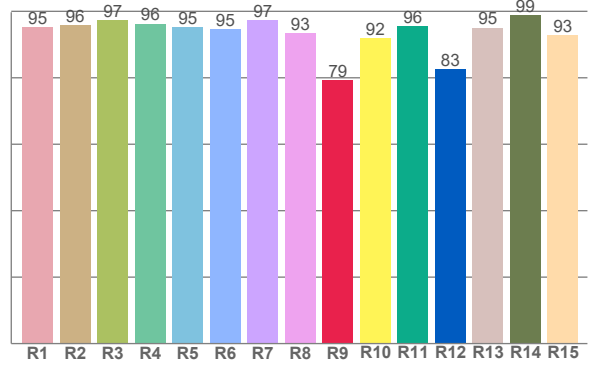

CRI R values, only R1-R8 are used to calculate final CRI value

R1	R2	R3	R4	R5	R6	R7	R8	R9	R10	R11	R12	R13	R14	R15
95,1	95,8	97,4	96,3	95,3	94,6	97,4	93,4	79,3	91,9	95,6	82,5	95,1	99,0	92,9

TM30 C values, 16 binned values out of total of 99 C values

C1	C2	C3	C4	C5	C6	C7	C8	C9	C10	C11	C12	C13	C14	C15	C16
93,9	97,3	96,1	97,5	95,7	97,8	98,1	96,0	95,9	94,2	90,5	97,1	94,6	94,0	87,2	95,0

CQS Q values

Q1	Q2	Q3	Q4	Q5	Q6	Q7	Q8	Q9	Q10	Q11	Q12	Q13	Q14	Q15
95,6	99,6	93,5	95,4	97,4	96,6	97,2	98,6	99,2	98,6	98,4	97,9	97,8	94,6	95,1

**CQS: 96,6**

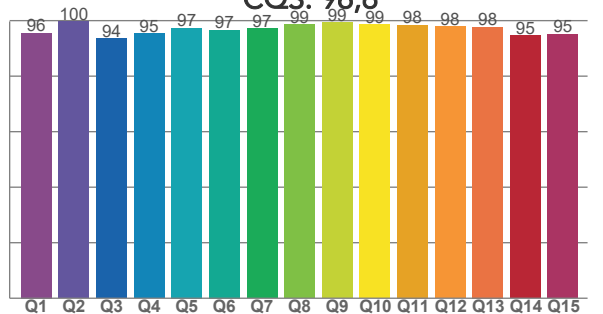

## COLOR PARAMETERS

Color temperature	Color rendering index	Red component	Color fidelity	Color gamut	Color quality scale	Television lighting index	Color coordinate cie 1931	Color coordinate cie 1931	Color deviation from black body
CCT	CRI	CRI R9	TM30 Rf	TM30 Rg	CQS	TLCI	x	y	Δuv
5946 K	95,7	79,3	95,0	99,9	96,6	99	0,322	0,346	0,0072

# TM30 DETAILS

**Rf 95,0**  
Fidelity index Rf

**Rg 99,9**  
Gammut index

Hue Bin	R <sub>f</sub>	Graphic shifts (%)	
		Chroma	Hue
1	94	-2%	-1%
2	97	-1%	0%
3	96	-1%	1%
4	97	-1%	0%
5	96	-2%	0%
6	98	0%	0%
7	98	0%	0%
8	96	-2%	0%
9	96	-2%	3%
10	94	-1%	3%
11	91	2%	6%
12	97	2%	0%
13	95	3%	-2%
14	94	2%	-3%
15	87	6%	-10%
16	95	0%	-3%

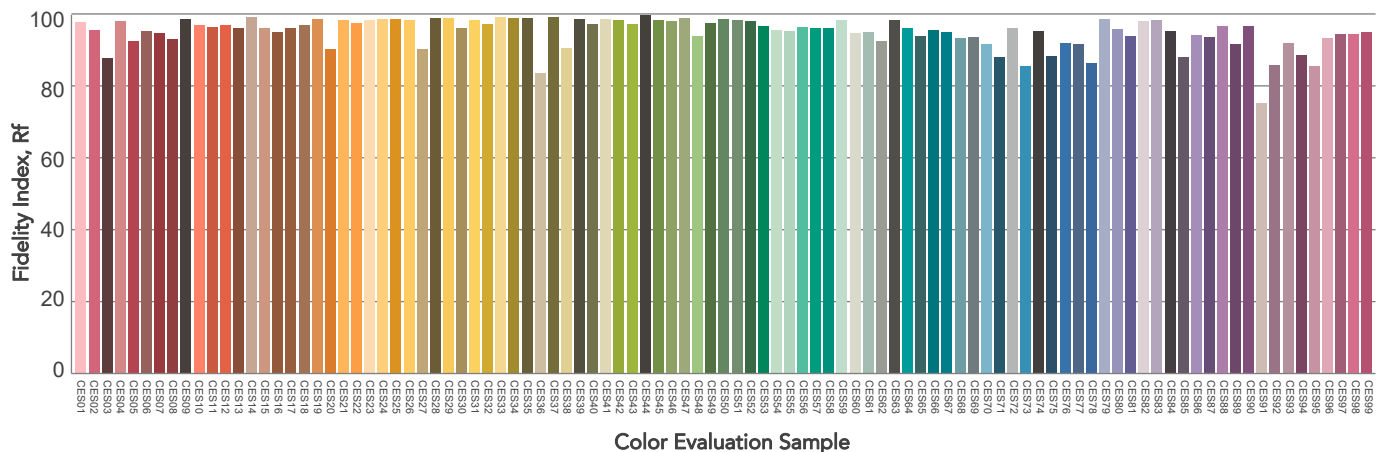
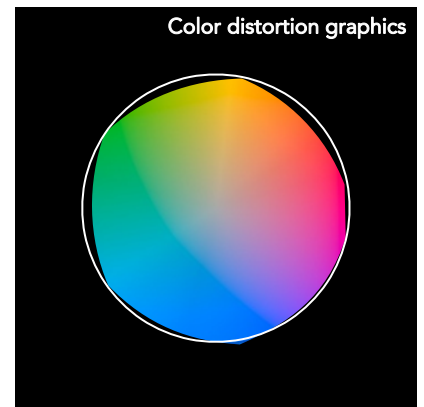
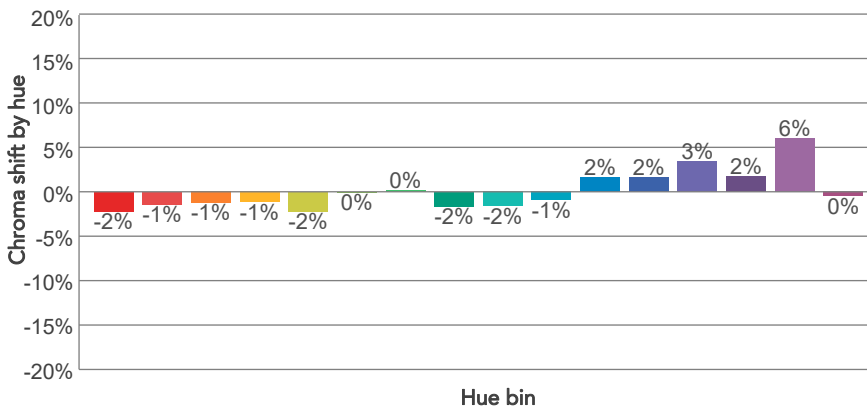
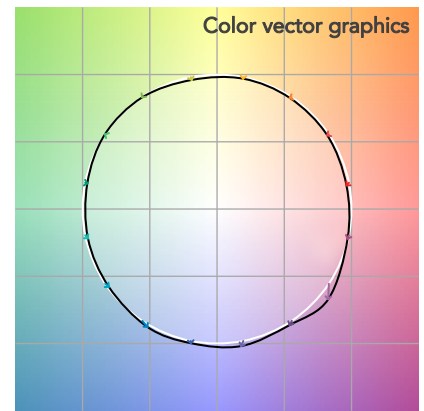
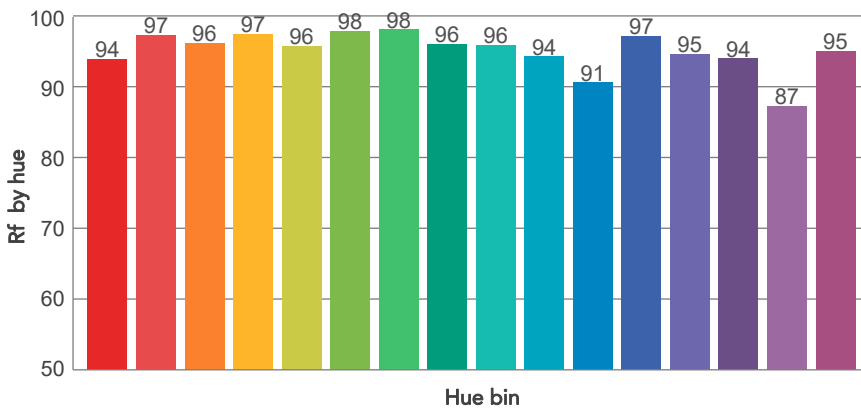
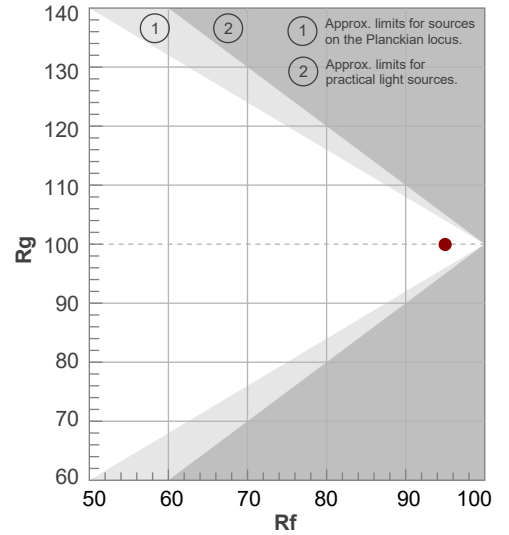

# BEAM DETAILS



Beam angle 50%	Field angle 10%	Cut off angle 2,5%	Intensity ratio in 120° cone	Intensity ratio in 90° cone
18,9°	21,2°	21,8°	100,0%	100,0%

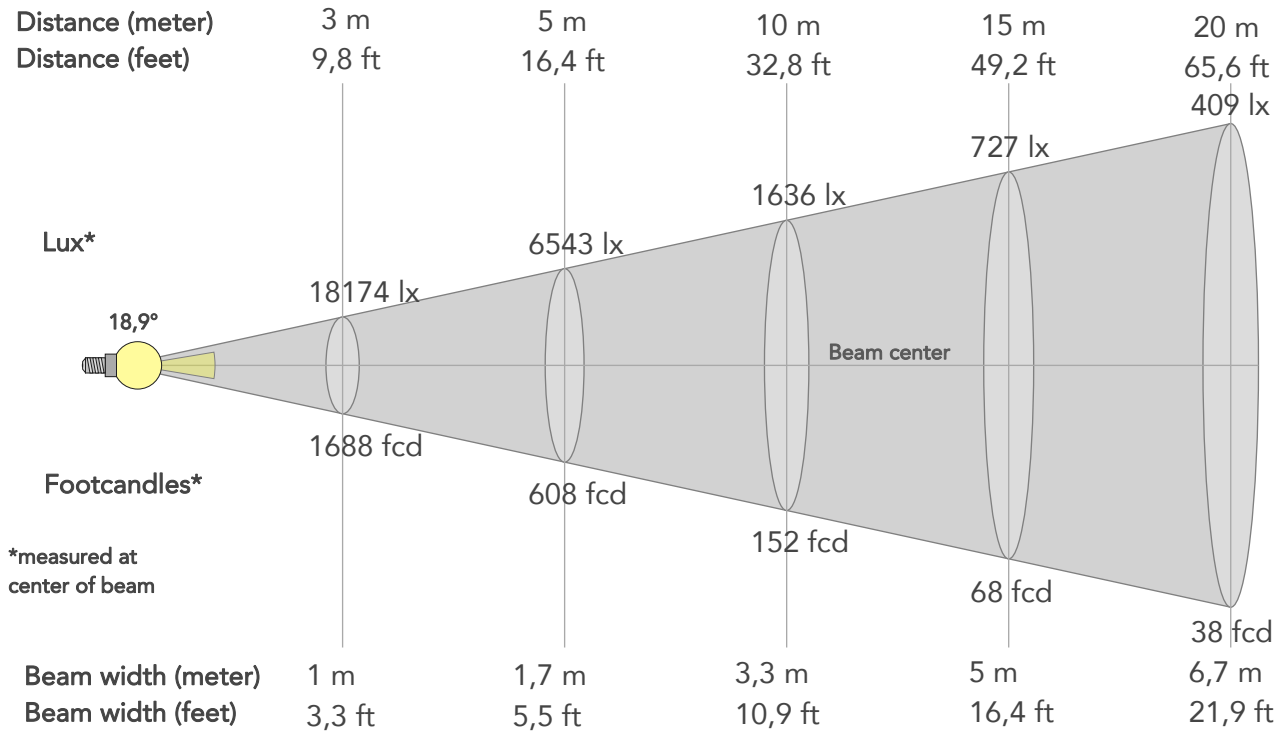

## BEAM INTENSITIES AND WIDTHS

Distance	1m	2m	3m	4m	5m	7,5m	10m	15m	20m	25m	30m	40m	50m
Distance	3,3ft	6,6ft	9,8ft	13,1ft	16,4ft	24,6ft	32,8ft	49,2ft	65,6ft	82ft	98,4ft	131,2ft	164ft
Lux	163565lx	40891lx	18174lx	10223lx	6543lx	2908lx	1636lx	727lx	409lx	262lx	182lx	102lx	65lx
Footcand.	15196fcd	3799fcd	1688fcd	950fcd	608fcd	270fcd	152fcd	68fcd	38fcd	24fcd	17fcd	9fcd	6fcd
Beam wid.	0,3m	0,7m	1m	1,3m	1,7m	2,5m	3,3m	5m	6,7m	8,3m	10m	13,3m	16,7m
Beam wid.	1,1ft	2,2ft	3,3ft	4,4ft	5,5ft	8,2ft	10,9ft	16,4ft	21,9ft	27,3ft	32,8ft	43,7ft	54,7ft

## LINEAR DISTRIBUTION DIAGRAM

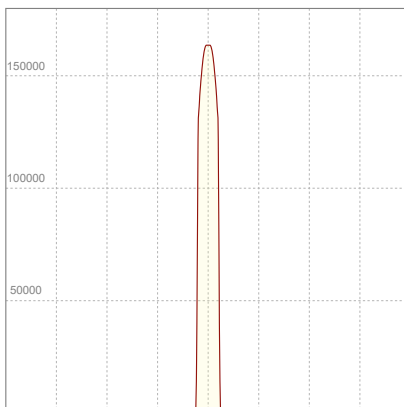

## ELECTRICAL SPECIFICATIONS

Input voltage	Input current	Input power	Power FC	Efficiency
226V	1,94A	426,2W	0,97	31lm/W

# ISO DIAGRAMS

## ISO CANDELA DIAGRAM

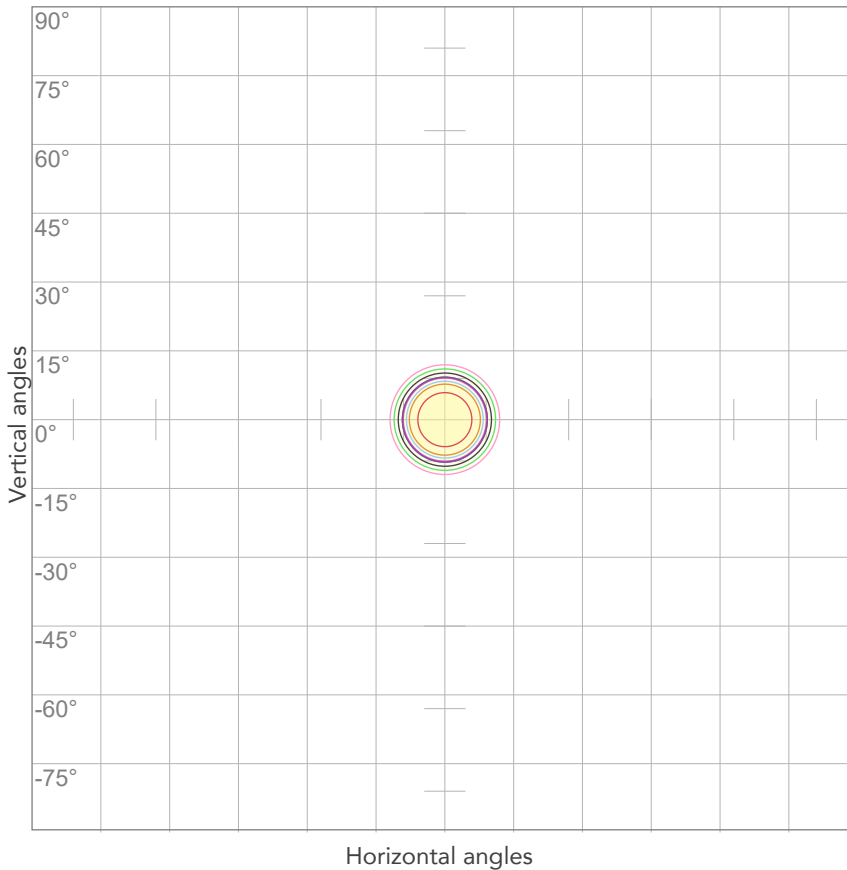

10%	16356 cd
20%	32713 cd
30%	49069 cd
40%	65426 cd
50%	81782 cd
60%	98139 cd
70%	114495 cd
80%	130852 cd

Conditions:

Number of c-planes: 2

Candela at center: 163565 cd

## ISO LUX DIAGRAM

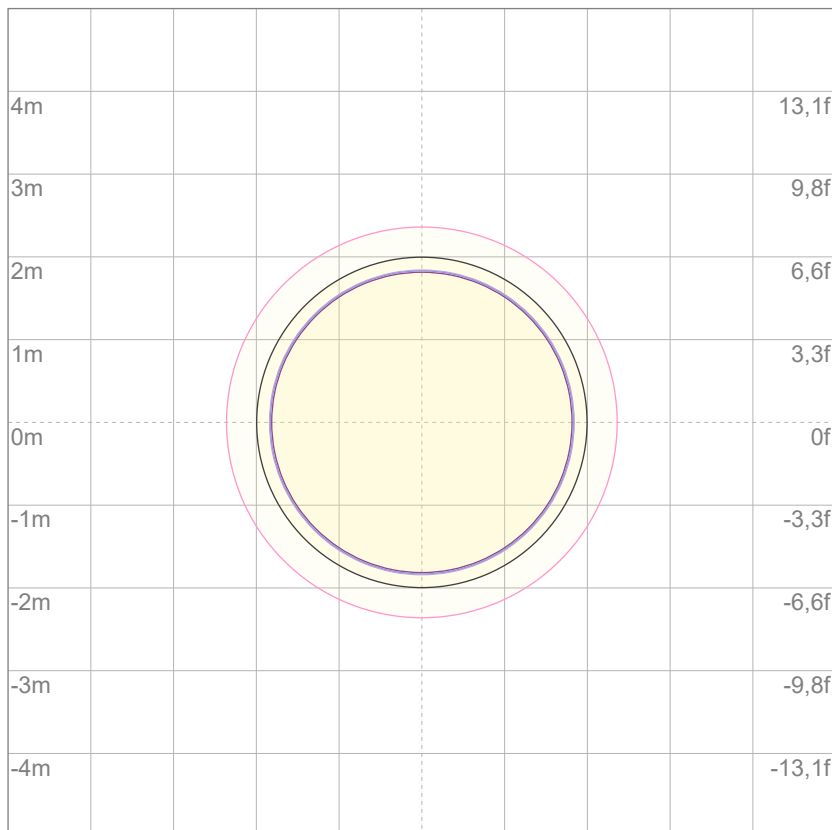

Mounting height: 10 meters (33 feet)

3%	49,1 lx
5%	81,8 lx
10%	164 lx
30%	491 lx
50%	818 lx

Conditions:

Number of c-planes: 2

Lux at center: 1636 lx

*Lux distribution on a surface when lamp is mounted at 10 meters from the surface.*