

Photometric Test Report



EclProfile FWHPVW

450W high quality VariableWhite LED
ellipsoidal, compatible with PRL and PRLZ lenses

(ECLPRL36BK)

CONTENTS

Table of contents	2
Testing process	3
PRL 36° Lens:	
Full On	4
Warm White	9
Cold White	14
2800K	19
3200K	24
4000K	29
5600K	34
6000K	39

TESTING PROCESS

Prolights has its own optical testing laboratory in order to provide accurate photometric reports for its lighting products. The testing laboratory contains certain variety of precise lighting measurement systems that ensure an optimal reading of all the characteristic parameters of the lighting devices. All measurements are made at a controlled room temperature of 20°C without any external light sources. This photometric report is obtained through the data measured by a high precision measurement system and analyzed by a dedicate software.

Prolights measurement instrument

Prolights measurement instrument is a complete measurement system for any light source. It's equipped with two-axis goniometer, that enables to measure the full 3D distribution field of the light source. This instrument measures the light intensity, the beam angle and the most significative colors parameters, like color temperature, spectral distribution, CRI, CQS, TM-30 with a very high accuracy rate.

Please Note: All measurements are made with light source at operating temperature. Before starting the measurement, the instrument analyzes the process of the light source during the heating phase. The measuring process of all the parameters begins only when the light emission is stable, that is with a variation of less than 0.5% in a 15 minutes time frame.

Prolights measurement software

The software provides user friendly interface for the operator who does the measurements, and it also analyzes and processes all the collected data by the instrument. With this software it is possible to see the measured data in real-time and it is possible to examine all the measured data and graphics afterwards as well. All information is collected in a specific Prolights template, and the software creates also IES and LDT files, which are widely used to transfer the photometric data, and to develop lighting system.

Additionally, the fixtures are rechecked using various hand-held instruments like Sekonic C-700 and Gossen Mavospec Base, this is done to ensure, that the data in the photometric report are as accurate as possible.



Total lumen output:

16379 lm

Peak candela output:

58687 cd

Light quality:

CRI: 97,6

Color temperature:

4155 K

PRODUCT NAME:

ECLFWHPVW

MEASURAMENT CONDITIONS:

Beam angle:

PRL36

Target:

Full On

Operator:

Giuseppe della Peruta

Date and time:

08/01/2026 16:00:31

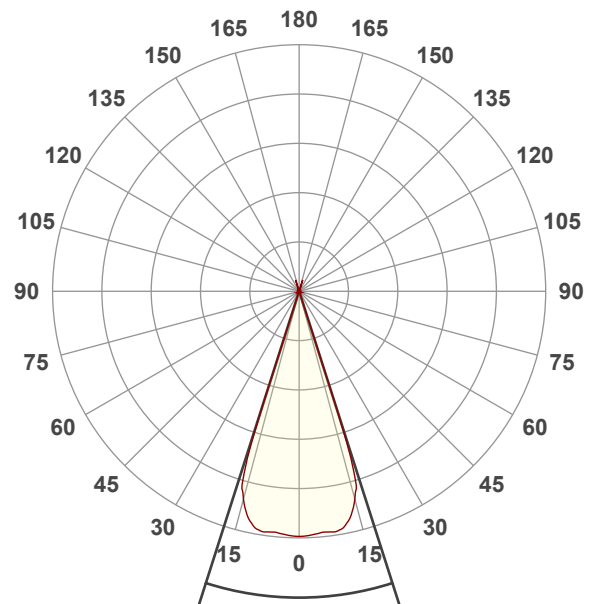

Beam angle 50%: 35,5°

Field angle 10%: 36,8°

Cut off angle 2.5%: 37°

Spectra

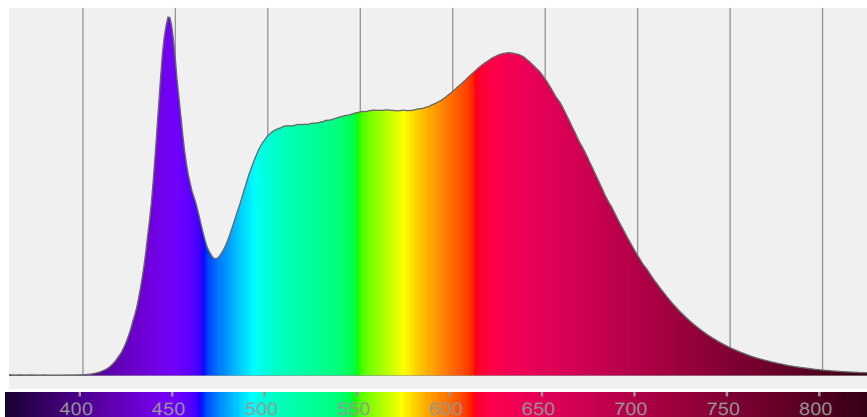

COLOR DETAILS

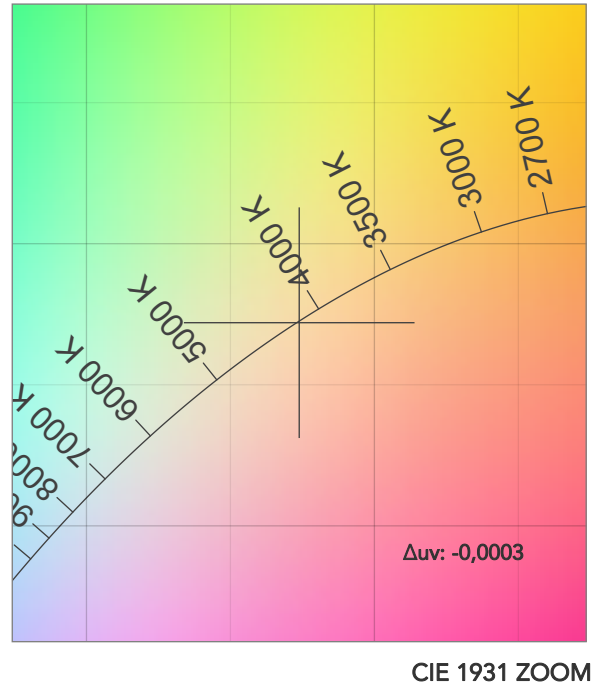
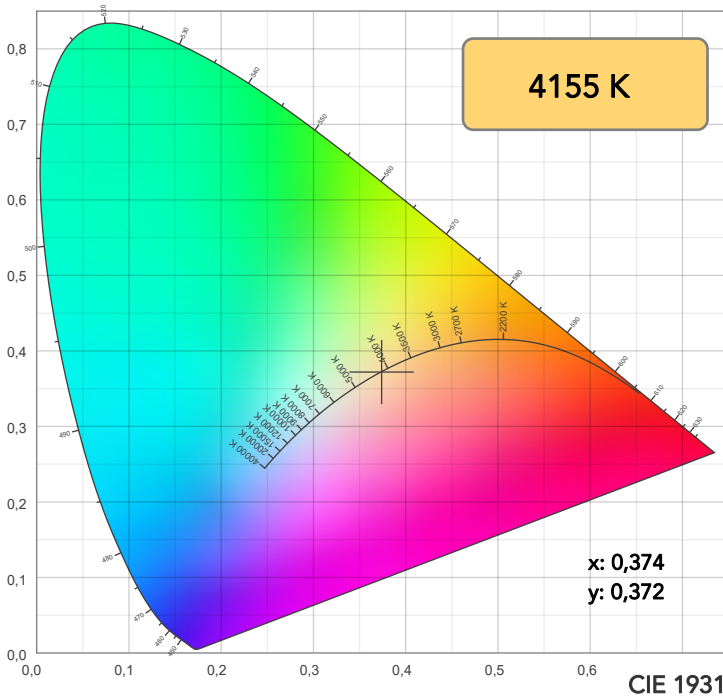

TM30: 96,1

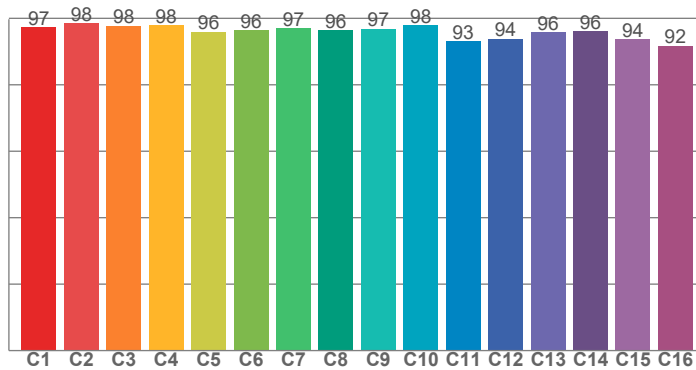

CRI: 97,6 (R1-R8)

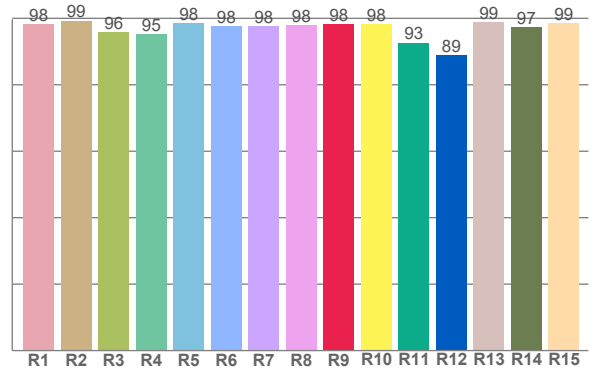

CRI R values, only R1-R8 are used to calculate final CRI value

R1	R2	R3	R4	R5	R6	R7	R8	R9	R10	R11	R12	R13	R14	R15
98,3	99,3	95,9	95,2	98,5	97,7	97,6	98,0	98,2	98,2	92,6	88,9	98,9	97,4	98,5

TM30 C values, 16 binned values out of total of 99 C values

C1	C2	C3	C4	C5	C6	C7	C8	C9	C10	C11	C12	C13	C14	C15	C16
97,4	98,5	97,7	97,9	95,9	96,5	97,0	96,5	96,9	97,9	93,1	93,9	95,8	96,2	93,7	91,8

CQS Q values

Q1	Q2	Q3	Q4	Q5	Q6	Q7	Q8	Q9	Q10	Q11	Q12	Q13	Q14	Q15
99,5	99,5	94,2	97,8	97,4	95,4	98,1	99,1	98,7	99,0	99,4	98,6	98,6	99,4	99,6

CQS: 97,7

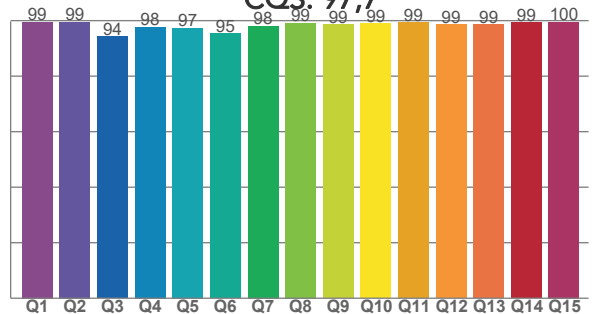

COLOR PARAMETERS

Color temperature	Color rendering index	Red component	Color fidelity	Color gamut	Color quality scale	Television lighting index	Color coordinate cie 1931	Color coordinate cie 1931	Color deviation from black body
CCT	CRI	CRI R9	TM30 Rf	TM30 Rg	CQS	TLCI	x	y	Δuv
4155 K	97,6	98,2	96,1	102,6	97,7	98	0,374	0,372	-0,0003

TM30 DETAILS

Rf 96,1
Fidelity index Rf

Rg 102,6
Gammut index

Hue Bin	R _f	Graphic shifts (%)	
		Chroma	Hue
1	97	0%	-1%
2	98	0%	-1%
3	98	0%	1%
4	98	0%	0%
5	96	0%	1%
6	96	2%	1%
7	97	2%	0%
8	96	1%	0%
9	97	1%	1%
10	98	0%	0%
11	93	2%	4%
12	94	3%	2%
13	96	4%	-1%
14	96	2%	1%
15	94	3%	-3%
16	92	3%	-5%

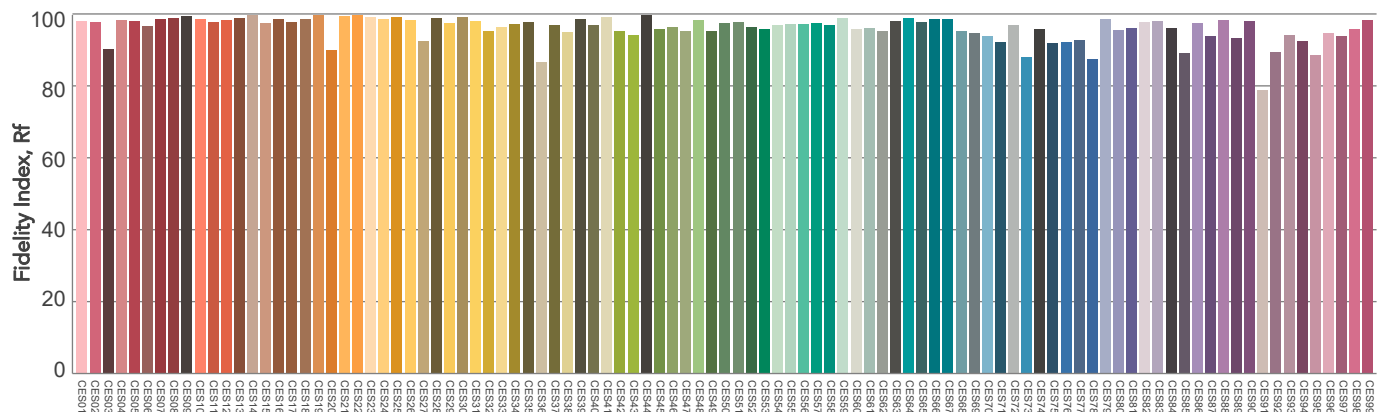
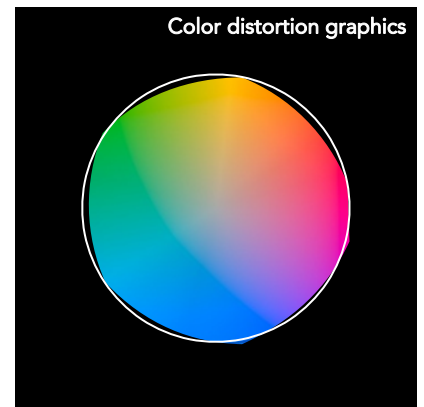
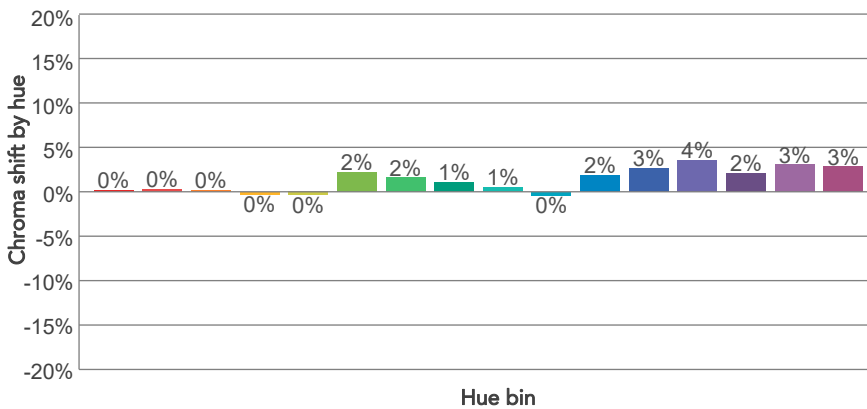
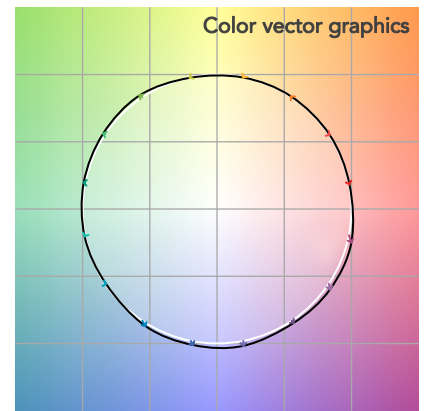
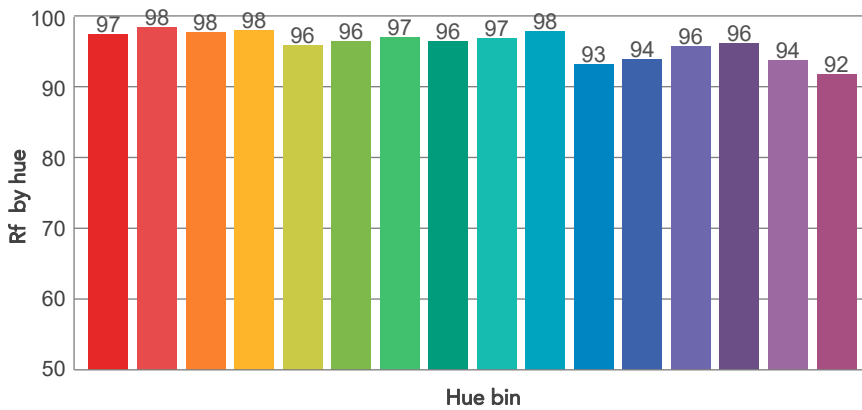
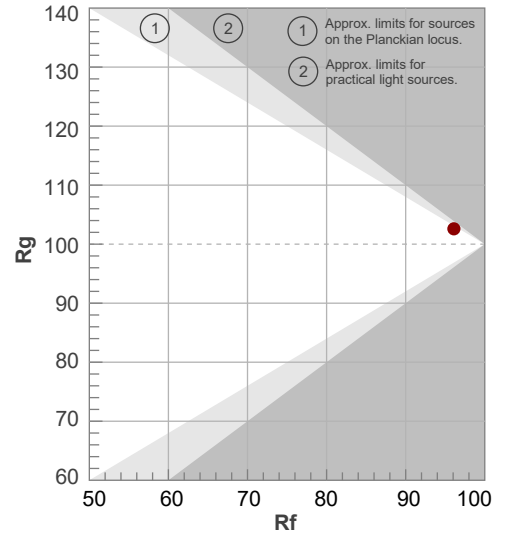

Color Evaluation Sample

BEAM DETAILS



Beam angle 50%	Field angle 10%	Cut off angle 2,5%	Intensity ratio in 120° cone	Intensity ratio in 90° cone
35,5°	36,8°	37°	99,8%	99,8%

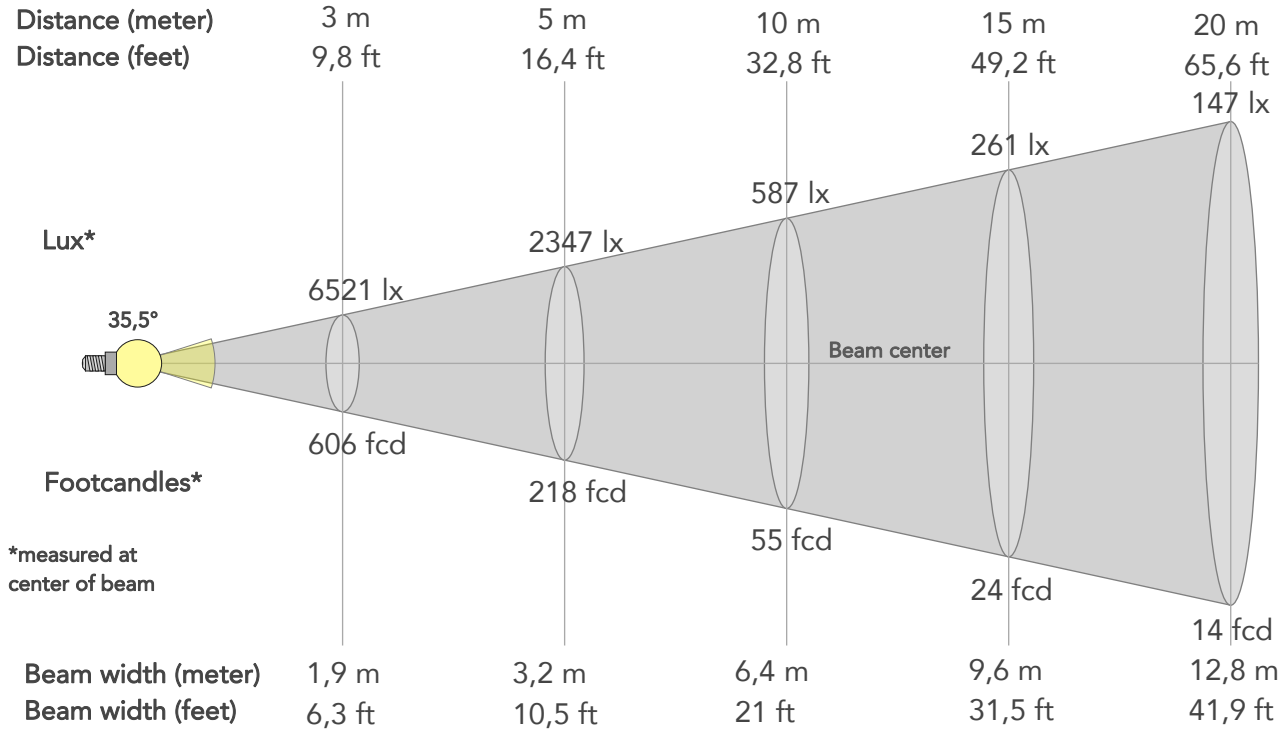

*measured at center of beam

BEAM INTENSITIES AND WIDTHS

Distance	1m	2m	3m	4m	5m	7,5m	10m	15m	20m	25m	30m	40m	50m
Distance	3,3ft	6,6ft	9,8ft	13,1ft	16,4ft	24,6ft	32,8ft	49,2ft	65,6ft	82ft	98,4ft	131,2ft	164ft
Lux	58687lx	14672lx	6521lx	3668lx	2347lx	1043lx	587lx	261lx	147lx	94lx	65lx	37lx	23lx
Footcand.	5452fcd	1363fcd	606fcd	341fcd	218fcd	97fcd	55fcd	24fcd	14fcd	9fcd	6fcd	3fcd	2fcd
Beam wid.	0,6m	1,3m	1,9m	2,6m	3,2m	4,8m	6,4m	9,6m	12,8m	16m	19,2m	25,6m	32m
Beam wid.	2,1ft	4,2ft	6,3ft	8,4ft	10,5ft	15,7ft	21ft	31,5ft	41,9ft	52,4ft	62,9ft	83,9ft	104,9ft

LINEAR DISTRIBUTION DIAGRAM

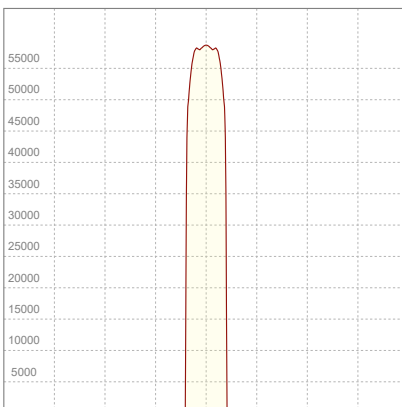

ELECTRICAL SPECIFICATIONS

Input voltage	Input current	Input power	Power FC	Efficiency
226V	2,02A	442,4W	0,97	37lm/W

ISO DIAGRAMS

ISO CANDELA DIAGRAM

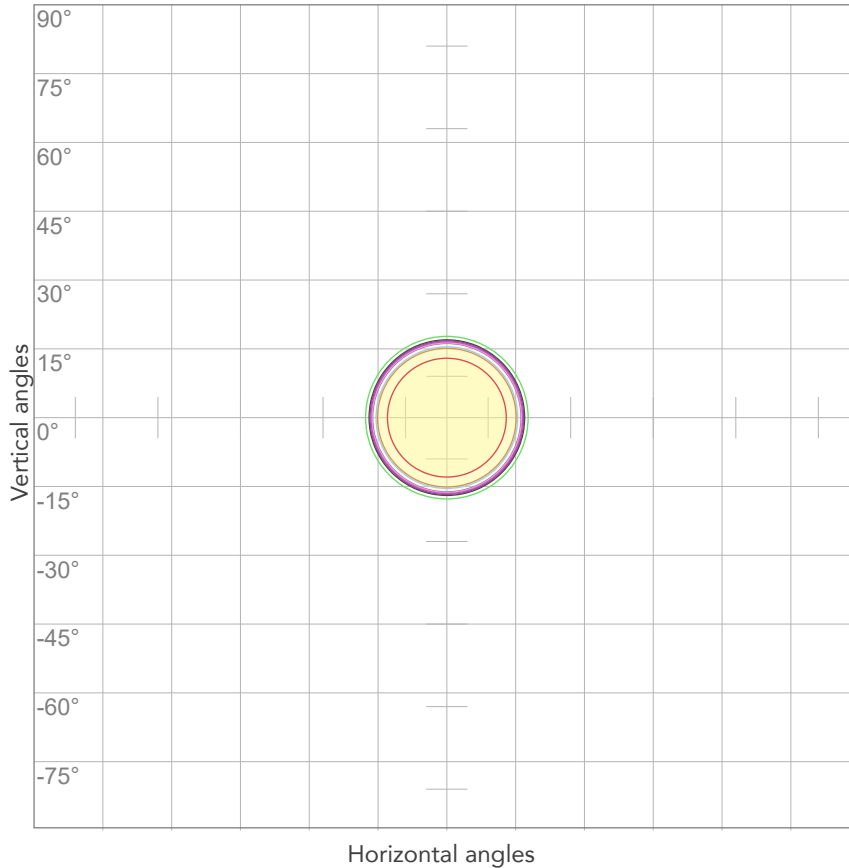

10%	5869 cd
20%	11737 cd
30%	17606 cd
40%	23475 cd
50%	29344 cd
60%	35212 cd
70%	41081 cd
80%	46950 cd

Conditions:

Number of c-planes: 2

Candela at center: 58687 cd

ISO LUX DIAGRAM

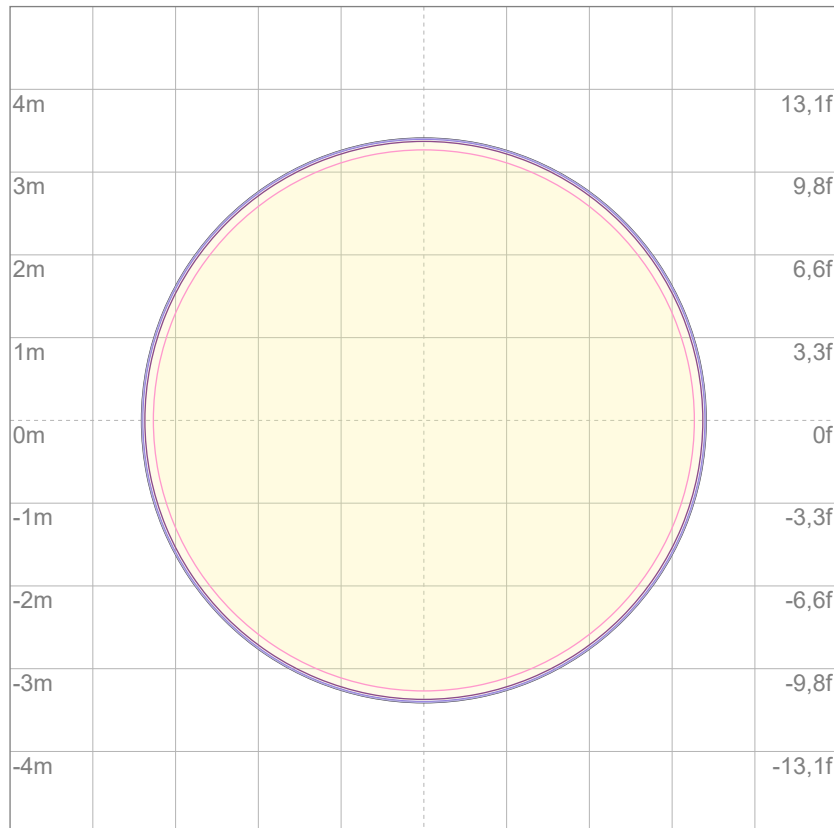

3%	17,6 lx
5%	29,3 lx
10%	58,7 lx
30%	176 lx
50%	293 lx

Conditions:

Number of c-planes: 2

Lux at center: 587 lx

Lux distribution on a surface when lamp is mounted at 10 meters from the surface.

Mounting height: 10 meters (33 feet)



Total lumen output:

12243 lm

Peak candela output:

43684 cd

Light quality:

CRI: 96,9

Color temperature:

2601 K

PRODUCT NAME:

ECLFWHPVW

MEASURAMENT CONDITIONS:

Beam angle:

PRL36

Target:

Warm White

Operator:

Giuseppe della Peruta

Date and time:

08/01/2026 16:04:07

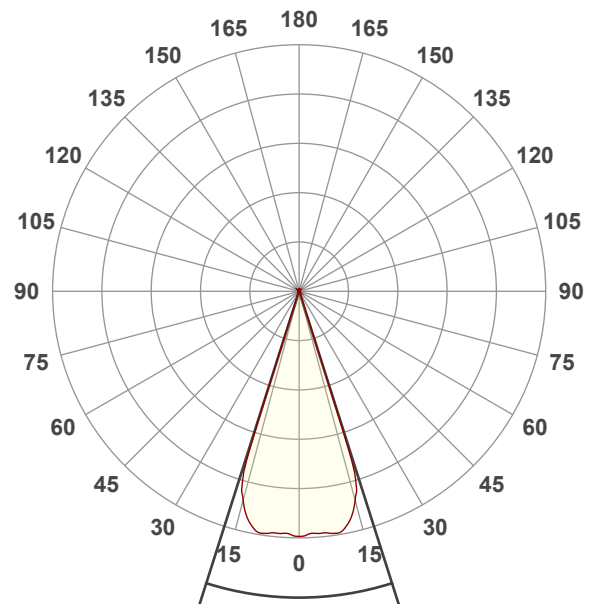

Beam angle 50%: 35,3°

Field angle 10%: 36,6°

Cut off angle 2.5%: 38,1°

Spectra

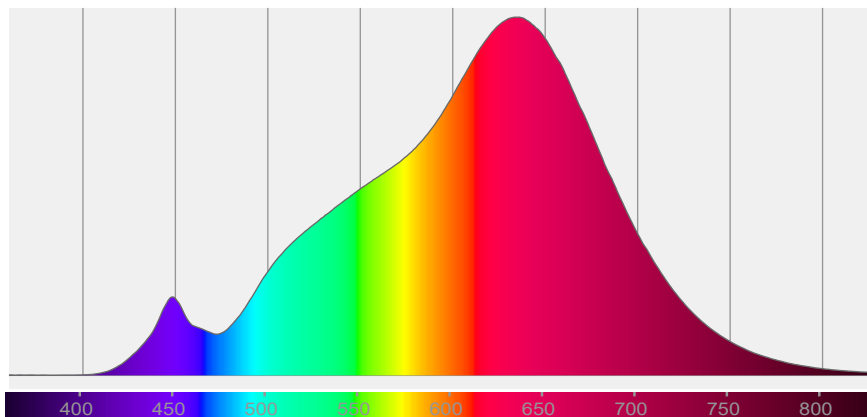

COLOR DETAILS

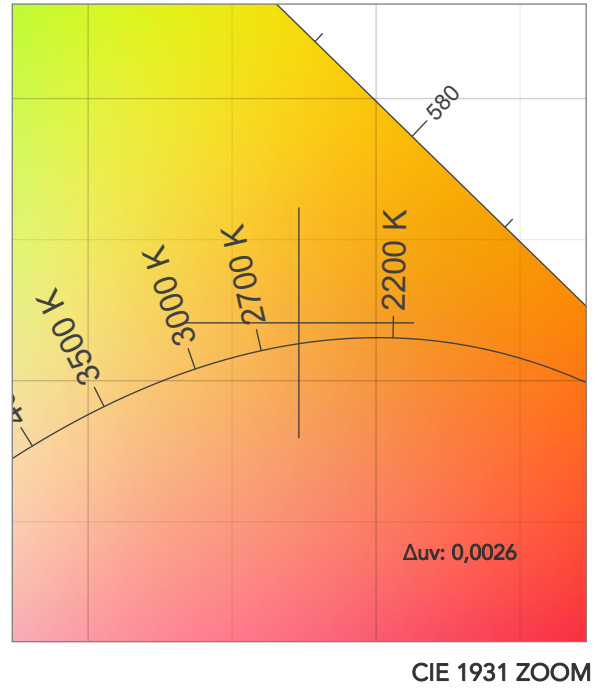
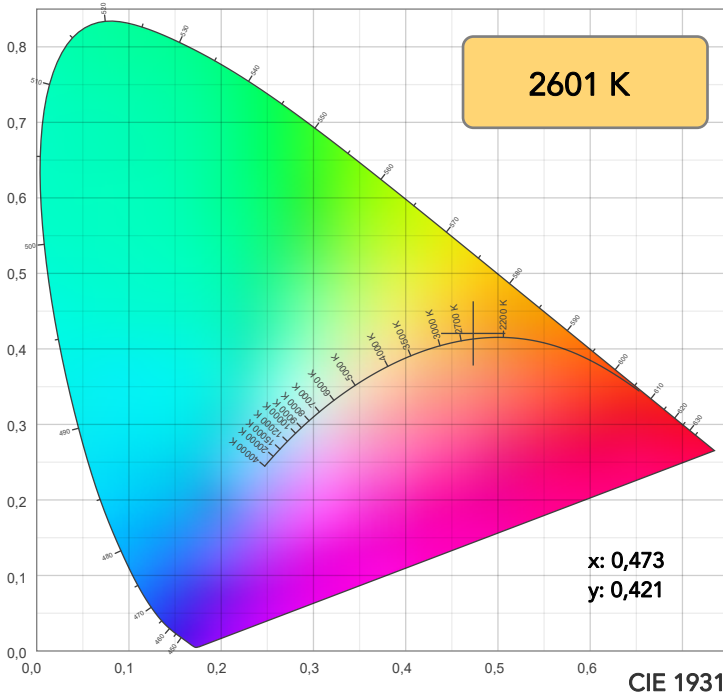

TM30: 96,1

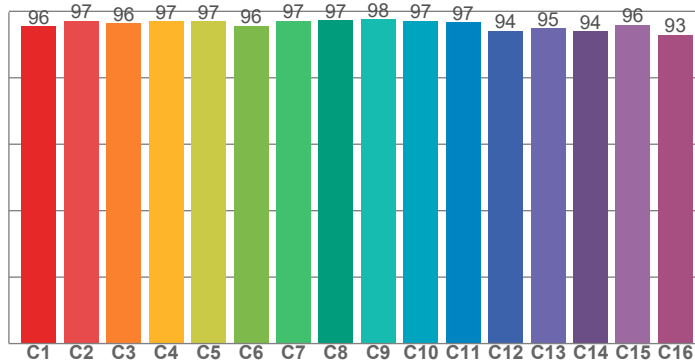

CRI: 96,9 (R1-R8)

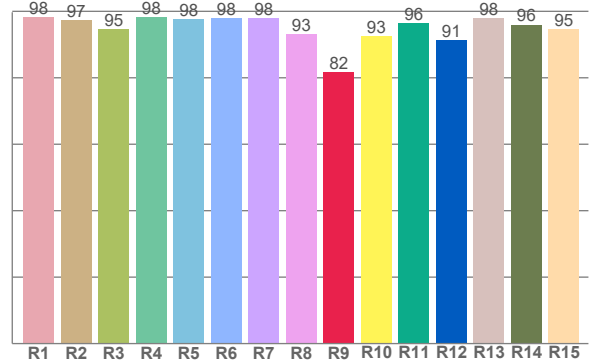

CQS: 92,3

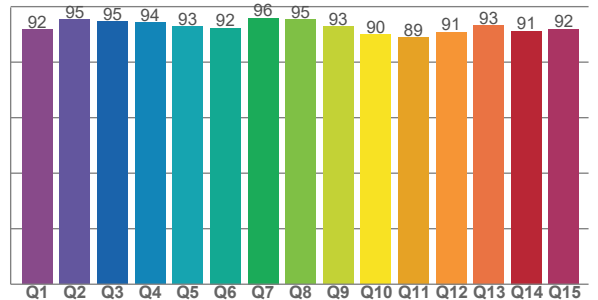

CRI R values, only R1-R8 are used to calculate final CRI value

R1	R2	R3	R4	R5	R6	R7	R8	R9	R10	R11	R12	R13	R14	R15
98,2	97,3	94,7	98,3	97,7	98,0	98,0	93,1	81,7	92,6	96,4	91,4	97,9	96,0	94,7

TM30 C values, 16 binned values out of total of 99 C values

C1	C2	C3	C4	C5	C6	C7	C8	C9	C10	C11	C12	C13	C14	C15	C16
95,6	97,2	96,5	96,9	97,0	95,7	97,1	97,4	97,5	97,2	96,7	94,2	94,9	94,0	96,0	92,9

CQS Q values

Q1	Q2	Q3	Q4	Q5	Q6	Q7	Q8	Q9	Q10	Q11	Q12	Q13	Q14	Q15
91,8	95,3	94,6	94,3	92,8	92,3	96,0	95,5	92,9	89,9	89,0	90,8	93,1	91,3	91,9

COLOR PARAMETERS

Color temperature	Color rendering index	Red component	Color fidelity	Color gamut	Color quality scale	Television lighting index	Color coordinate cie 1931	Color coordinate cie 1931	Color deviation from black body
CCT	CRI	CRI R9	TM30 Rf	TM30 Rg	CQS	TLCI	x	y	Δuv
2601 K	96,9	81,7	96,1	100,1	92,3	96	0,473	0,421	0,0026

TM30 DETAILS

Rf 96,1
Fidelity index Rf

Rg 100,1
Gammut index

Hue Bin	R _f	Graphic shifts (%)	
		Chroma	Hue
1	96	-2%	-1%
2	97	-1%	0%
3	96	-1%	1%
4	97	-1%	1%
5	97	0%	3%
6	96	2%	2%
7	97	1%	-1%
8	97	1%	0%
9	98	0%	-1%
10	97	-1%	0%
11	97	0%	2%
12	94	2%	-1%
13	95	2%	-4%
14	94	2%	-4%
15	96	0%	-2%
16	93	-1%	-5%

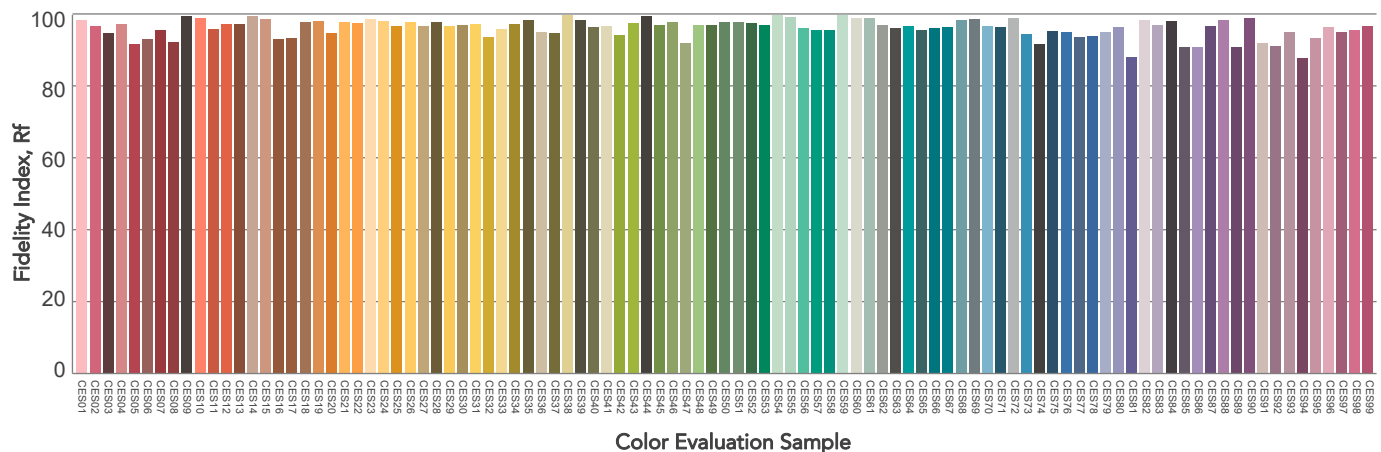
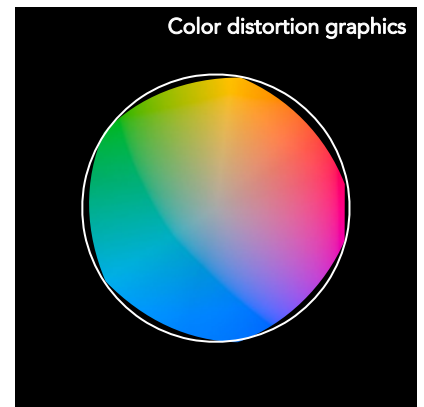
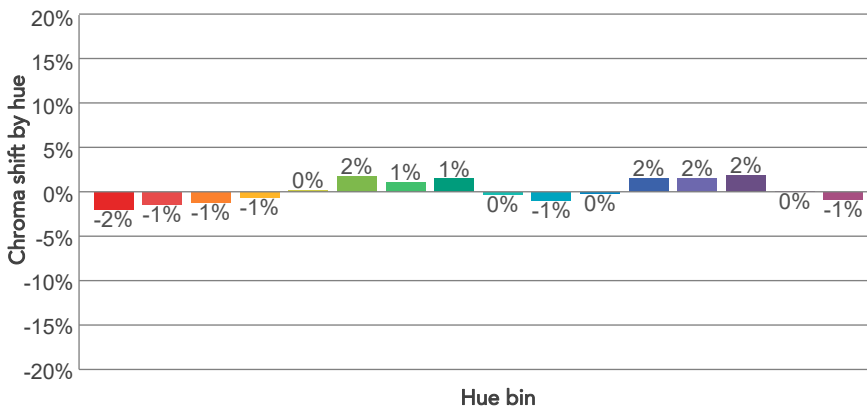
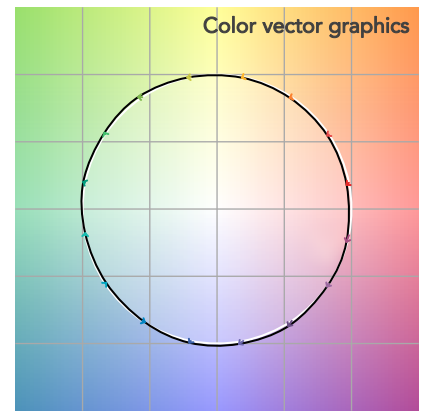
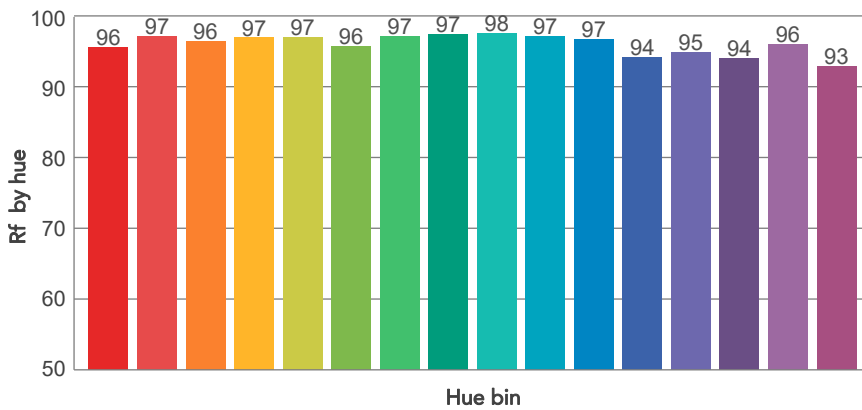
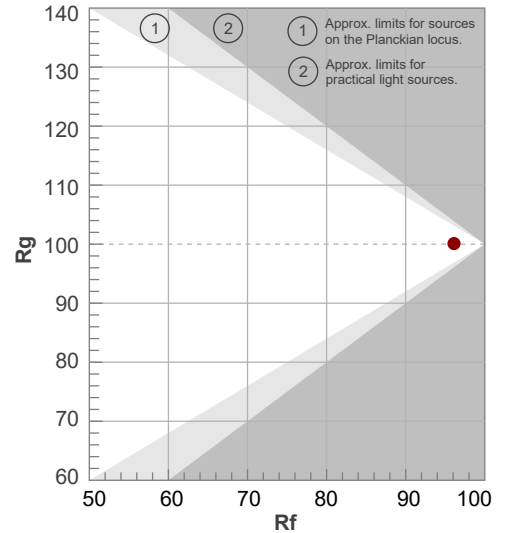

BEAM DETAILS



Beam angle 50%	Field angle 10%	Cut off angle 2,5%	Intensity ratio in 120° cone	Intensity ratio in 90° cone
35,3°	36,6°	38,1°	99,8%	99,8%

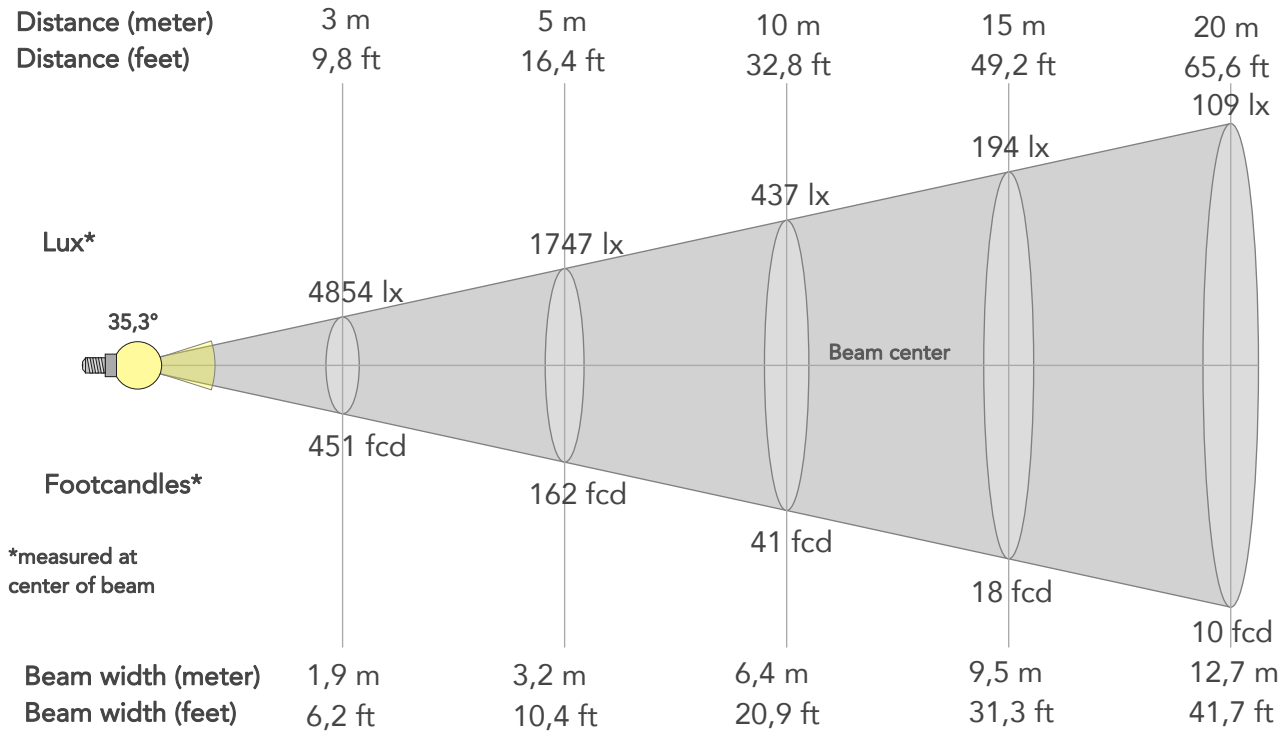

BEAM INTENSITIES AND WIDTHS

Distance	1m	2m	3m	4m	5m	7,5m	10m	15m	20m	25m	30m	40m	50m
Distance	3,3ft	6,6ft	9,8ft	13,1ft	16,4ft	24,6ft	32,8ft	49,2ft	65,6ft	82ft	98,4ft	131,2ft	164ft
Lux	43684lx	10921lx	4854lx	2730lx	1747lx	777lx	437lx	194lx	109lx	70lx	49lx	27lx	17lx
Footcand.	4058fcd	1015fcd	451fcd	254fcd	162fcd	72fcd	41fcd	18fcd	10fcd	6fcd	5fcd	3fcd	2fcd
Beam wid.	0,6m	1,3m	1,9m	2,5m	3,2m	4,8m	6,4m	9,5m	12,7m	15,9m	19,1m	25,5m	31,8m
Beam wid.	2,1ft	4,2ft	6,2ft	8,3ft	10,4ft	15,7ft	20,9ft	31,3ft	41,7ft	52,2ft	62,6ft	83,5ft	104,4ft

LINEAR DISTRIBUTION DIAGRAM

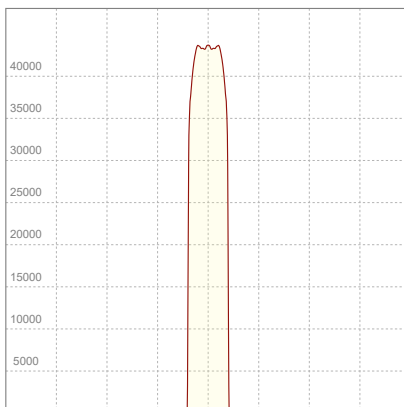

ELECTRICAL SPECIFICATIONS

Input voltage	Input current	Input power	Power FC	Efficiency
226V	1,75A	382,6W	0,97	32lm/W

ISO DIAGRAMS

ISO CANDELA DIAGRAM

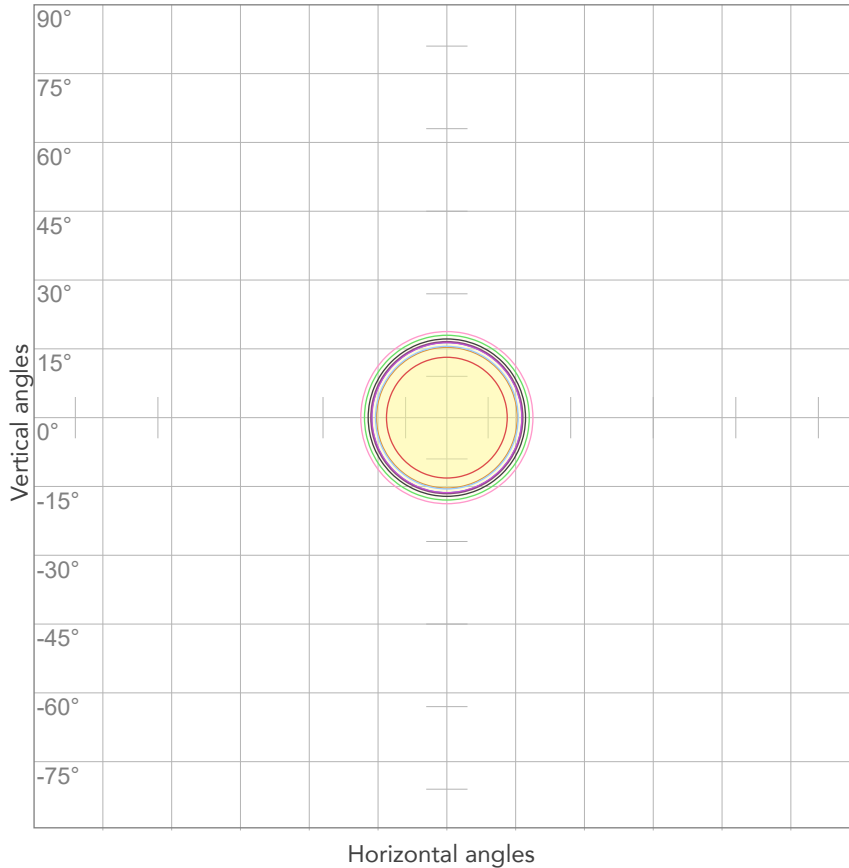

10%	4368 cd
20%	8737 cd
30%	13105 cd
40%	17474 cd
50%	21842 cd
60%	26210 cd
70%	30579 cd
80%	34947 cd

Conditions:

Number of c-planes: 2

Candela at center: 43684 cd

ISO LUX DIAGRAM

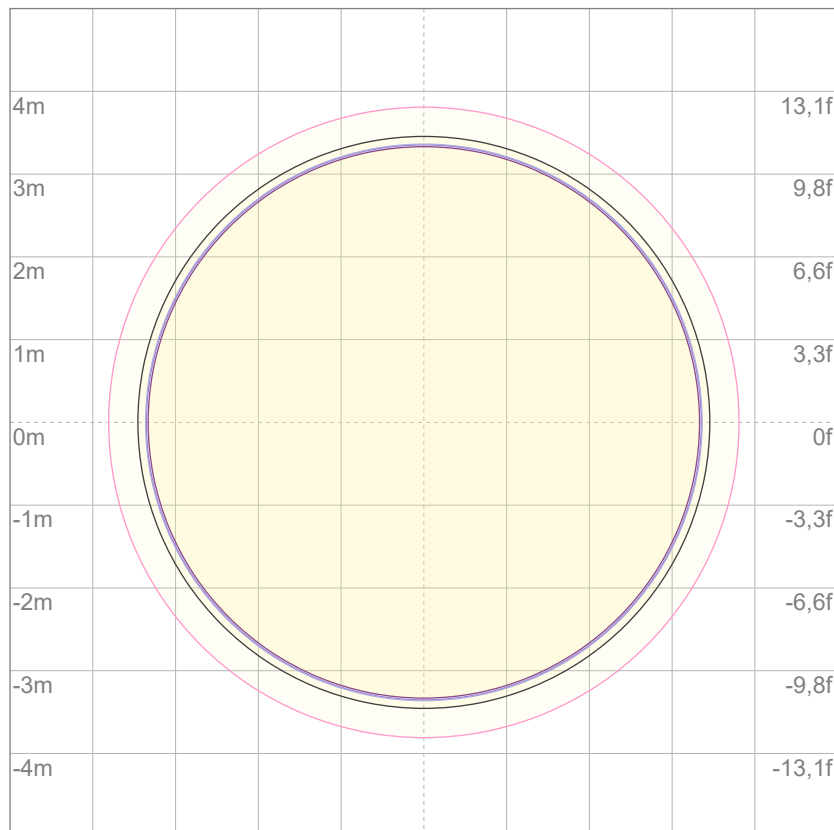

Mounting height: 10 meters (33 feet)

3%	13,1 lx
5%	21,8 lx
10%	43,7 lx
30%	131 lx
50%	218 lx

Conditions:

Number of c-planes: 2

Lux at center: 437 lx

Lux distribution on a surface when lamp is mounted at 10 meters from the surface.



Total lumen output:

15545 lm

Peak candela output:

56483 cd

Light quality:

CRI: 94,7

Color temperature:

6547 K

PRODUCT NAME:

ECLFWHPVW

MEASURAMENT CONDITIONS:

Beam angle:

PRL36

Target:

Cold White

Operator:

Giuseppe della Peruta

Date and time:

08/01/2026 16:08:05

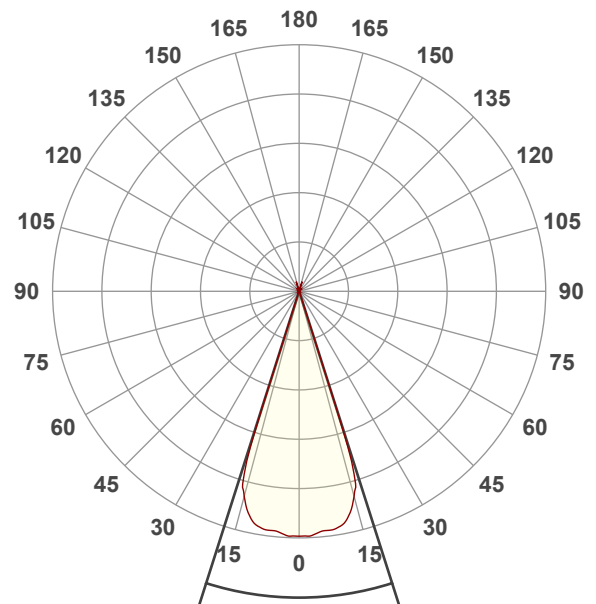

Beam angle 50%: 35,3°

Field angle 10%: 36,7°

Cut off angle 2.5%: 36,9°

Spectra

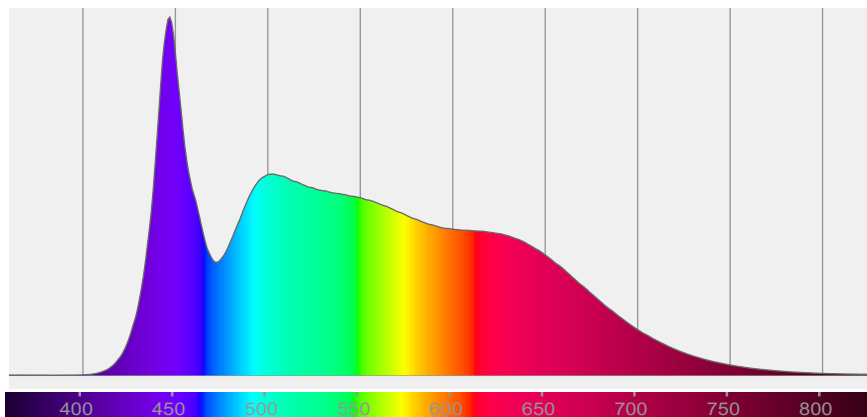

COLOR DETAILS

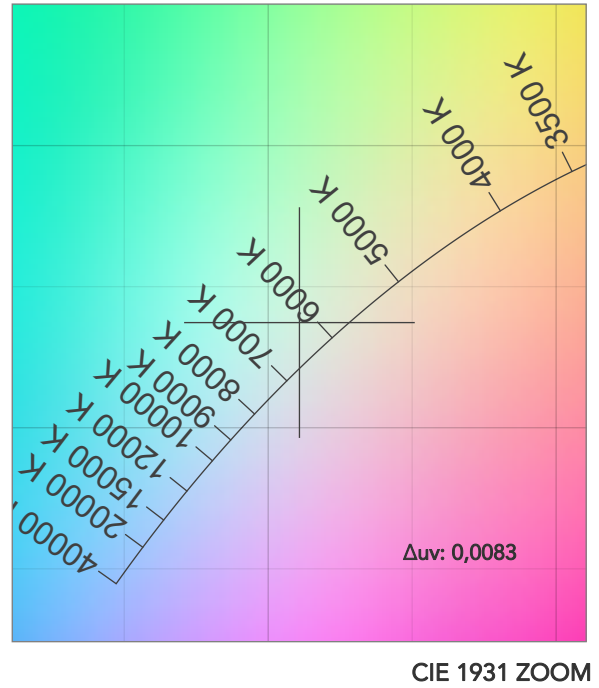
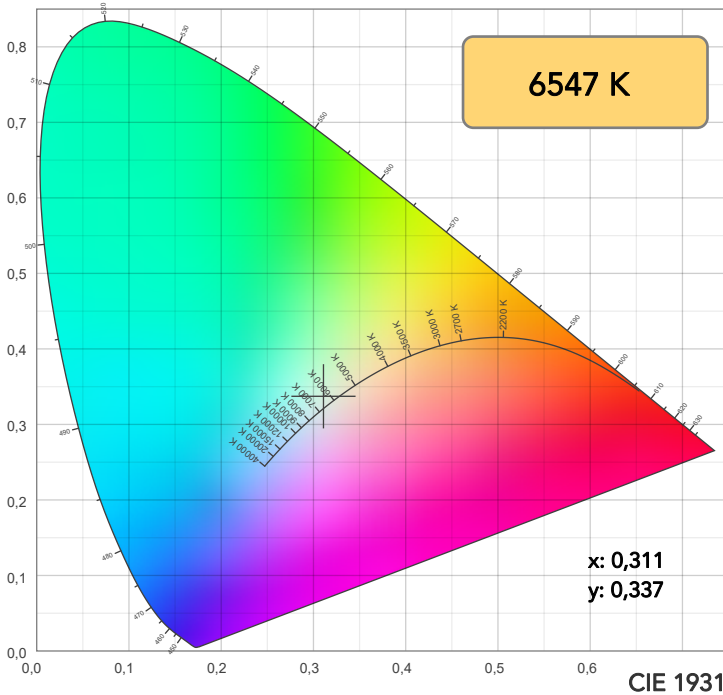

TM30: 94,3

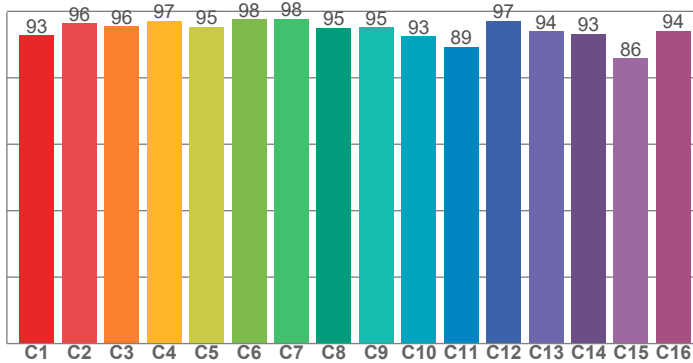

CRI: 94,7 (R1-R8)

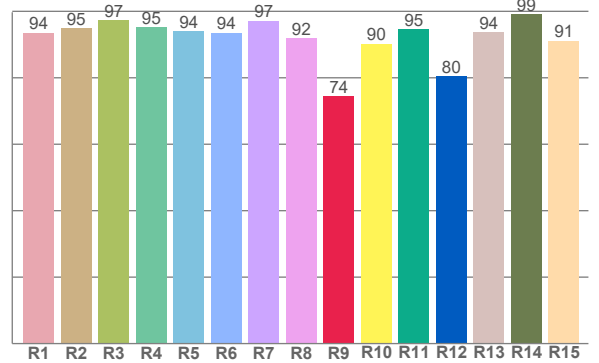

CRI R values, only R1-R8 are used to calculate final CRI value

R1	R2	R3	R4	R5	R6	R7	R8	R9	R10	R11	R12	R13	R14	R15
93,6	94,9	97,4	95,2	94,0	93,6	97,2	92,0	74,4	90,2	94,6	80,5	93,6	99,1	91,2

TM30 C values, 16 binned values out of total of 99 C values

C1	C2	C3	C4	C5	C6	C7	C8	C9	C10	C11	C12	C13	C14	C15	C16
92,7	96,5	95,5	97,1	95,3	97,6	97,8	95,0	95,1	92,5	89,4	97,1	94,0	93,2	85,9	94,1

CQS Q values

Q1	Q2	Q3	Q4	Q5	Q6	Q7	Q8	Q9	Q10	Q11	Q12	Q13	Q14	Q15
94,9	99,6	93,2	94,6	96,8	96,2	96,6	98,0	98,8	98,4	98,1	97,3	97,0	93,4	94,1

CQS: 96,0

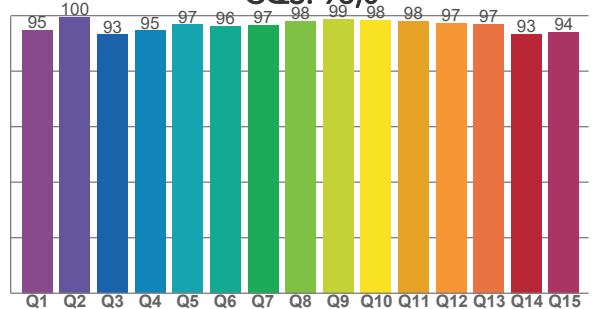

COLOR PARAMETERS

Color temperature	Color rendering index	Red component	Color fidelity	Color gamut	Color quality scale	Television lighting index	Color coordinate cie 1931	Color coordinate cie 1931	Color deviation from black body
CCT	CRI	CRI R9	TM30 Rf	TM30 Rg	CQS	TLCI	x	y	Δuv
6547 K	94,7	74,4	94,3	99,0	96,0	99	0,311	0,337	0,0083

TM30 DETAILS

Rf 94,3
Fidelity index Rf

Rg 99,0
Gammut index

Hue Bin	R _f	Graphic shifts (%)	
		Chroma	Hue
1	93	-3%	-2%
2	96	-2%	0%
3	96	-2%	1%
4	97	-1%	0%
5	95	-3%	0%
6	98	0%	0%
7	98	0%	0%
8	95	-2%	0%
9	95	-2%	3%
10	93	-1%	5%
11	89	1%	6%
12	97	2%	1%
13	94	4%	-2%
14	93	1%	-4%
15	86	6%	-11%
16	94	-1%	-3%

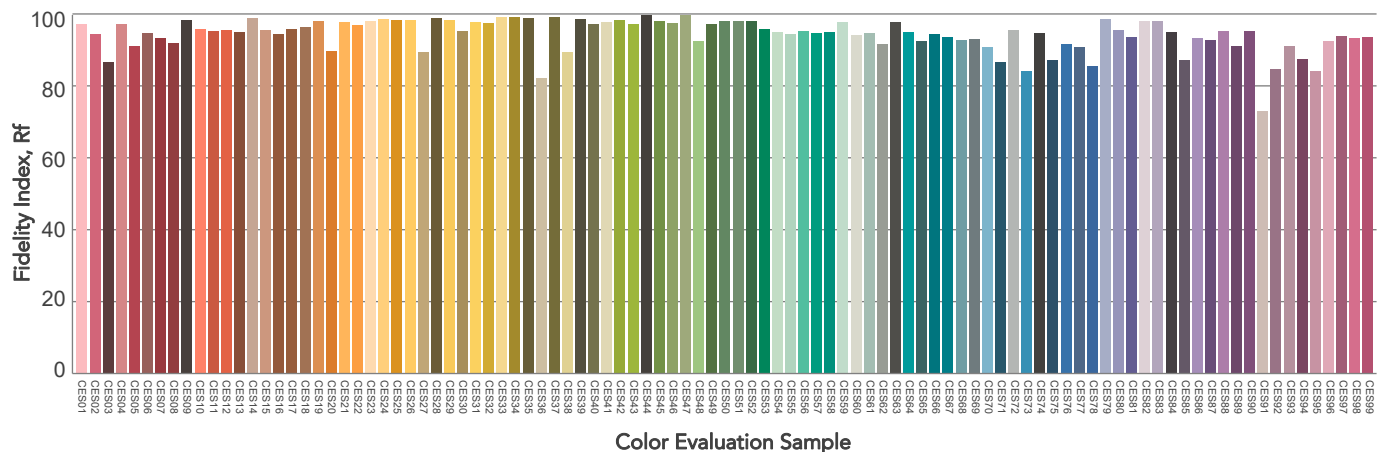
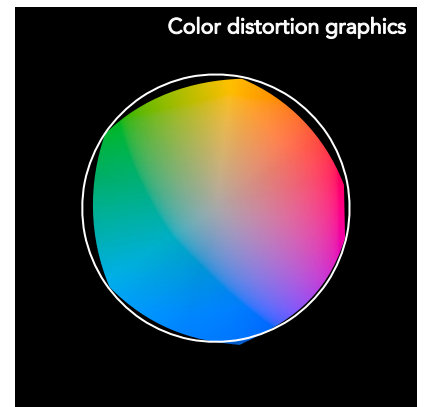
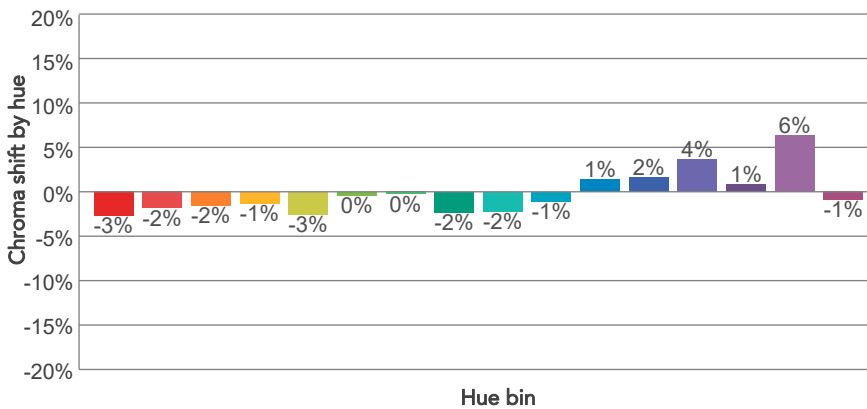
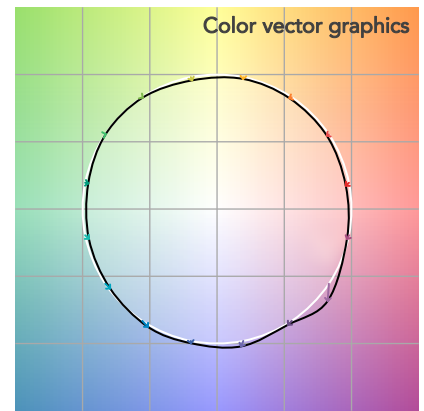
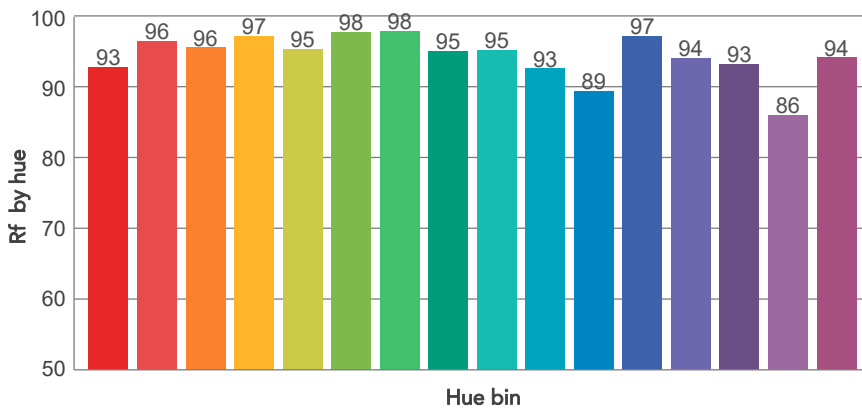
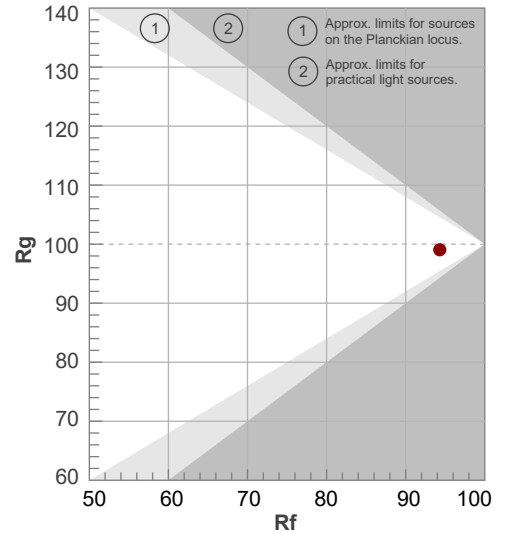

BEAM DETAILS



Beam angle 50%	Field angle 10%	Cut off angle 2,5%	Intensity ratio in 120° cone	Intensity ratio in 90° cone
35,3°	36,7°	36,9°	99,8%	99,8%

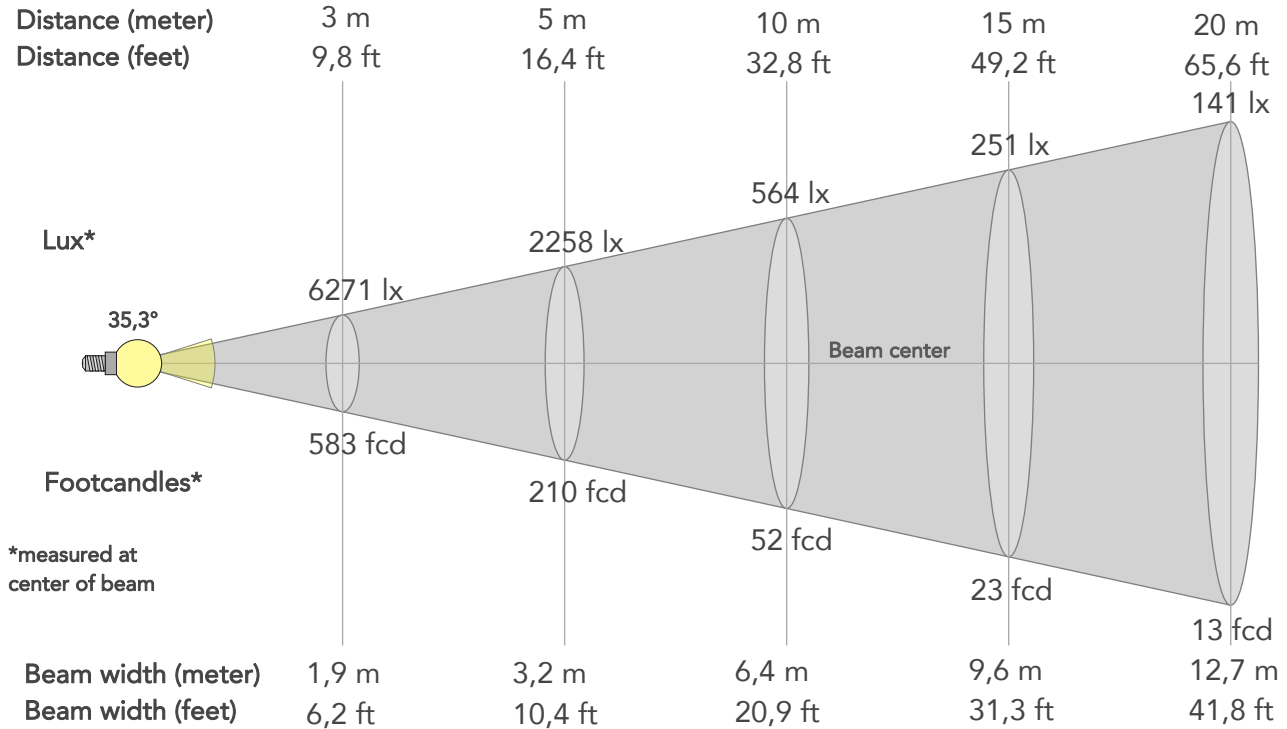

BEAM INTENSITIES AND WIDTHS

Distance	1m	2m	3m	4m	5m	7,5m	10m	15m	20m	25m	30m	40m	50m
Distance	3,3ft	6,6ft	9,8ft	13,1ft	16,4ft	24,6ft	32,8ft	49,2ft	65,6ft	82ft	98,4ft	131,2ft	164ft
Lux	56439lx	14110lx	6271lx	3527lx	2258lx	1003lx	564lx	251lx	141lx	90lx	63lx	35lx	23lx
Footcand.	5243fcd	1311fcd	583fcd	328fcd	210fcd	93fcd	52fcd	23fcd	13fcd	8fcd	6fcd	3fcd	2fcd
Beam wid.	0,6m	1,3m	1,9m	2,5m	3,2m	4,8m	6,4m	9,6m	12,7m	15,9m	19,1m	25,5m	31,9m
Beam wid.	2,1ft	4,2ft	6,2ft	8,3ft	10,4ft	15,7ft	20,9ft	31,3ft	41,8ft	52,2ft	62,7ft	83,6ft	104,5ft

LINEAR DISTRIBUTION DIAGRAM

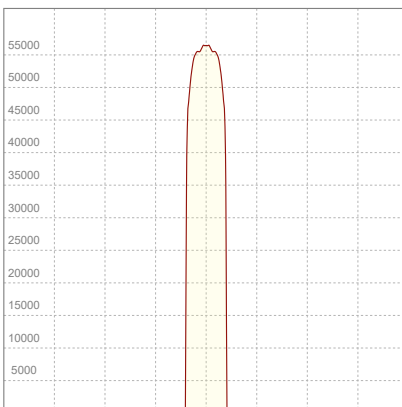

ELECTRICAL SPECIFICATIONS

Input voltage	Input current	Input power	Power FC	Efficiency
225V	1,75A	380,7W	0,96	41lm/W

ISO DIAGRAMS

ISO CANDELA DIAGRAM

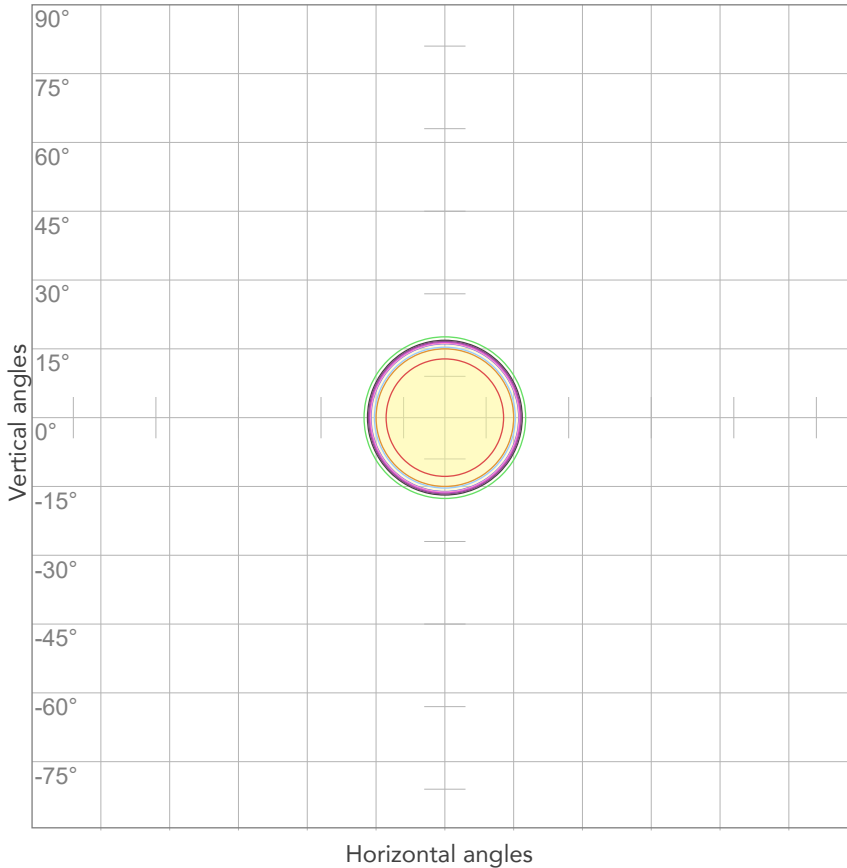

10%	5644 cd
20%	11288 cd
30%	16932 cd
40%	22575 cd
50%	28219 cd
60%	33863 cd
70%	39507 cd
80%	45151 cd

Conditions:

Number of c-planes: 2

Candela at center: 56439 cd

ISO LUX DIAGRAM

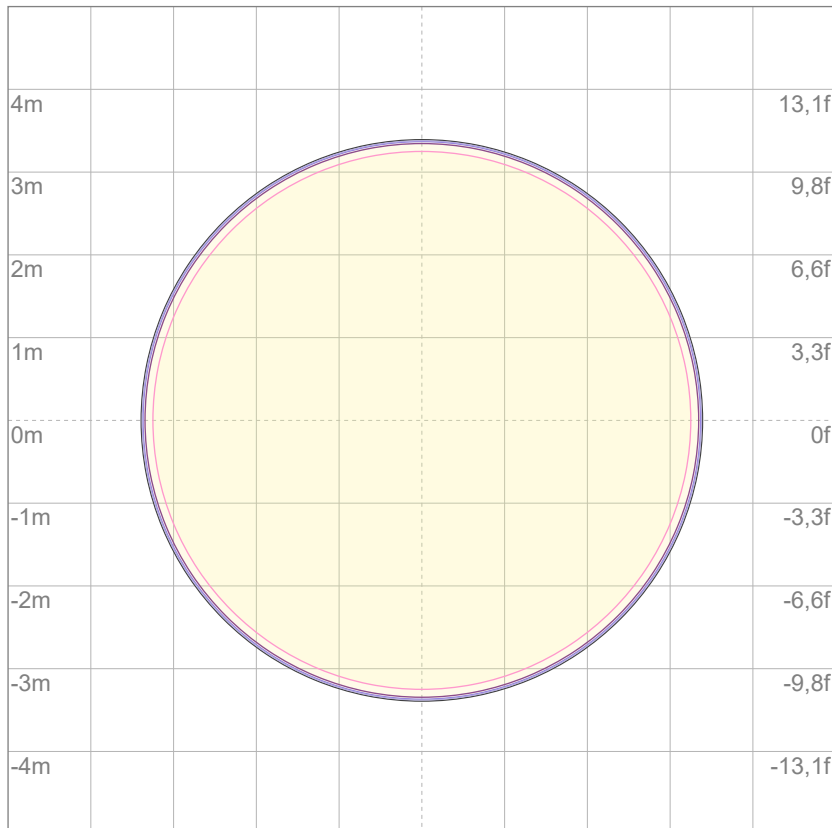

Mounting height: 10 meters (33 feet)

3%	16,9 lx
5%	28,2 lx
10%	56,4 lx
30%	169 lx
50%	282 lx

Conditions:

Number of c-planes: 2

Lux at center: 564 lx

Lux distribution on a surface when lamp is mounted at 10 meters from the surface.



Total lumen output:

13489 lm

Peak candela output:

48192 cd

Light quality:

CRI: 97,6

Color temperature:

2777 K

PRODUCT NAME:

ECLFWHPVW

MEASURAMENT CONDITIONS:

Beam angle:

PRL36

Target:

2800K

Operator:

Giuseppe della Peruta

Date and time:

08/01/2026 16:11:21

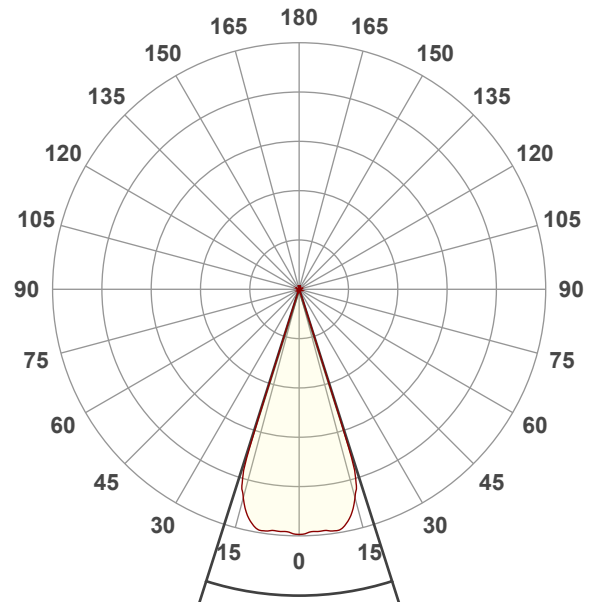

Beam angle 50%: 35,3°

Field angle 10%: 36,6°

Cut off angle 2.5%: 38°

Spectra

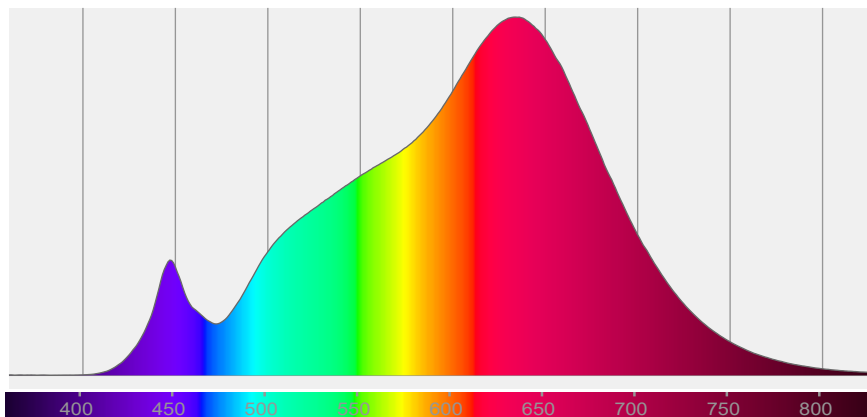

COLOR DETAILS

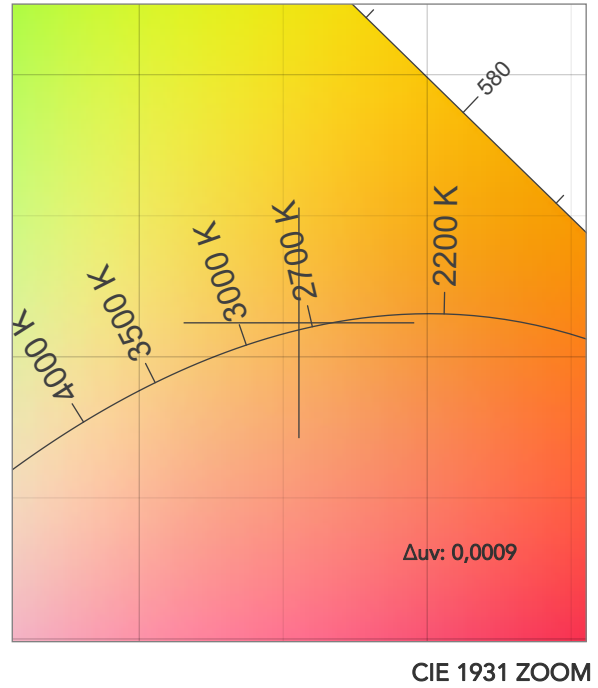
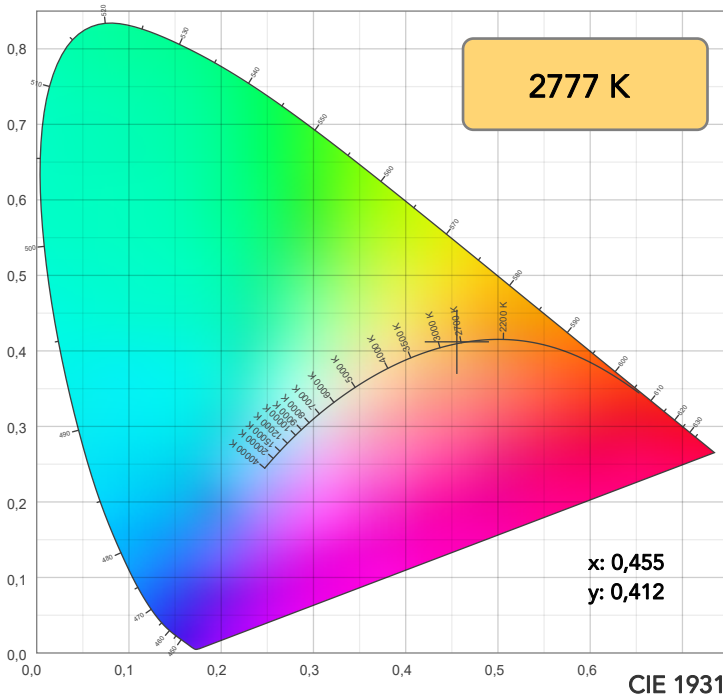

TM30: 95,8

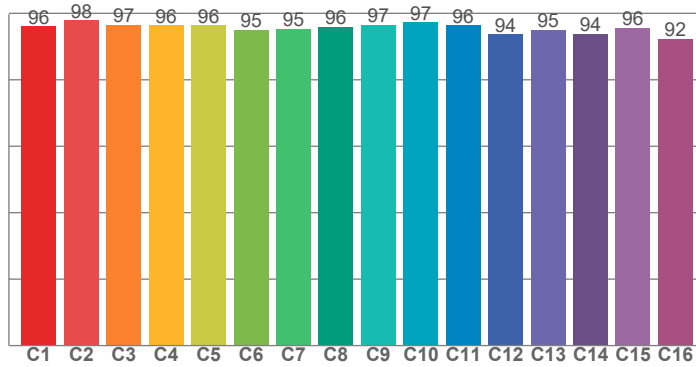

CRI: 97,6 (R1-R8)

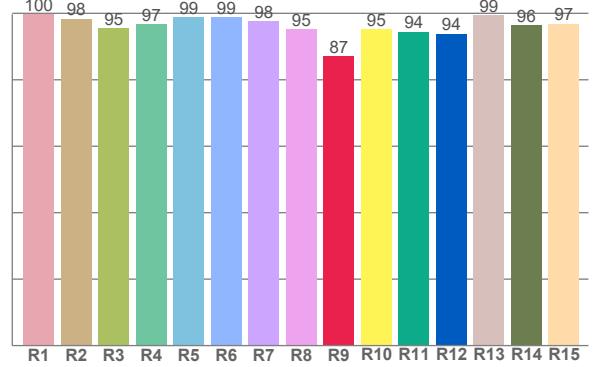

CQS: 94,7

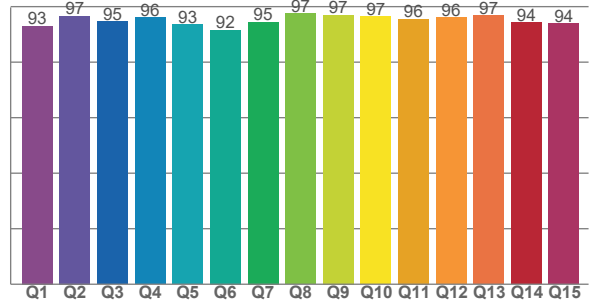

CRI R values, only R1-R8 are used to calculate final CRI value

R1	R2	R3	R4	R5	R6	R7	R8	R9	R10	R11	R12	R13	R14	R15
99,7	98,4	95,4	96,8	98,9	98,8	97,7	95,2	87,0	95,3	94,5	93,9	99,4	96,5	96,9

TM30 C values, 16 binned values out of total of 99 C values

C1	C2	C3	C4	C5	C6	C7	C8	C9	C10	C11	C12	C13	C14	C15	C16
96,1	98,0	96,6	96,4	96,4	95,0	95,3	96,0	96,6	97,2	96,4	93,8	95,1	93,8	95,6	92,4

CQS Q values

Q1	Q2	Q3	Q4	Q5	Q6	Q7	Q8	Q9	Q10	Q11	Q12	Q13	Q14	Q15
93,1	96,6	94,6	96,1	93,5	91,6	94,5	97,5	97,0	96,5	95,6	96,0	96,8	94,4	93,9

COLOR PARAMETERS

Color temperature	Color rendering index	Red component	Color fidelity	Color gamut	Color quality scale	Television lighting index	Color coordinate cie 1931	Color coordinate cie 1931	Color deviation from black body
CCT	CRI	CRI R9	TM30 Rf	TM30 Rg	CQS	TLCI	x	y	Δuv
2777 K	97,6	87,0	95,8	101,8	94,7	97	0,455	0,412	0,0009

TM30 DETAILS

Rf 95,8
Fidelity index Rf

Rg 101,8
Gammut index

Hue Bin	R _f	Graphic shifts (%)	
		Chroma	Hue
1	96	-1%	-1%
2	98	-1%	0%
3	97	0%	2%
4	96	0%	1%
5	96	2%	2%
6	95	3%	1%
7	95	2%	-2%
8	96	2%	-2%
9	97	0%	-2%
10	97	-1%	-1%
11	96	0%	2%
12	94	3%	0%
13	95	2%	-3%
14	94	3%	-4%
15	96	1%	-3%
16	92	0%	-6%

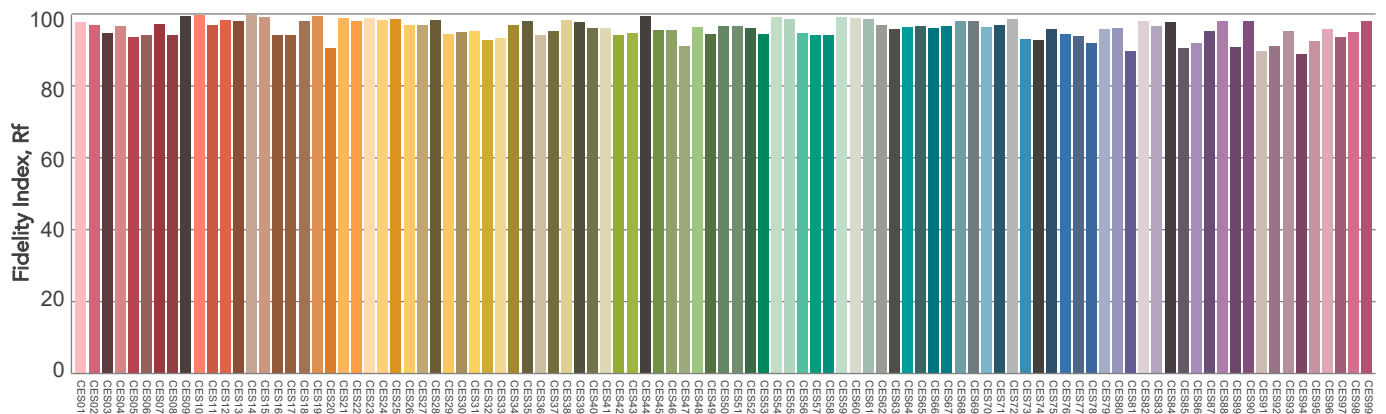
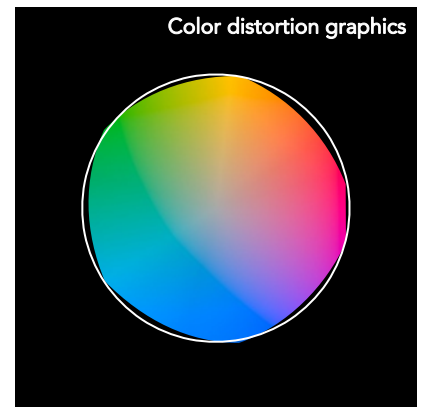
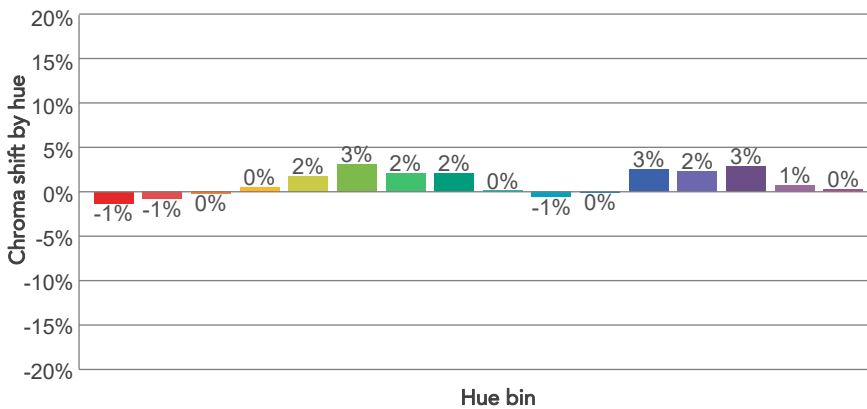
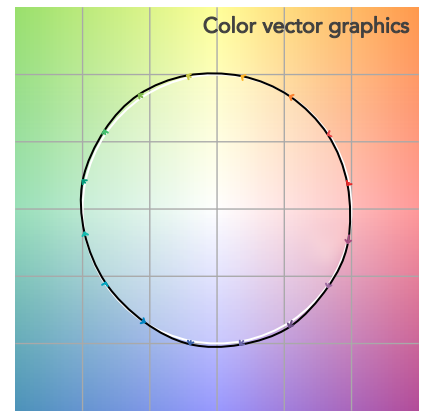
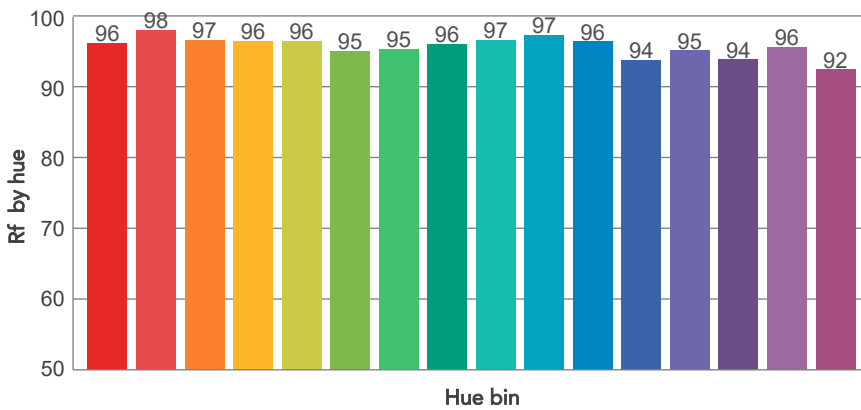
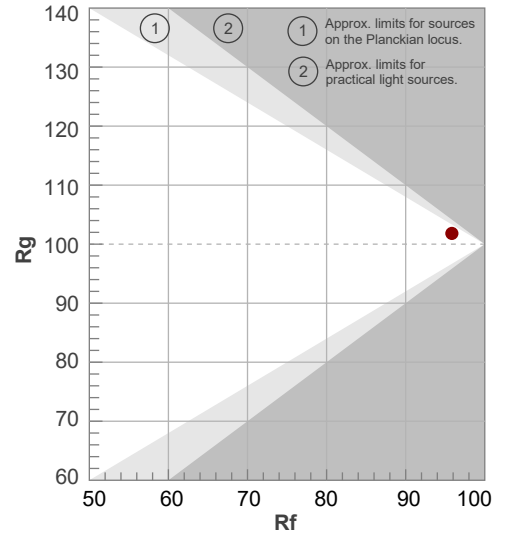

Color Evaluation Sample

BEAM DETAILS



Beam angle 50%	Field angle 10%	Cut off angle 2,5%	Intensity ratio in 120° cone	Intensity ratio in 90° cone
35,3°	36,6°	38°	99,8%	99,8%

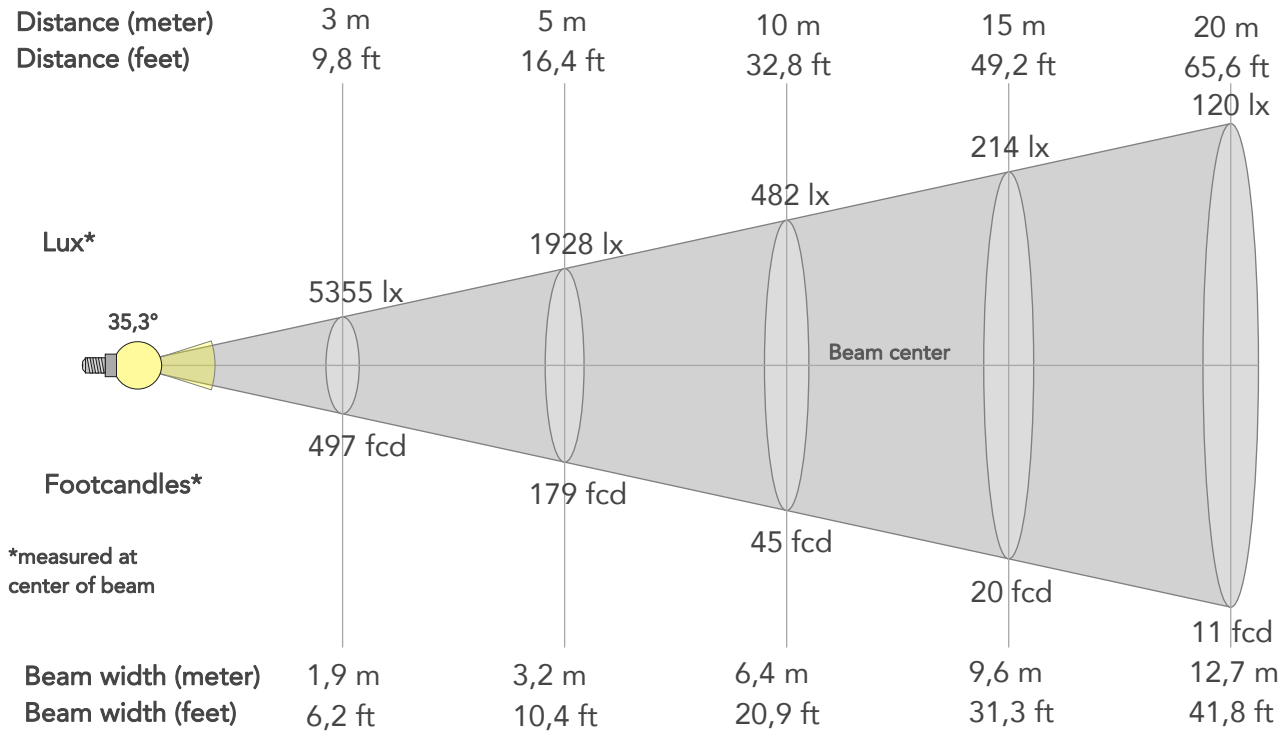

BEAM INTENSITIES AND WIDTHS

Distance	1m	2m	3m	4m	5m	7,5m	10m	15m	20m	25m	30m	40m	50m
Distance	3,3ft	6,6ft	9,8ft	13,1ft	16,4ft	24,6ft	32,8ft	49,2ft	65,6ft	82ft	98,4ft	131,2ft	164ft
Lux	48192lx	12048lx	5355lx	3012lx	1928lx	857lx	482lx	214lx	120lx	77lx	54lx	30lx	19lx
Footcand.	4477fcd	1119fcd	497fcd	280fcd	179fcd	80fcd	45fcd	20fcd	11fcd	7fcd	5fcd	3fcd	2fcd
Beam wid.	0,6m	1,3m	1,9m	2,5m	3,2m	4,8m	6,4m	9,6m	12,7m	15,9m	19,1m	25,5m	31,8m
Beam wid.	2,1ft	4,2ft	6,2ft	8,3ft	10,4ft	15,7ft	20,9ft	31,3ft	41,8ft	52,2ft	62,7ft	83,6ft	104,4ft

LINEAR DISTRIBUTION DIAGRAM

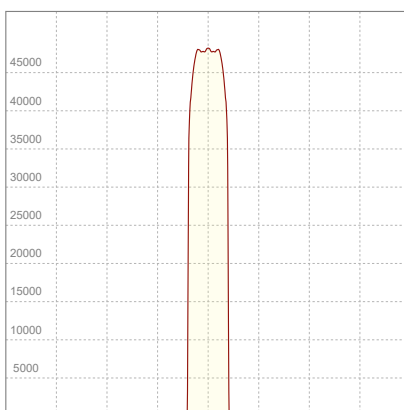

ELECTRICAL SPECIFICATIONS

Input voltage	Input current	Input power	Power FC	Efficiency
225V	1,89A	412,1W	0,97	33lm/W

ISO DIAGRAMS

ISO CANDELA DIAGRAM

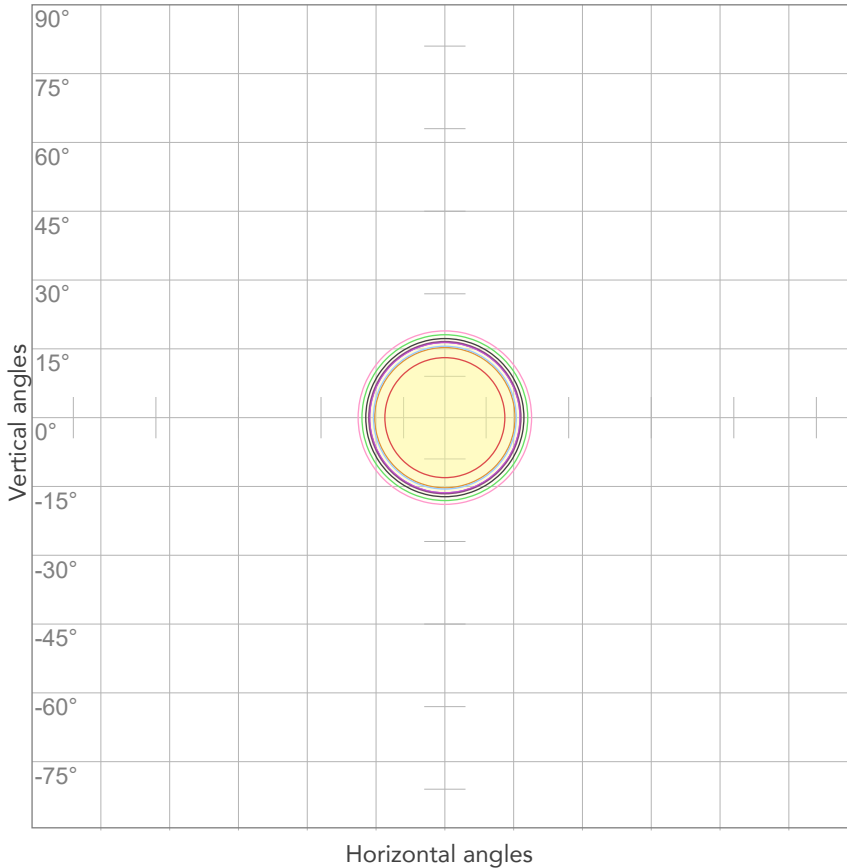

10%	4819 cd
20%	9638 cd
30%	14457 cd
40%	19277 cd
50%	24096 cd
60%	28915 cd
70%	33734 cd
80%	38553 cd

Conditions:

Number of c-planes: 2

Candela at center: 48192 cd

ISO LUX DIAGRAM

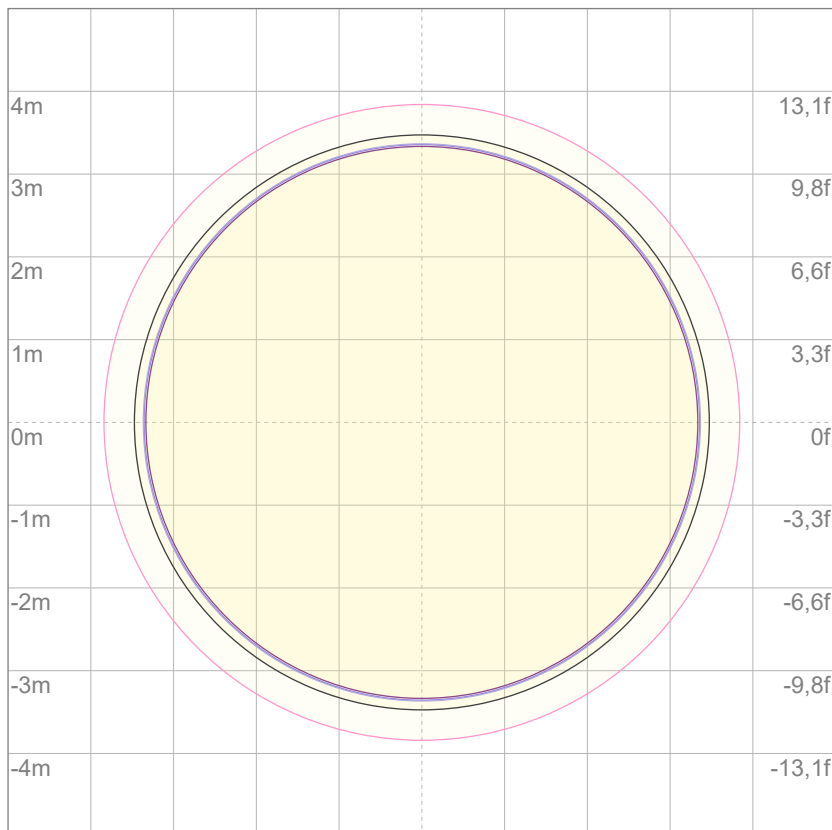

3%	14,5 lx
5%	24,1 lx
10%	48,2 lx
30%	145 lx
50%	241 lx

Conditions:

Number of c-planes: 2

Lux at center: 482 lx

Lux distribution on a surface when lamp is mounted at 10 meters from the surface.

Mounting height: 10 meters (33 feet)



Total lumen output:

15010 lm

Peak candela output:

53749 cd

Light quality:

CRI: 97,5

Color temperature:

3187 K

PRODUCT NAME:

ECLFWHPVW

MEASURAMENT CONDITIONS:

Beam angle:

PRL36

Target:

3200K

Operator:

Giuseppe della Peruta

Date and time:

08/01/2026 16:14:41

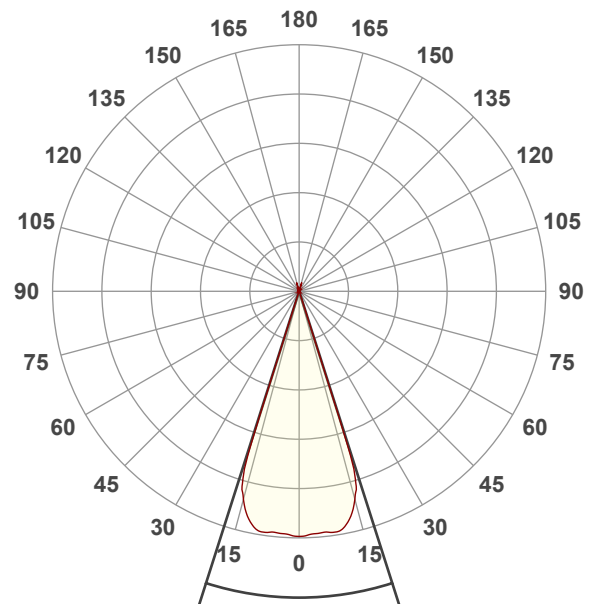

Beam angle 50%: 35,4°

Field angle 10%: 36,7°

Cut off angle 2.5%: 37,2°

Spectra

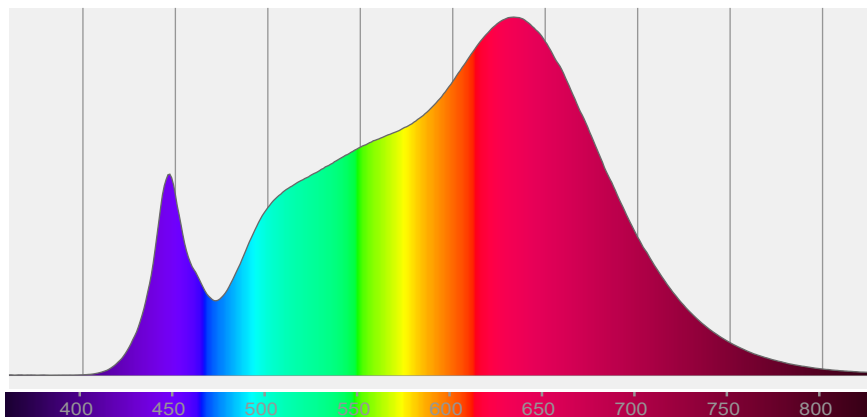

COLOR DETAILS

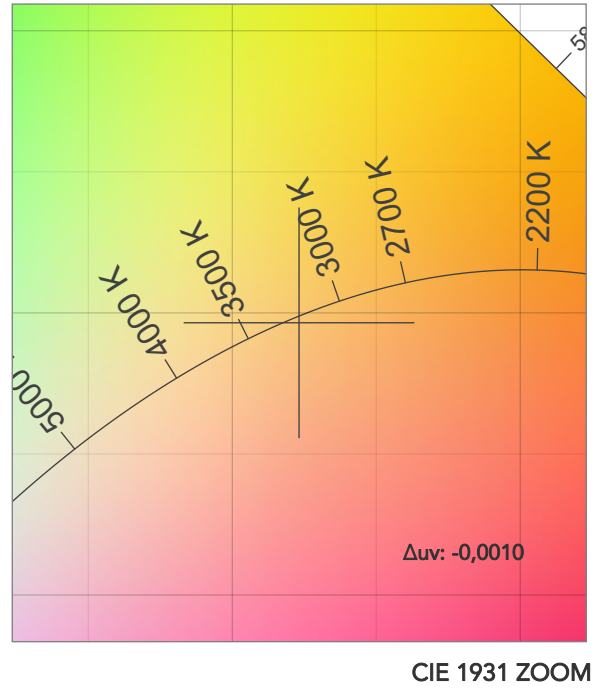
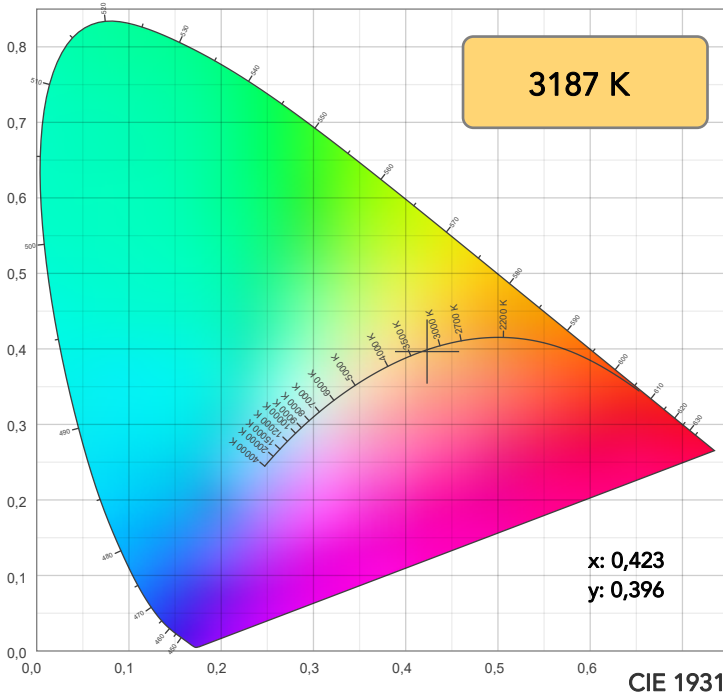

TM30: 95,9

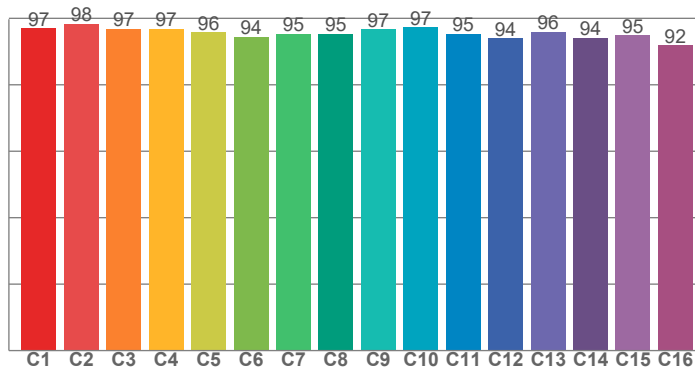

CRI: 97,5 (R1-R8)

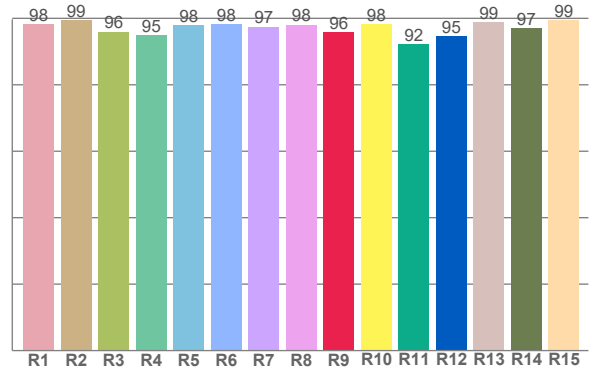

CRI R values, only R1-R8 are used to calculate final CRI value

R1	R2	R3	R4	R5	R6	R7	R8	R9	R10	R11	R12	R13	R14	R15
98,3	99,3	96,0	94,9	98,0	98,2	97,5	98,1	95,8	98,2	92,3	94,6	98,8	97,0	99,3

TM30 C values, 16 binned values out of total of 99 C values

C1	C2	C3	C4	C5	C6	C7	C8	C9	C10	C11	C12	C13	C14	C15	C16
96,9	98,3	96,8	96,9	95,7	94,4	95,3	95,4	96,8	97,3	95,3	93,9	95,9	94,1	94,8	91,8

CQS Q values

Q1	Q2	Q3	Q4	Q5	Q6	Q7	Q8	Q9	Q10	Q11	Q12	Q13	Q14	Q15
95,6	98,2	94,2	97,7	94,4	91,7	94,8	98,2	97,7	97,0	98,4	98,2	98,2	97,4	96,9

CQS: 95,8

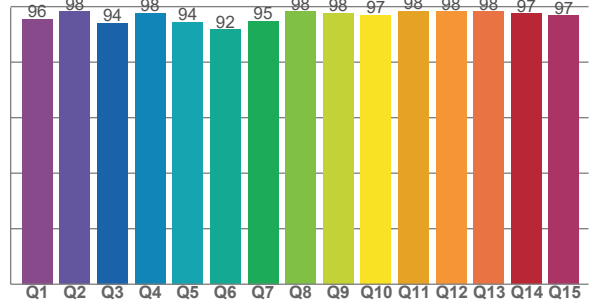

COLOR PARAMETERS

Color temperature	Color rendering index	Red component	Color fidelity	Color gamut	Color quality scale	Television lighting index	Color coordinate cie 1931	Color coordinate cie 1931	Color deviation from black body
CCT	CRI	CRI R9	TM30 Rf	TM30 Rg	CQS	TLCI	x	y	Δuv
3187 K	97,5	95,8	95,9	103,2	95,8	97	0,423	0,396	-0,0010

TM30 DETAILS

Rf 95,9
Fidelity index Rf

Rg 103,2
Gammut index

Hue Bin	R _f	Graphic shifts (%)	
		Chroma	Hue
1	97	0%	-1%
2	98	0%	0%
3	97	0%	1%
4	97	1%	1%
5	96	1%	2%
6	94	4%	1%
7	95	3%	-1%
8	95	2%	-2%
9	97	1%	-1%
10	97	0%	-1%
11	95	1%	3%
12	94	3%	0%
13	96	2%	-2%
14	94	4%	-3%
15	95	2%	-3%
16	92	2%	-6%

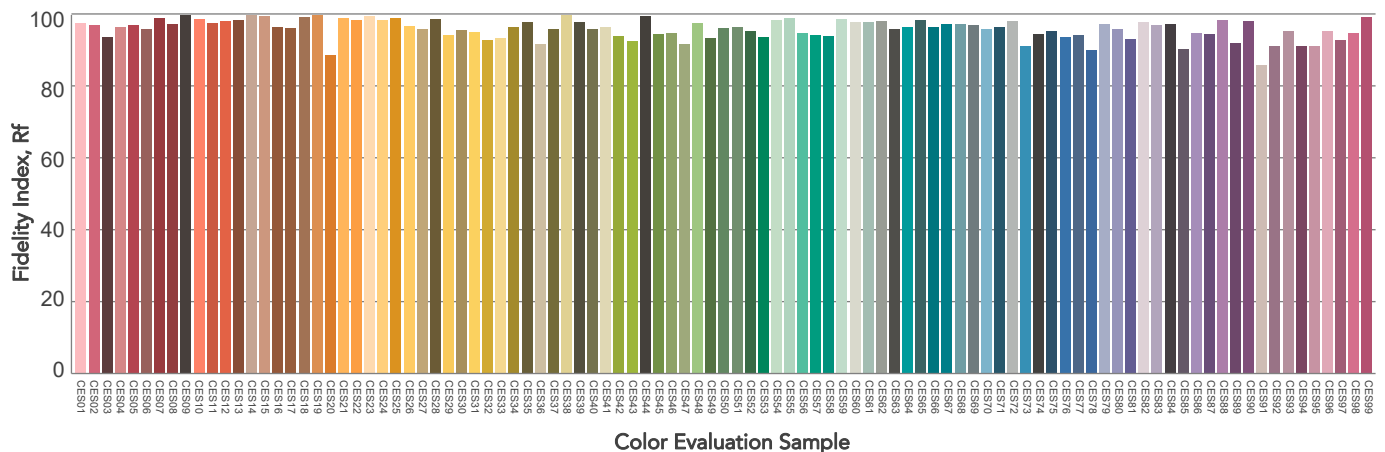
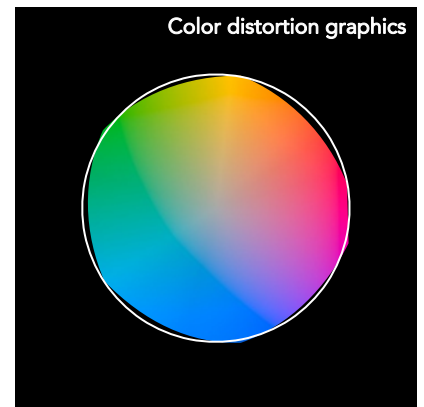
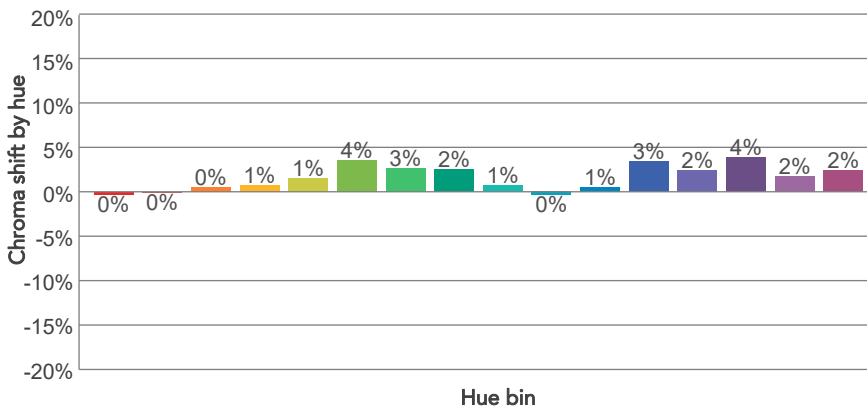
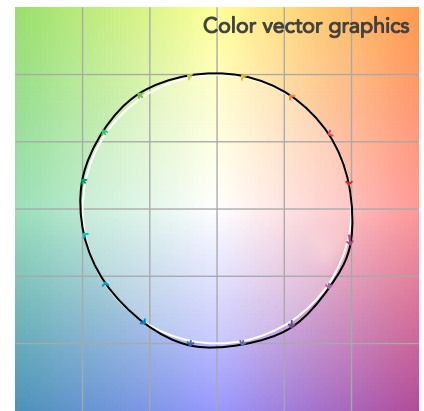
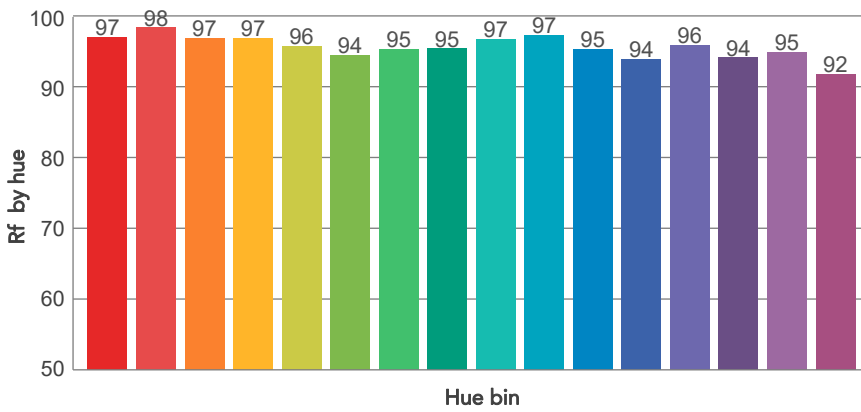
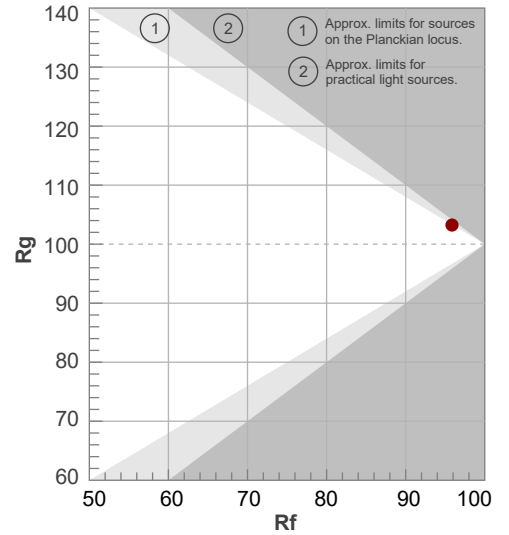

BEAM DETAILS



Beam angle 50%	Field angle 10%	Cut off angle 2,5%	Intensity ratio in 120° cone	Intensity ratio in 90° cone
35,4°	36,7°	37,2°	99,8%	99,8%

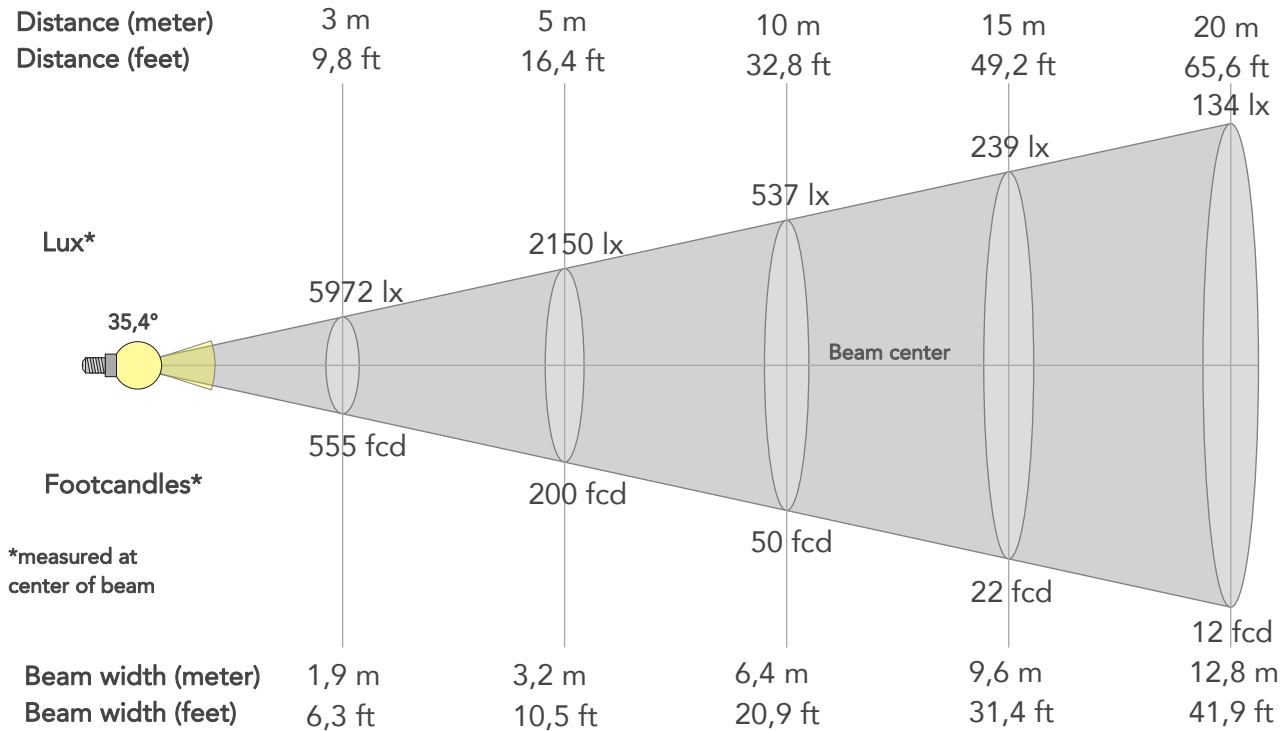

BEAM INTENSITIES AND WIDTHS

Distance	1m	2m	3m	4m	5m	7,5m	10m	15m	20m	25m	30m	40m	50m
Distance	3,3ft	6,6ft	9,8ft	13,1ft	16,4ft	24,6ft	32,8ft	49,2ft	65,6ft	82ft	98,4ft	131,2ft	164ft
Lux	53749lx	13437lx	5972lx	3359lx	2150lx	956lx	537lx	239lx	134lx	86lx	60lx	34lx	21lx
Footcand.	4993fcd	1248fcd	555fcd	312fcd	200fcd	89fcd	50fcd	22fcd	12fcd	8fcd	6fcd	3fcd	2fcd
Beam wid.	0,6m	1,3m	1,9m	2,6m	3,2m	4,8m	6,4m	9,6m	12,8m	16m	19,1m	25,5m	31,9m
Beam wid.	2,1ft	4,2ft	6,3ft	8,4ft	10,5ft	15,7ft	20,9ft	31,4ft	41,9ft	52,3ft	62,8ft	83,7ft	104,7ft

LINEAR DISTRIBUTION DIAGRAM

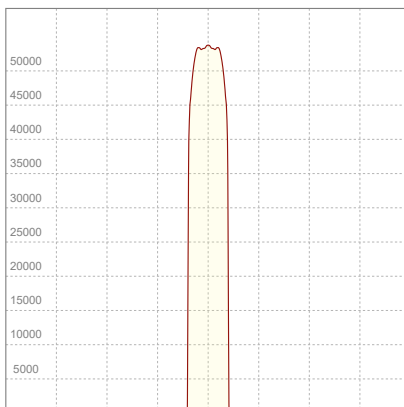

ELECTRICAL SPECIFICATIONS

Input voltage	Input current	Input power	Power FC	Efficiency
225V	2,00A	437,8W	0,97	34lm/W

ISO DIAGRAMS

ISO CANDELA DIAGRAM

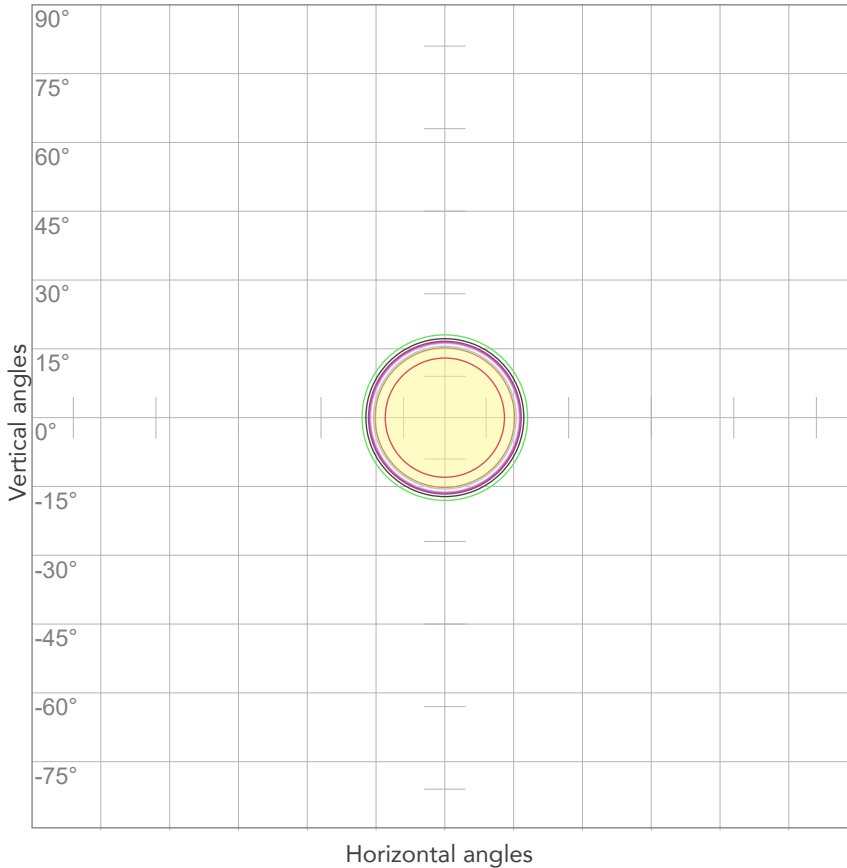

10%	5375 cd
20%	10750 cd
30%	16125 cd
40%	21499 cd
50%	26874 cd
60%	32249 cd
70%	37624 cd
80%	42999 cd

Conditions:

Number of c-planes: 2

Candela at center: 53749 cd

ISO LUX DIAGRAM

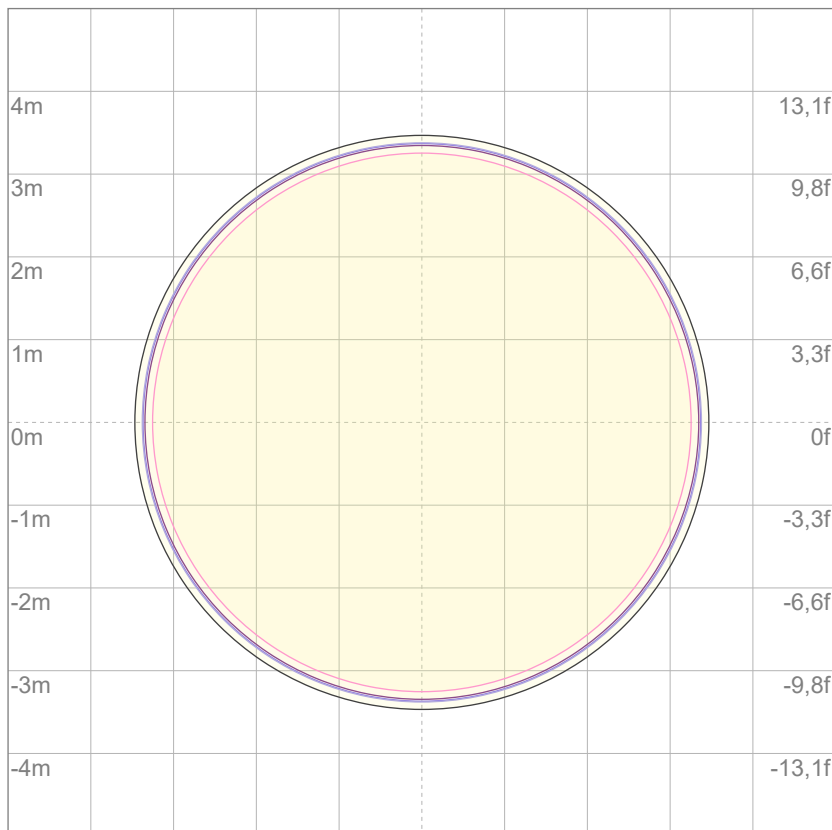

Mounting height: 10 meters (33 feet)

3%	16,1 lx
5%	26,9 lx
10%	53,7 lx
30%	161 lx
50%	269 lx

Conditions:

Number of c-planes: 2

Lux at center: 537 lx

Lux distribution on a surface when lamp is mounted at 10 meters from the surface.



Total lumen output:

16118 lm

Peak candela output:

57947 cd

Light quality:

CRI: 97,5

Color temperature:

3992 K

PRODUCT NAME:

ECLFWHPVW

MEASURAMENT CONDITIONS:

Beam angle:

PRL36

Target:

3200K

Operator:

Giuseppe della Peruta

Date and time:

08/01/2026 16:19:32

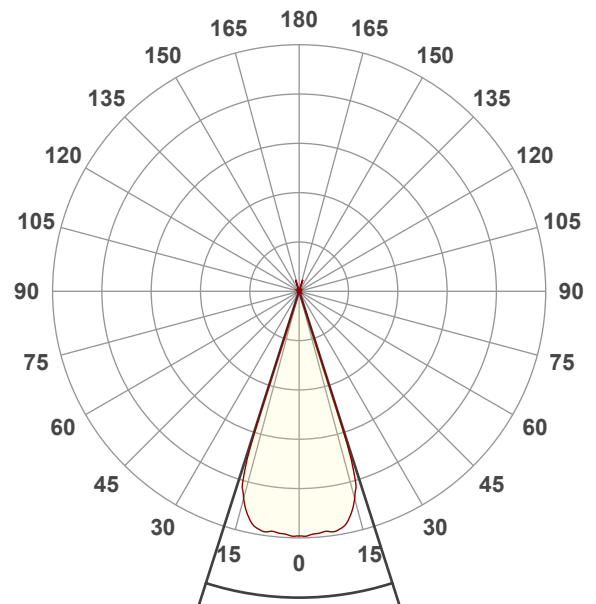

Beam angle 50%: 35,4°

Field angle 10%: 36,8°

Cut off angle 2.5%: 37°

Spectra

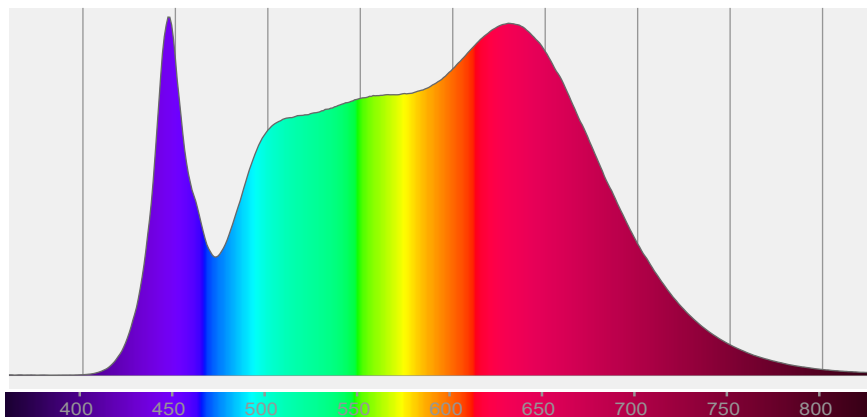

COLOR DETAILS

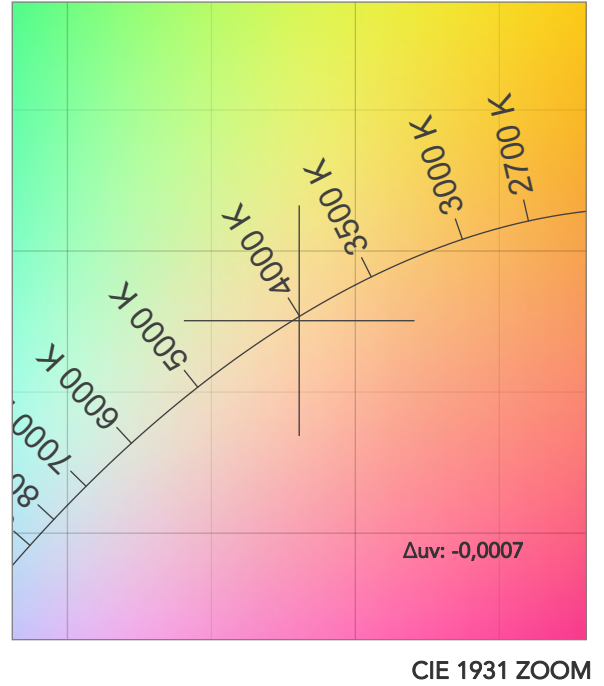
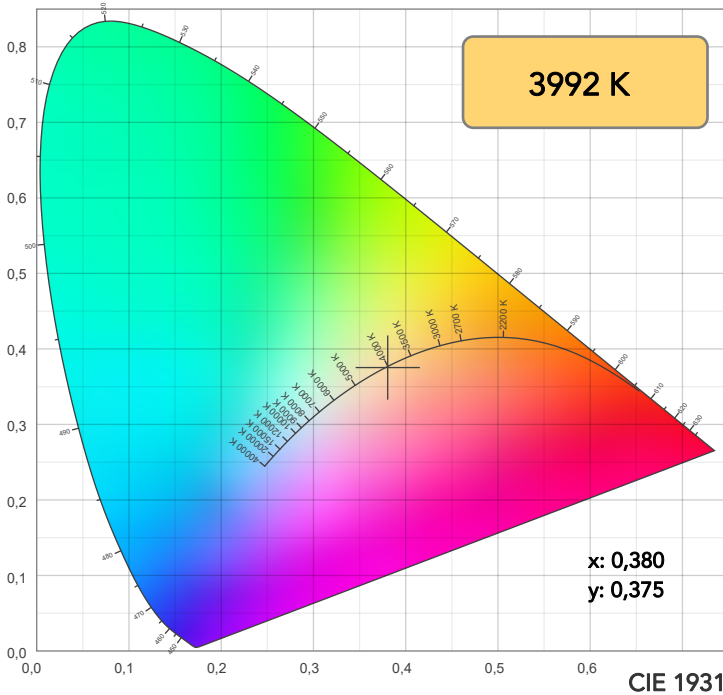

TM30: 96,1

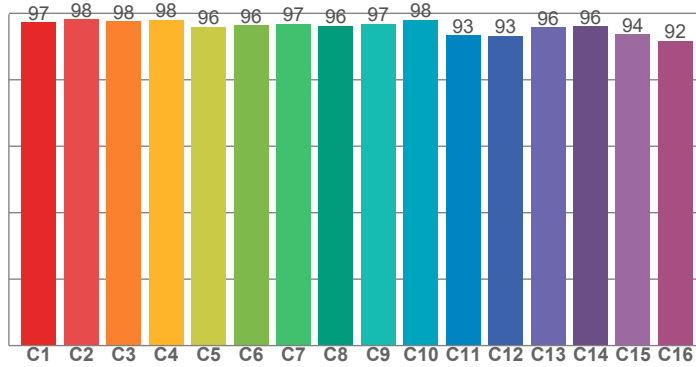

CRI: 97,5 (R1-R8)

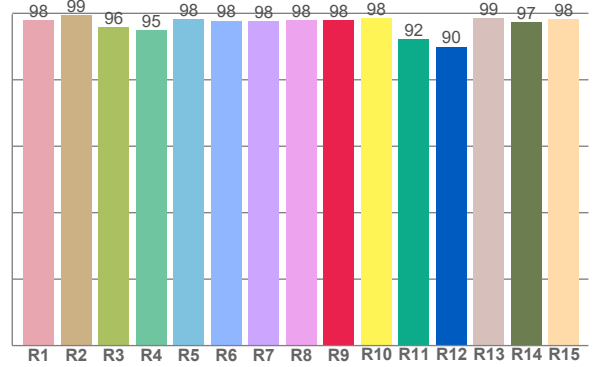

CRI R values, only R1-R8 are used to calculate final CRI value

R1	R2	R3	R4	R5	R6	R7	R8	R9	R10	R11	R12	R13	R14	R15
98,0	99,4	95,9	94,9	98,2	97,8	97,6	97,9	98,0	98,5	92,3	90,0	98,6	97,3	98,4

TM30 C values, 16 binned values out of total of 99 C values

C1	C2	C3	C4	C5	C6	C7	C8	C9	C10	C11	C12	C13	C14	C15	C16
97,3	98,2	97,7	98,1	96,0	96,5	96,9	96,3	96,8	98,0	93,4	93,3	95,7	96,1	93,7	91,7

CQS Q values

Q1	Q2	Q3	Q4	Q5	Q6	Q7	Q8	Q9	Q10	Q11	Q12	Q13	Q14	Q15
99,4	99,4	94,3	98,0	97,1	95,0	97,8	99,2	98,6	98,8	99,5	98,8	98,8	99,2	99,6

CQS: 97,6

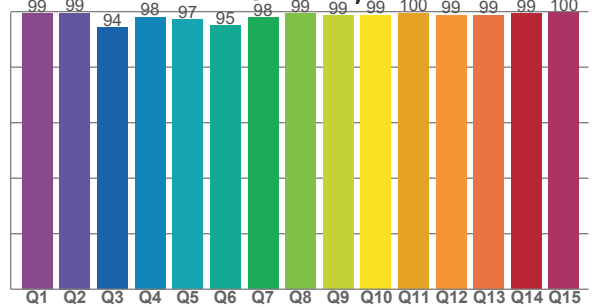

COLOR PARAMETERS

Color temperature	Color rendering index	Red component	Color fidelity	Color gamut	Color quality scale	Television lighting index	Color coordinate cie 1931	Color coordinate cie 1931	Color deviation from black body
CCT	CRI	CRI R9	TM30 Rf	TM30 Rg	CQS	TLCI	x	y	Δuv
3992 K	97,5	98,0	96,1	102,7	97,6	98	0,380	0,375	-0,0007

TM30 DETAILS

Rf 96,1
Fidelity index Rf

Rg 102,7
Gammut index

Hue Bin	R _f	Graphic shifts (%)	
		Chroma	Hue
1	97	0%	-1%
2	98	0%	-1%
3	98	0%	1%
4	98	0%	0%
5	96	0%	1%
6	96	2%	1%
7	97	2%	1%
8	96	1%	0%
9	97	1%	1%
10	98	0%	0%
11	93	2%	4%
12	93	3%	2%
13	96	3%	-1%
14	96	3%	0%
15	94	3%	-3%
16	92	3%	-5%

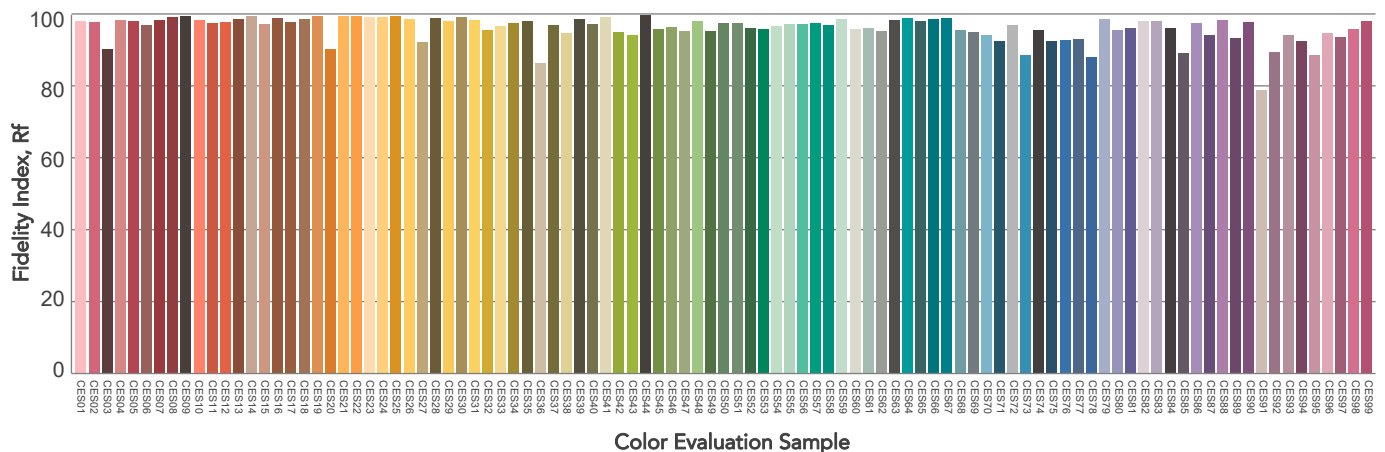
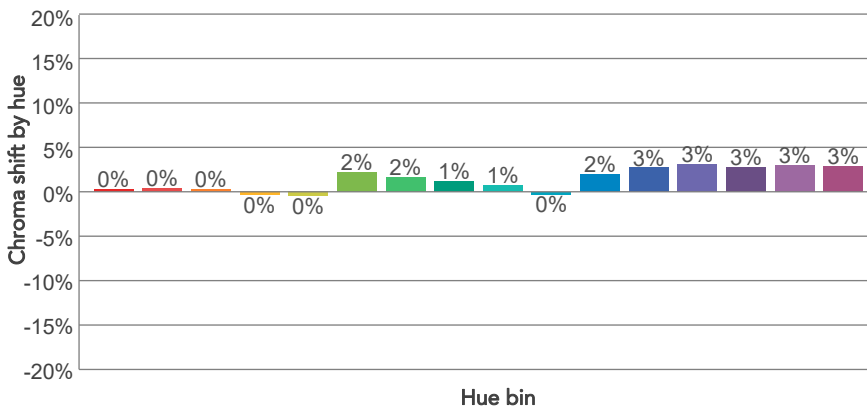
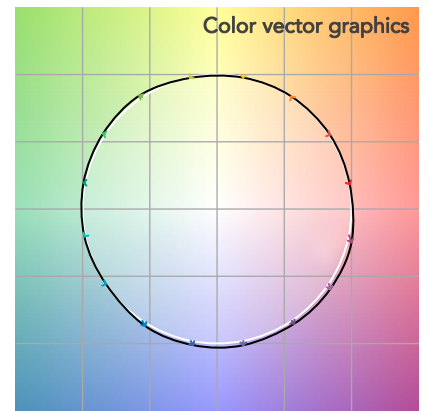
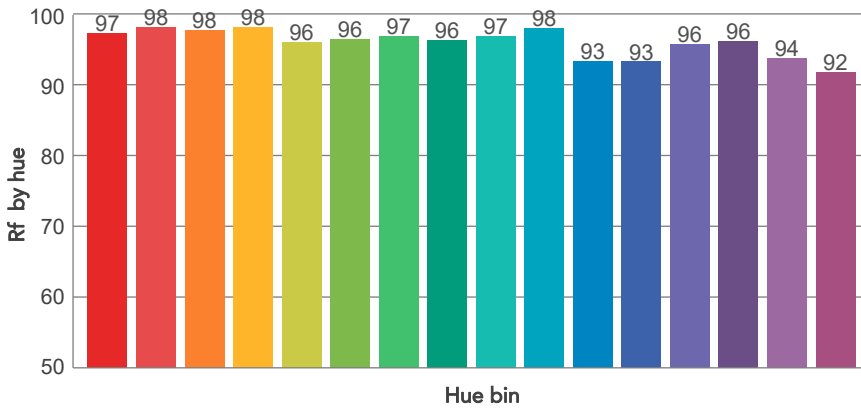
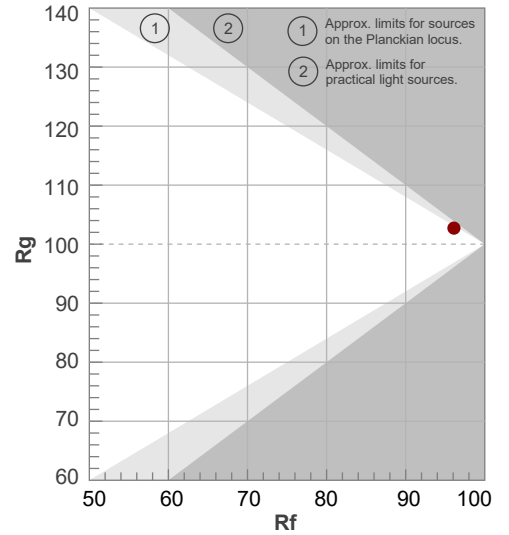

BEAM DETAILS



Beam angle 50%	Field angle 10%	Cut off angle 2,5%	Intensity ratio in 120° cone	Intensity ratio in 90° cone
35,4°	36,8°	37°	99,8%	99,8%

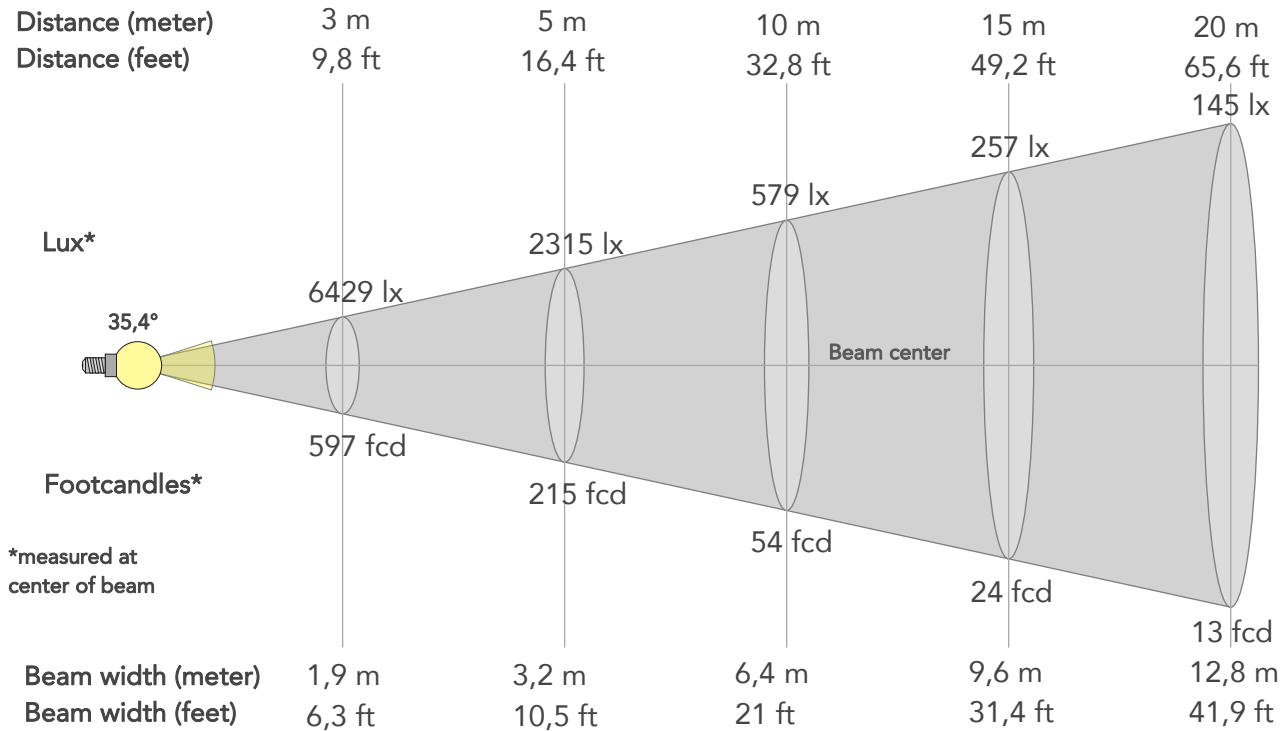

BEAM INTENSITIES AND WIDTHS

Distance	1m	2m	3m	4m	5m	7,5m	10m	15m	20m	25m	30m	40m	50m
Distance	3,3ft	6,6ft	9,8ft	13,1ft	16,4ft	24,6ft	32,8ft	49,2ft	65,6ft	82ft	98,4ft	131,2ft	164ft
Lux	57863lx	14466lx	6429lx	3616lx	2315lx	1029lx	579lx	257lx	145lx	93lx	64lx	36lx	23lx
Footcand.	5376fcd	1344fcd	597fcd	336fcd	215fcd	96fcd	54fcd	24fcd	13fcd	9fcd	6fcd	3fcd	2fcd
Beam wid.	0,6m	1,3m	1,9m	2,6m	3,2m	4,8m	6,4m	9,6m	12,8m	16m	19,2m	25,6m	32m
Beam wid.	2,1ft	4,2ft	6,3ft	8,4ft	10,5ft	15,7ft	21ft	31,4ft	41,9ft	52,4ft	62,9ft	83,9ft	104,8ft

LINEAR DISTRIBUTION DIAGRAM

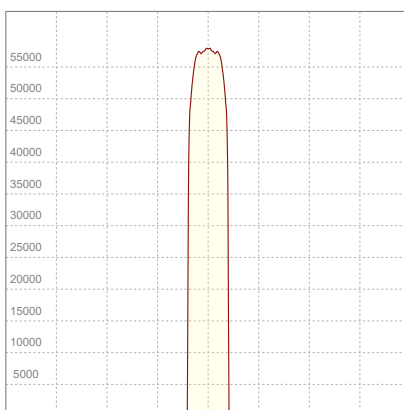

ELECTRICAL SPECIFICATIONS

Input voltage	Input current	Input power	Power FC	Efficiency
226V	2,02A	441,1W	0,97	37lm/W

ISO DIAGRAMS

ISO CANDELA DIAGRAM

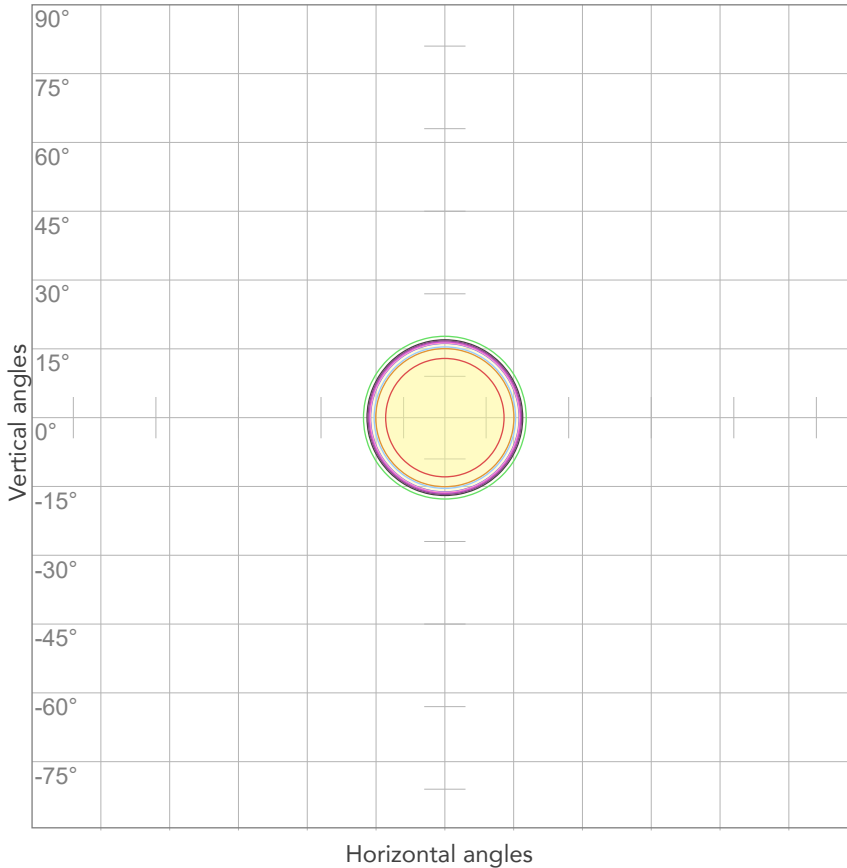

10%	5786 cd
20%	11573 cd
30%	17359 cd
40%	23145 cd
50%	28932 cd
60%	34718 cd
70%	40504 cd
80%	46290 cd

Conditions:

Number of c-planes: 2

Candela at center: 57863 cd

ISO LUX DIAGRAM

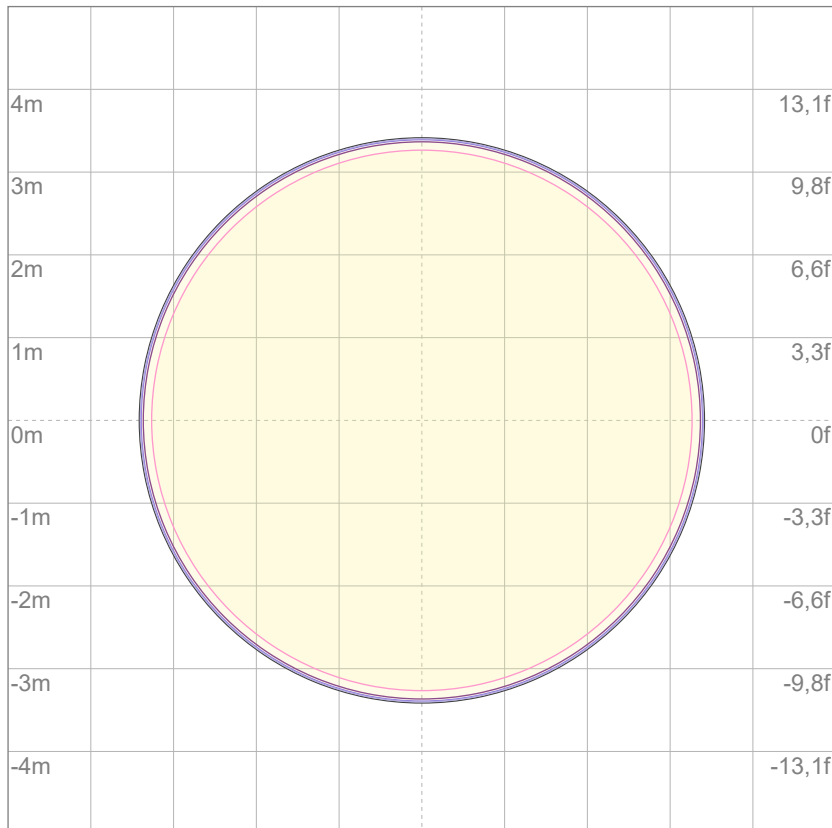

Mounting height: 10 meters (33 feet)

3%	17,4 lx
5%	28,9 lx
10%	57,9 lx
30%	174 lx
50%	289 lx

Conditions:

Number of c-planes: 2

Lux at center: 579 lx

Lux distribution on a surface when lamp is mounted at 10 meters from the surface.



Total lumen output:

17248 lm

Peak candela output:

62304 cd

Light quality:

CRI: 97,0

Color temperature:

5595 K

PRODUCT NAME:

ECLFWHPVW

MEASURAMENT CONDITIONS:

Beam angle:

PRL36

Target:

3200K

Operator:

Giuseppe della Peruta

Date and time:

08/01/2026 16:23:24

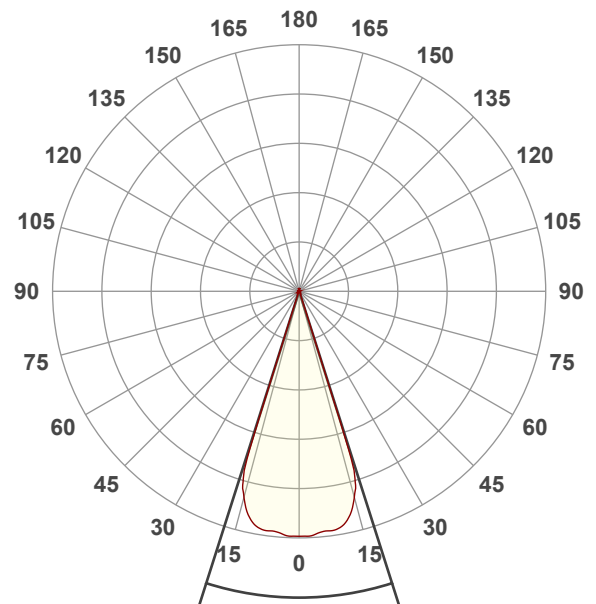

Beam angle 50%: 35,3°

Field angle 10%: 36,6°

Cut off angle 2.5%: 38°

Spectra

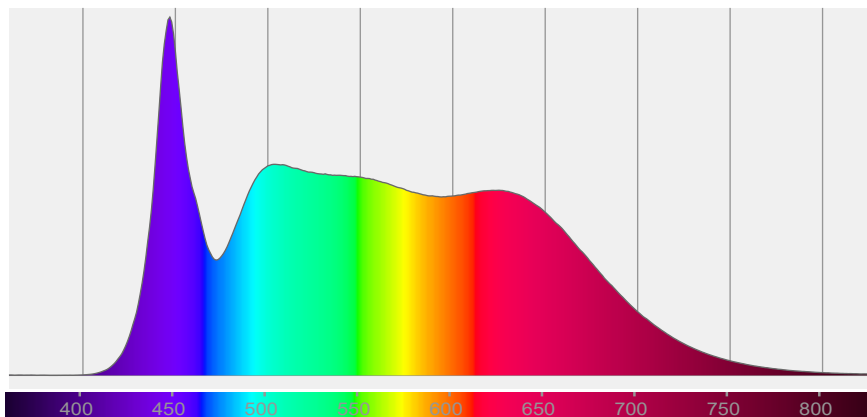

COLOR DETAILS

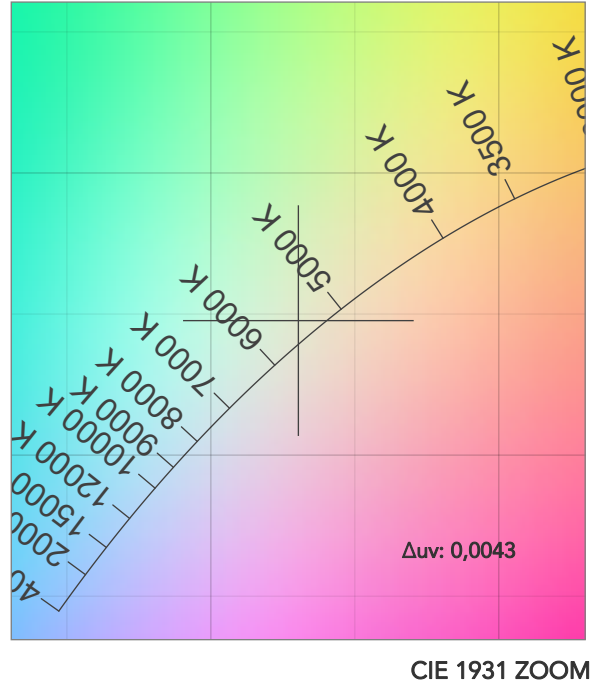
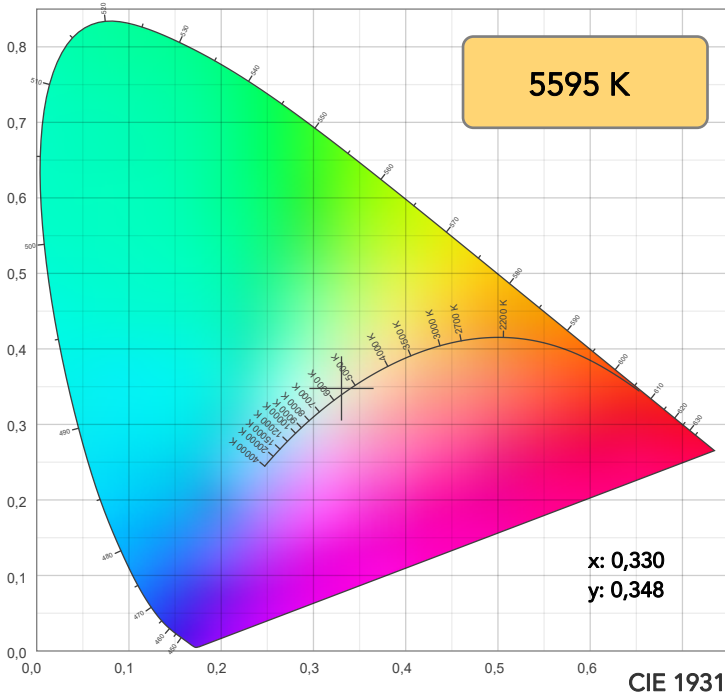

TM30: 95,7

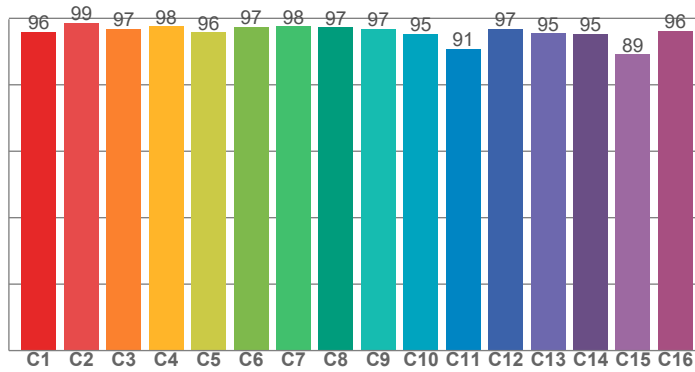

CRI: 97,0 (R1-R8)

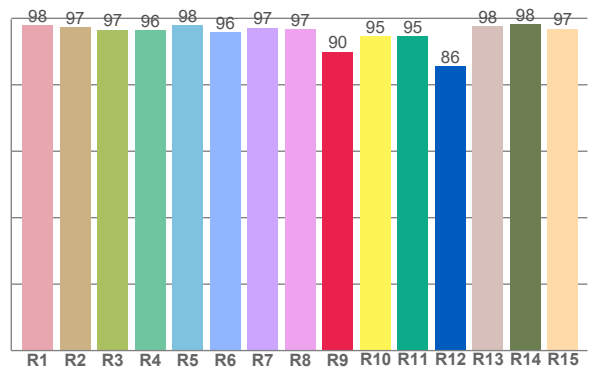

CRI R values, only R1-R8 are used to calculate final CRI value

R1	R2	R3	R4	R5	R6	R7	R8	R9	R10	R11	R12	R13	R14	R15
98,0	97,3	96,6	96,4	97,9	95,9	97,2	96,6	90,0	94,5	94,7	85,7	97,7	98,3	96,9

TM30 C values, 16 binned values out of total of 99 C values

C1	C2	C3	C4	C5	C6	C7	C8	C9	C10	C11	C12	C13	C14	C15	C16
95,9	98,6	96,8	97,5	95,9	97,5	97,5	97,2	96,8	95,4	90,8	96,8	95,5	95,3	89,2	96,2

CQS Q values

Q1	Q2	Q3	Q4	Q5	Q6	Q7	Q8	Q9	Q10	Q11	Q12	Q13	Q14	Q15
97,7	99,2	92,9	95,7	97,8	96,0	97,6	99,5	99,4	98,1	99,0	98,9	99,1	97,2	97,4

CQS: 97,1

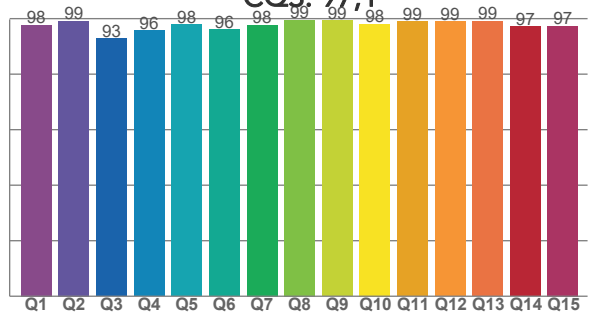

COLOR PARAMETERS

Color temperature	Color rendering index	Red component	Color fidelity	Color gamut	Color quality scale	Television lighting index	Color coordinate cie 1931	Color coordinate cie 1931	Color deviation from black body
CCT	CRI	CRI R9	TM30 Rf	TM30 Rg	CQS	TLCI	x	y	Δuv
5595 K	97,0	90,0	95,7	101,4	97,1	99	0,330	0,348	0,0043

TM30 DETAILS

Rf 95,7
Fidelity index Rf

Rg 101,4
Gammut index

Hue Bin	R _f	Graphic shifts (%)	
		Chroma	Hue
1	96	-1%	-1%
2	99	-1%	0%
3	97	-1%	1%
4	98	-1%	0%
5	96	-1%	1%
6	97	1%	1%
7	98	1%	0%
8	97	-1%	0%
9	97	-1%	2%
10	95	-1%	3%
11	91	2%	6%
12	97	2%	1%
13	95	4%	-1%
14	95	2%	-2%
15	89	7%	-8%
16	96	0%	-2%

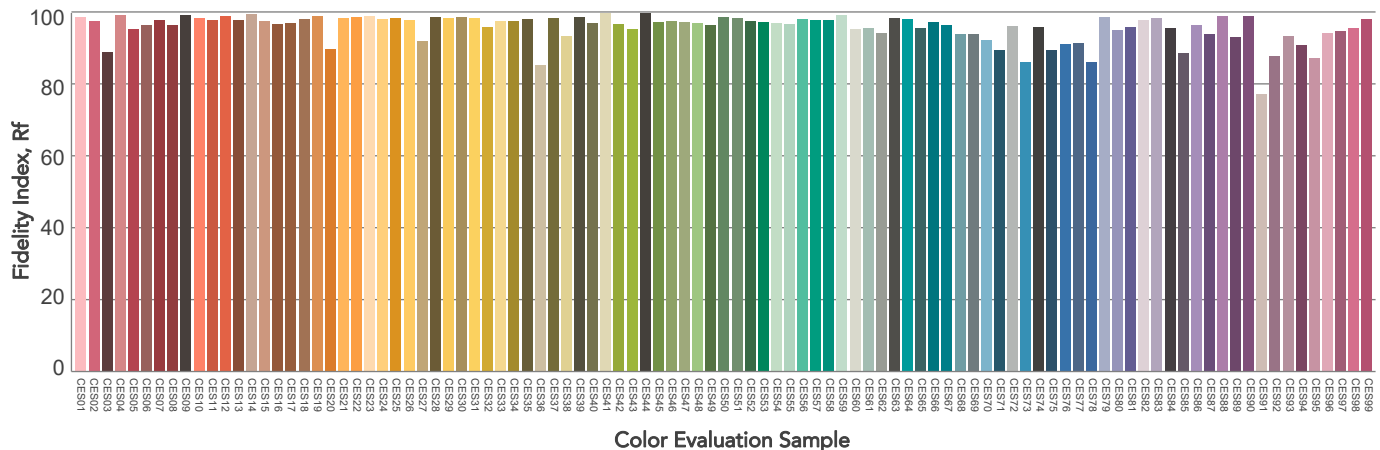
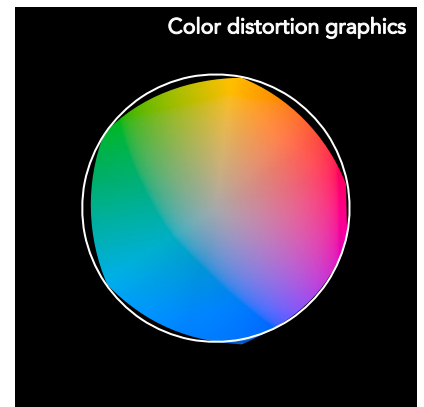
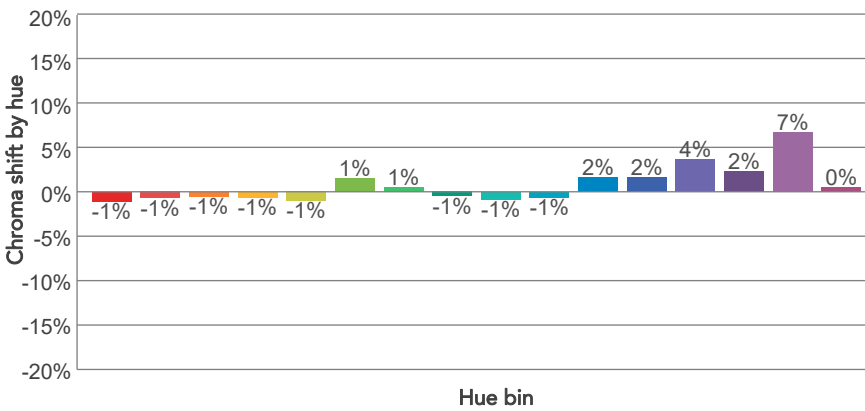
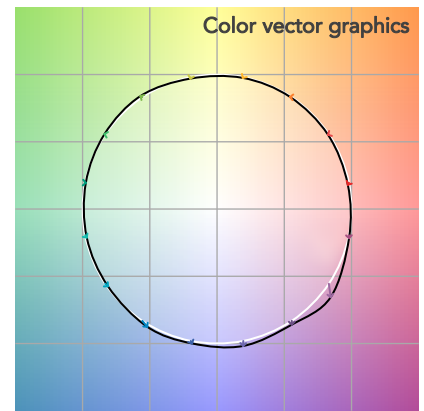
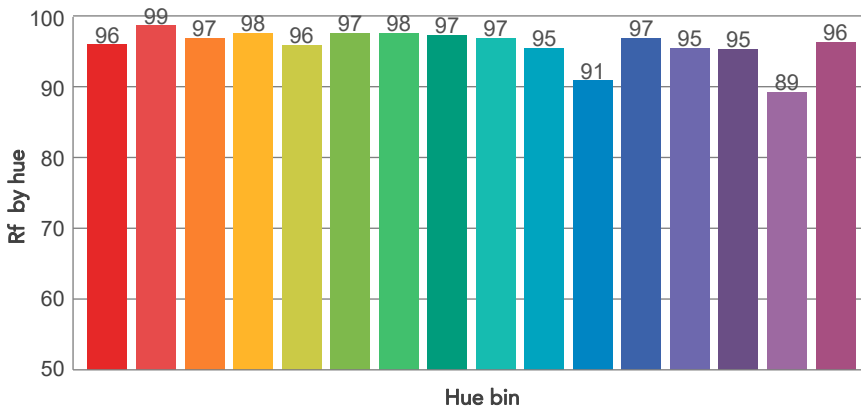
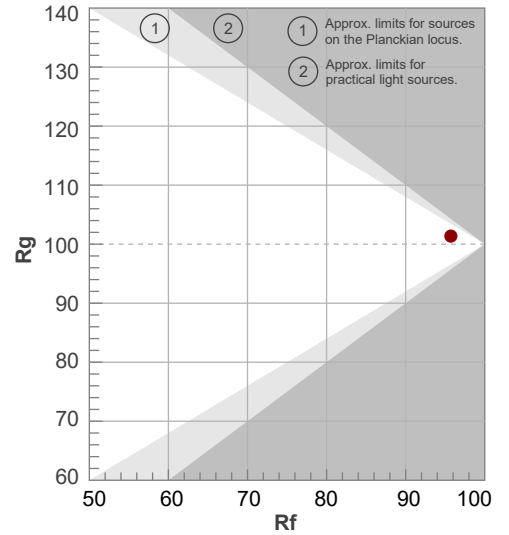

BEAM DETAILS



Beam angle 50%	Field angle 10%	Cut off angle 2,5%	Intensity ratio in 120° cone	Intensity ratio in 90° cone
35,3°	36,6°	38°	99,8%	99,8%

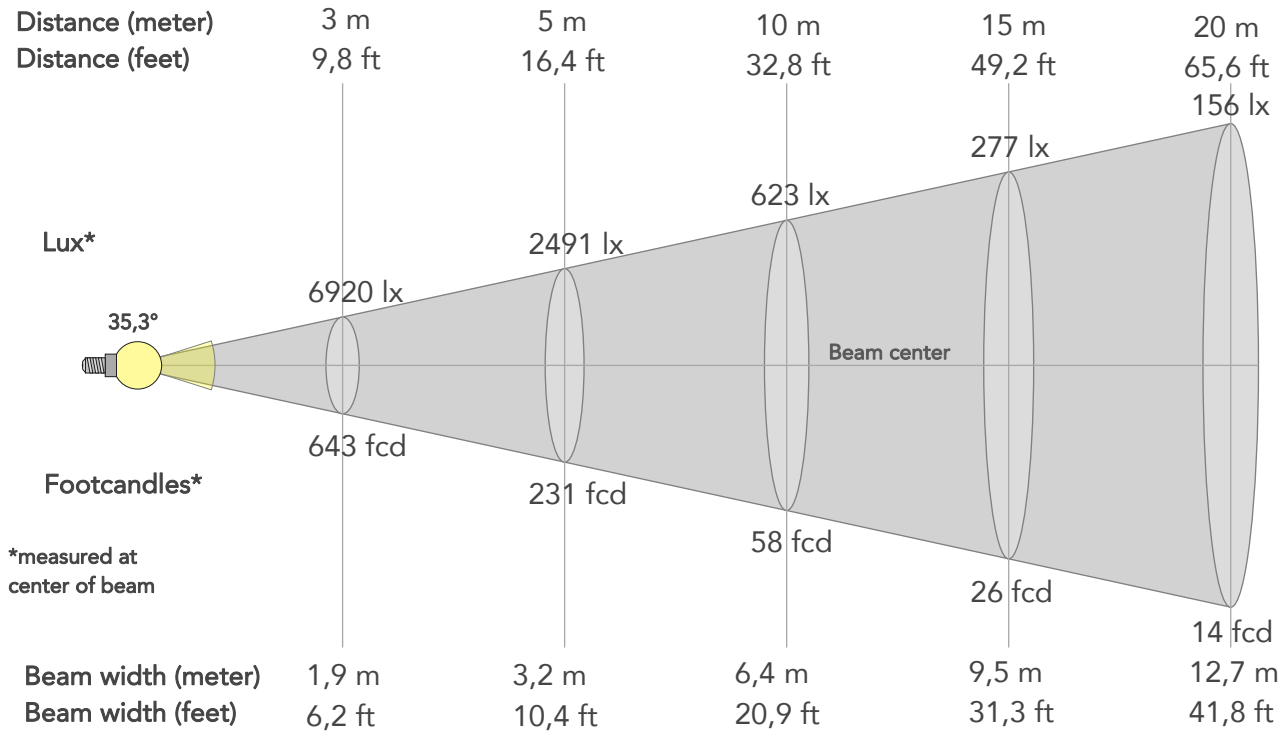

BEAM INTENSITIES AND WIDTHS

Distance	1m	2m	3m	4m	5m	7,5m	10m	15m	20m	25m	30m	40m	50m
Distance	3,3ft	6,6ft	9,8ft	13,1ft	16,4ft	24,6ft	32,8ft	49,2ft	65,6ft	82ft	98,4ft	131,2ft	164ft
Lux	62279lx	15570lx	6920lx	3892lx	2491lx	1107lx	623lx	277lx	156lx	100lx	69lx	39lx	25lx
Footcand.	5786fcd	1446fcd	643fcd	362fcd	231fcd	103fcd	58fcd	26fcd	14fcd	9fcd	6fcd	4fcd	2fcd
Beam wid.	0,6m	1,3m	1,9m	2,5m	3,2m	4,8m	6,4m	9,5m	12,7m	15,9m	19,1m	25,5m	31,8m
Beam wid.	2,1ft	4,2ft	6,2ft	8,3ft	10,4ft	15,7ft	20,9ft	31,3ft	41,8ft	52,2ft	62,6ft	83,5ft	104,4ft

LINEAR DISTRIBUTION DIAGRAM

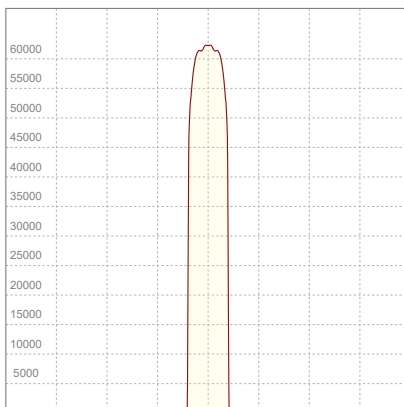

ELECTRICAL SPECIFICATIONS

Input voltage	Input current	Input power	Power FC	Efficiency
225V	1,99A	436,4W	0,97	40lm/W

ISO DIAGRAMS

ISO CANDELA DIAGRAM

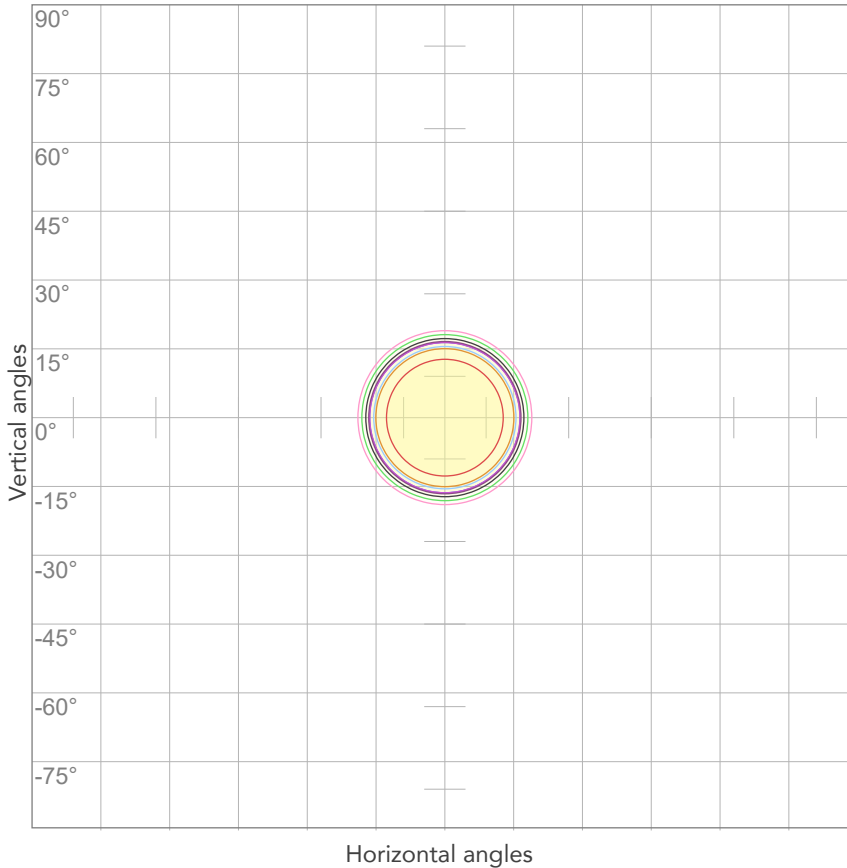

10%	6228 cd
20%	12456 cd
30%	18684 cd
40%	24911 cd
50%	31139 cd
60%	37367 cd
70%	43595 cd
80%	49823 cd

Conditions:

Number of c-planes: 2

Candela at center: 62279 cd

ISO LUX DIAGRAM

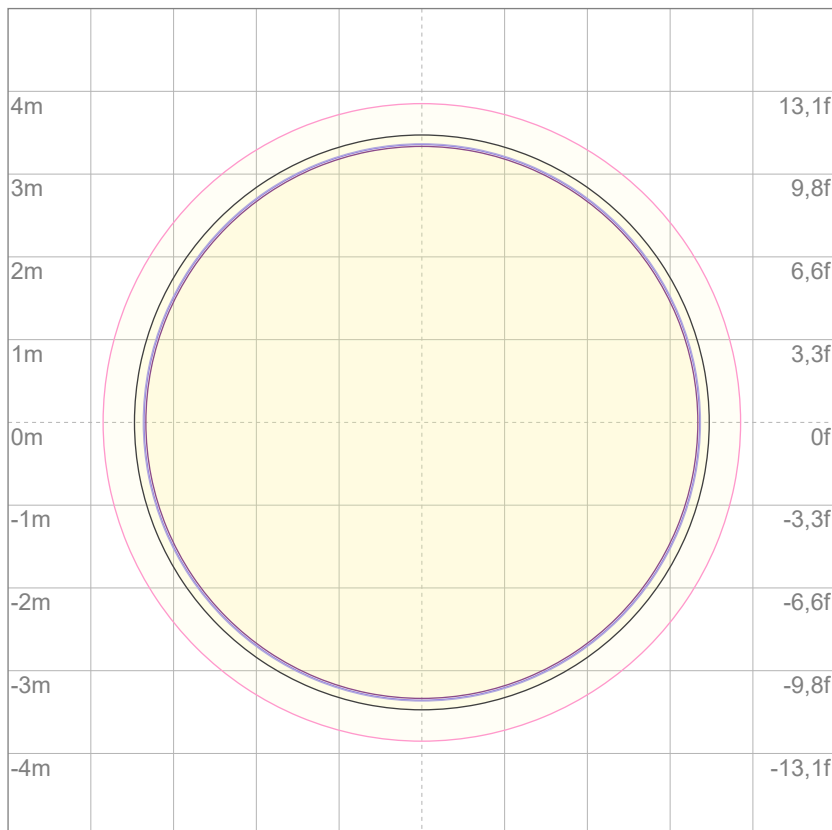

3%	18,7 lx
5%	31,1 lx
10%	62,3 lx
30%	187 lx
50%	311 lx

Conditions:

Number of c-planes: 2

Lux at center: 623 lx

Lux distribution on a surface when lamp is mounted at 10 meters from the surface.



Total lumen output:

17024 lm

Peak candela output:

61693 cd

Light quality:

CRI: 96,4

Color temperature:

5949 K

PRODUCT NAME:

ECLFWHPVW

MEASURAMENT CONDITIONS:

Beam angle:

PRL36

Target:

3200K

Operator:

Giuseppe della Peruta

Date and time:

08/01/2026 16:28:47

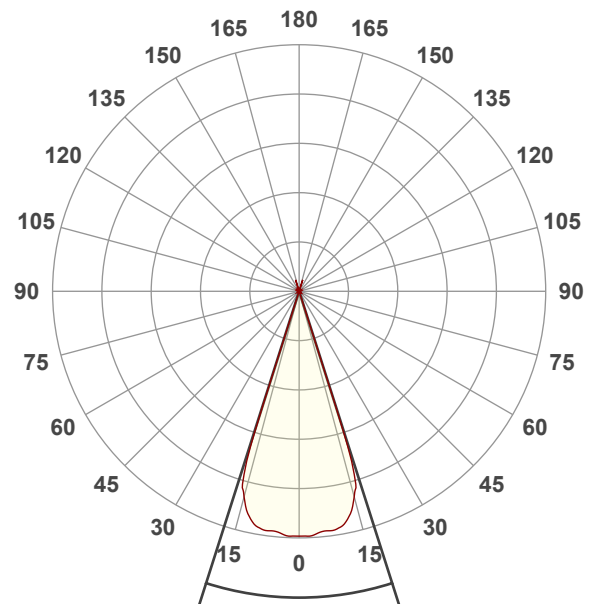

Beam angle 50%: 35,4°

Field angle 10%: 36,7°

Cut off angle 2.5%: 36,9°

Spectra

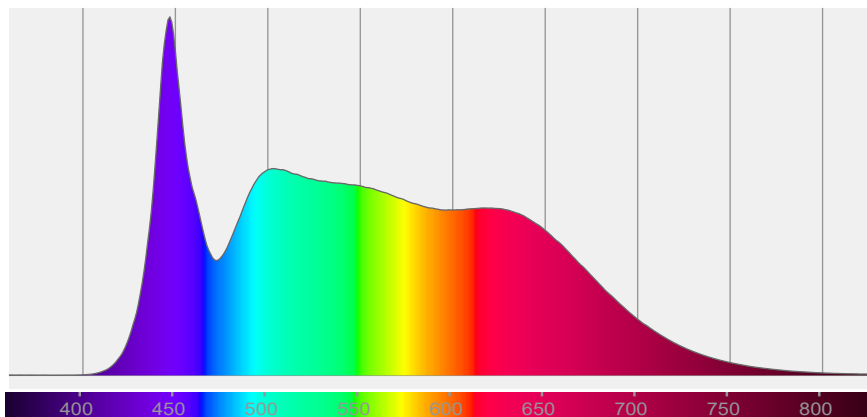

COLOR DETAILS

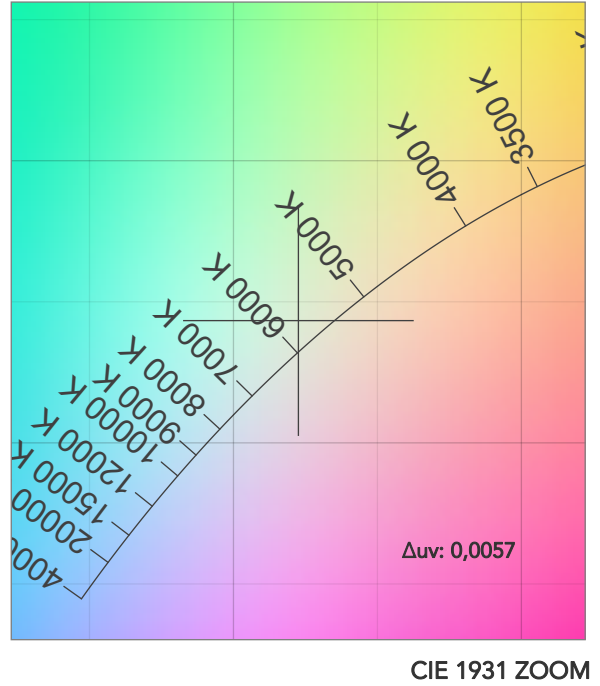
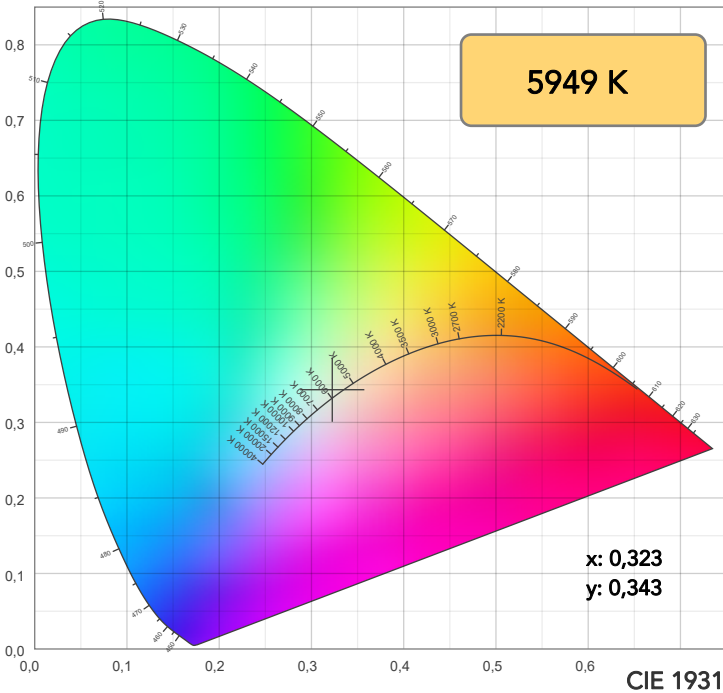

TM30: 95,3

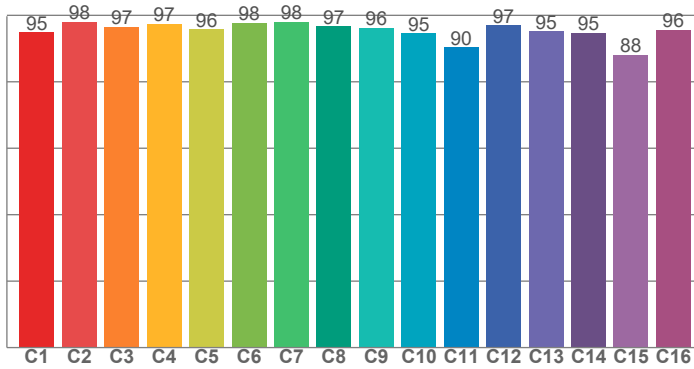

CRI: 96,4 (R1-R8)

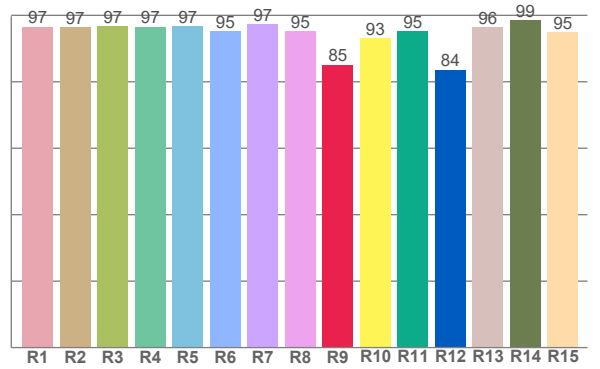

CRI R values, only R1-R8 are used to calculate final CRI value

R1	R2	R3	R4	R5	R6	R7	R8	R9	R10	R11	R12	R13	R14	R15
96,6	96,5	96,8	96,6	96,6	95,1	97,3	95,3	85,2	93,1	95,2	83,7	96,4	98,6	95,0

TM30 C values, 16 binned values out of total of 99 C values

C1	C2	C3	C4	C5	C6	C7	C8	C9	C10	C11	C12	C13	C14	C15	C16
95,0	98,0	96,5	97,5	95,8	97,8	98,0	96,7	96,3	94,6	90,4	97,0	95,1	94,7	88,1	95,7

CQS Q values

Q1	Q2	Q3	Q4	Q5	Q6	Q7	Q8	Q9	Q10	Q11	Q12	Q13	Q14	Q15
96,8	99,4	93,0	95,3	97,7	96,5	97,4	99,1	99,8	98,4	98,8	98,5	98,5	96,0	96,4

CQS: 96,9

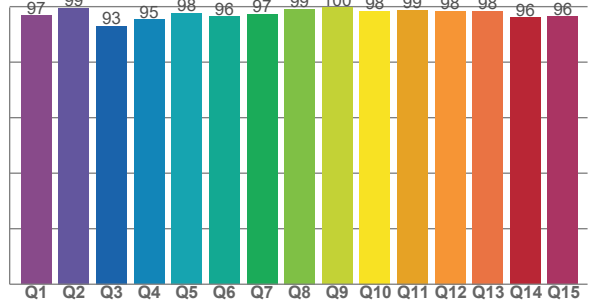

COLOR PARAMETERS

Color temperature	Color rendering index	Red component	Color fidelity	Color gamut	Color quality scale	Television lighting index	Color coordinate cie 1931	Color coordinate cie 1931	Color deviation from black body
CCT	CRI	CRI R9	TM30 Rf	TM30 Rg	CQS	TLCI	x	y	Δuv
5949 K	96,4	85,2	95,3	100,7	96,9	99	0,323	0,343	0,0057

TM30 DETAILS

Rf 95,3
Fidelity index Rf

Rg 100,7
Gammut index

Hue Bin	R _f	Graphic shifts (%)	
		Chroma	Hue
1	95	-2%	-1%
2	98	-1%	0%
3	97	-1%	1%
4	97	-1%	0%
5	96	-2%	0%
6	98	0%	0%
7	98	1%	0%
8	97	-1%	0%
9	96	-1%	2%
10	95	-1%	3%
11	90	2%	6%
12	97	2%	1%
13	95	4%	-1%
14	95	2%	-2%
15	88	7%	-9%
16	96	0%	-2%

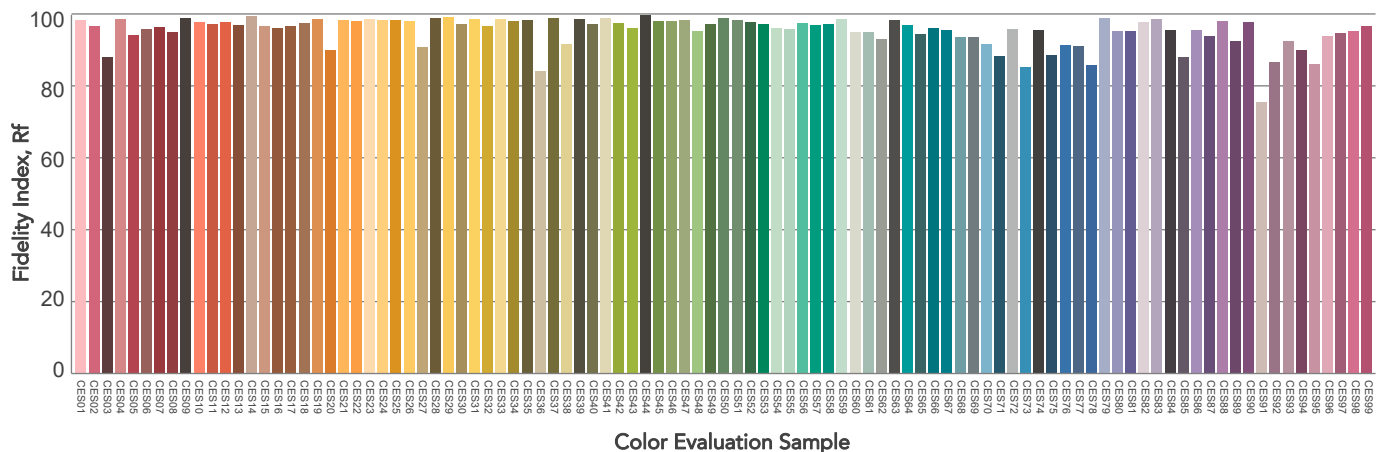
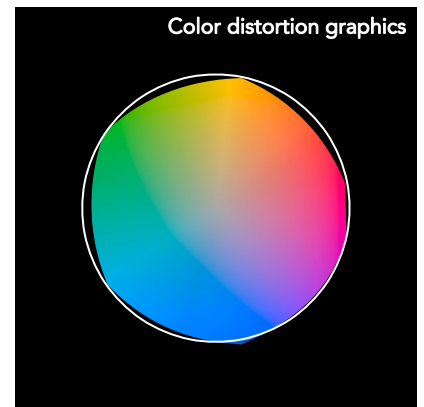
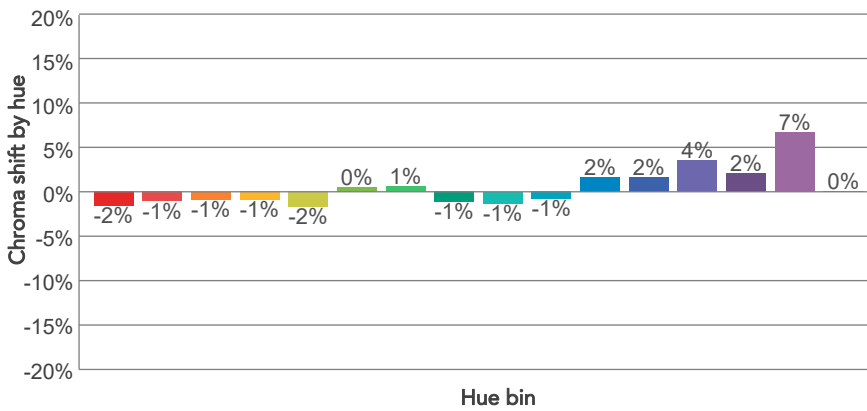
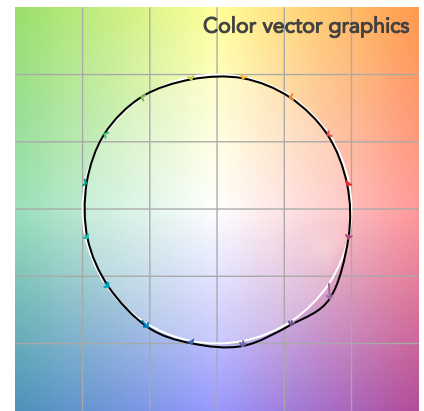
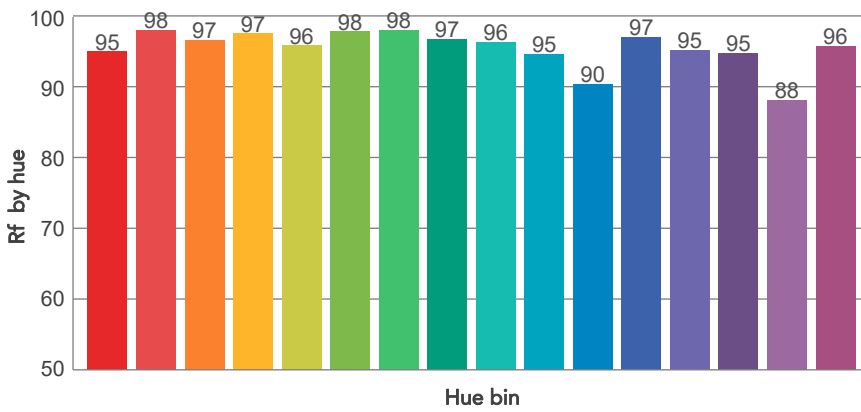
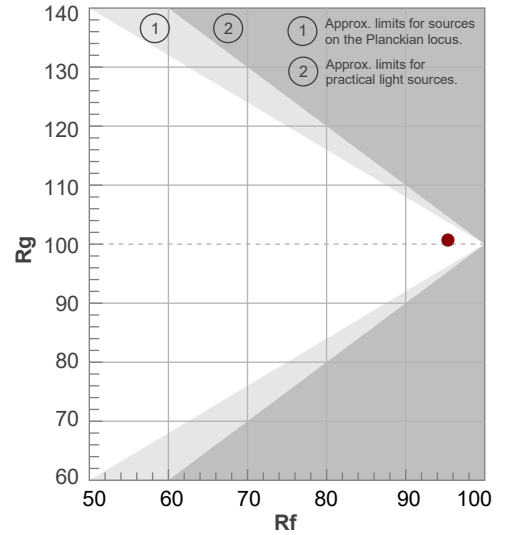

BEAM DETAILS



Beam angle 50%	Field angle 10%	Cut off angle 2,5%	Intensity ratio in 120° cone	Intensity ratio in 90° cone
35,4°	36,7°	36,9°	99,8%	99,8%

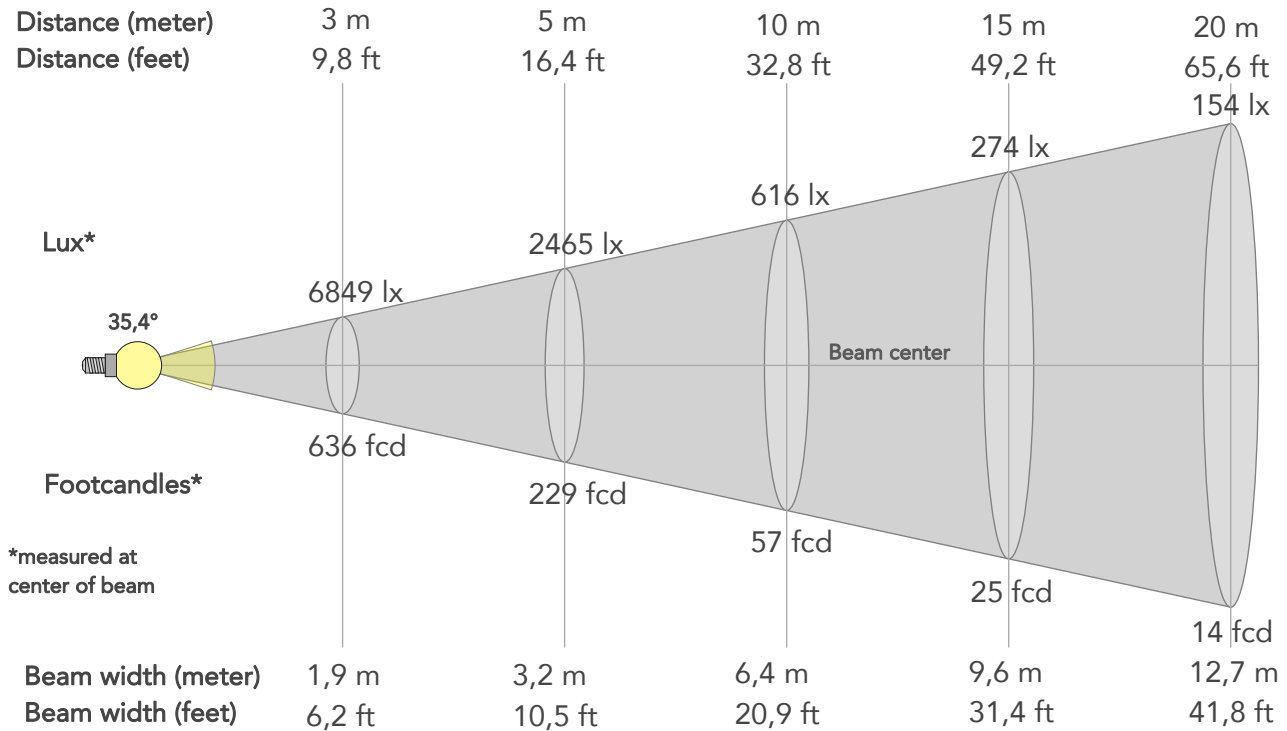

BEAM INTENSITIES AND WIDTHS

Distance	1m	2m	3m	4m	5m	7,5m	10m	15m	20m	25m	30m	40m	50m
Distance	3,3ft	6,6ft	9,8ft	13,1ft	16,4ft	24,6ft	32,8ft	49,2ft	65,6ft	82ft	98,4ft	131,2ft	164ft
Lux	61637lx	15409lx	6849lx	3852lx	2465lx	1096lx	616lx	274lx	154lx	99lx	68lx	39lx	25lx
Footcand.	5726fcd	1432fcd	636fcd	358fcd	229fcd	102fcd	57fcd	25fcd	14fcd	9fcd	6fcd	4fcd	2fcd
Beam wid.	0,6m	1,3m	1,9m	2,5m	3,2m	4,8m	6,4m	9,6m	12,7m	15,9m	19,1m	25,5m	31,9m
Beam wid.	2,1ft	4,2ft	6,2ft	8,4ft	10,5ft	15,7ft	20,9ft	31,4ft	41,8ft	52,3ft	62,7ft	83,6ft	104,5ft

LINEAR DISTRIBUTION DIAGRAM

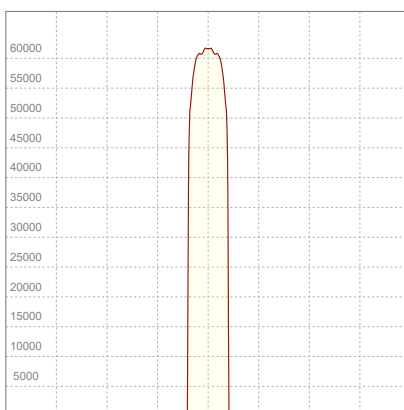

ELECTRICAL SPECIFICATIONS

Input voltage	Input current	Input power	Power FC	Efficiency
225V	1,96A	426,2W	0,97	40lm/W

ISO DIAGRAMS

ISO CANDELA DIAGRAM

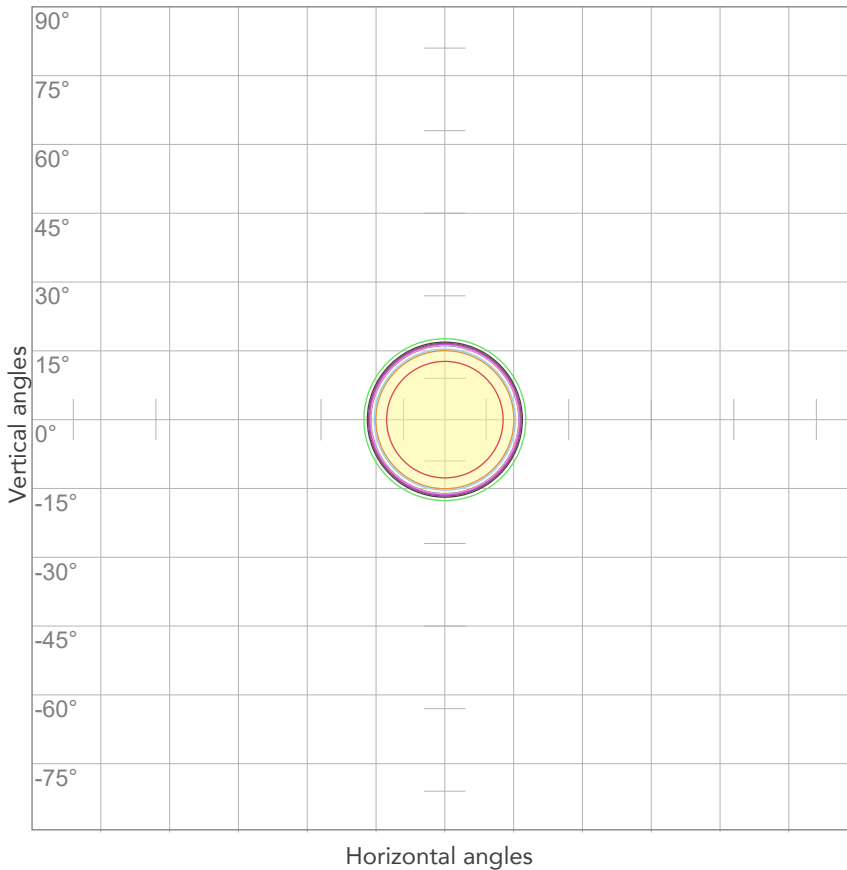

10%	6164 cd
20%	12327 cd
30%	18491 cd
40%	24655 cd
50%	30818 cd
60%	36982 cd
70%	43146 cd
80%	49309 cd

Conditions:

Number of c-planes: 2

Candela at center: 61637 cd

ISO LUX DIAGRAM

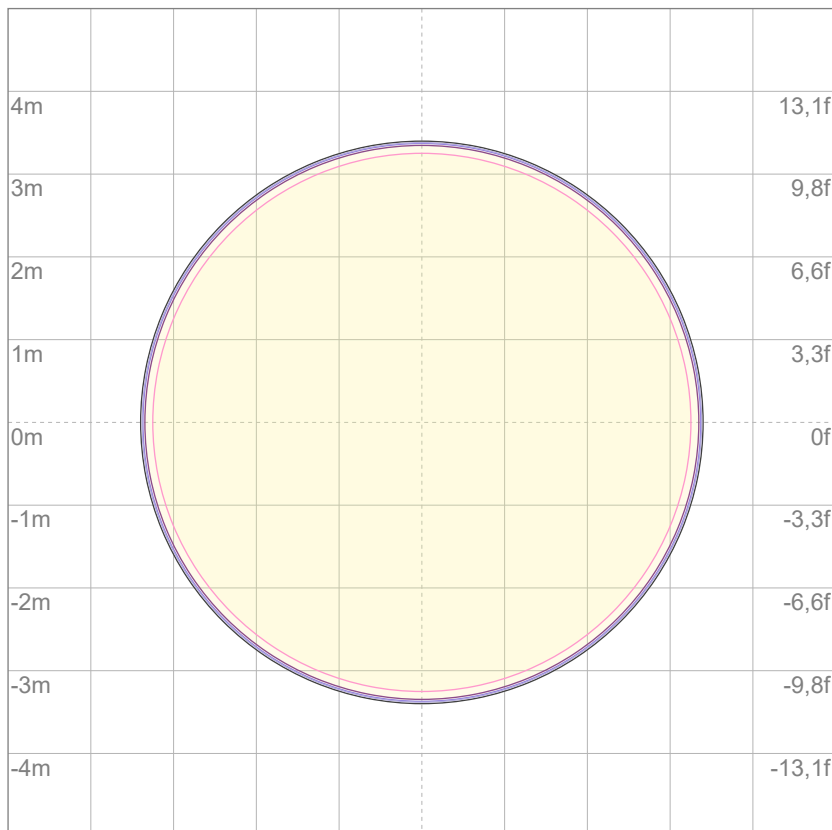

Mounting height: 10 meters (33 feet)

3%	18,5 lx
5%	30,8 lx
10%	61,6 lx
30%	185 lx
50%	308 lx

Conditions:

Number of c-planes: 2

Lux at center: 616 lx

Lux distribution on a surface when lamp is mounted at 10 meters from the surface.