

Photometric Test Report



EclProfile FWHPVW

450W high quality VariableWhite LED
ellipsoidal, compatible with PRL and PRLZ lenses

(ECLPRL70BK)

CONTENTS

Table of contents	2
Testing process	3
PRL 70° Lens:	
Full On	4
Warm White	9
Cold White	14
2800K	19
3200K	24
4000K	29
5600K	34
6000K	39

TESTING PROCESS

Prolights has its own optical testing laboratory in order to provide accurate photometric reports for its lighting products. The testing laboratory contains certain variety of precise lighting measurement systems that ensure an optimal reading of all the characteristic parameters of the lighting devices. All measurements are made at a controlled room temperature of 20°C without any external light sources. This photometric report is obtained through the data measured by a high precision measurement system and analyzed by a dedicate software.

Prolights measurement instrument

Prolights measurement instrument is a complete measurement system for any light source. It's equipped with two-axis goniometer, that enables to measure the full 3D distribution field of the light source. This instrument measures the light intensity, the beam angle and the most significative colors parameters, like color temperature, spectral distribution, CRI, CQS, TM-30 with a very high accuracy rate.

Please Note: All measurements are made with light source at operating temperature. Before starting the measurement, the instrument analyzes the process of the light source during the heating phase. The measuring process of all the parameters begins only when the light emission is stable, that is with a variation of less than 0.5% in a 15 minutes time frame.

Prolights measurement software

The software provides user friendly interface for the operator who does the measurements, and it also analyzes and processes all the collected data by the instrument. With this software it is possible to see the measured data in real-time and it is possible to examine all the measured data and graphics afterwards as well. All information is collected in a specific Prolights template, and the software creates also IES and LDT files, which are widely used to transfer the photometric data, and to develop lighting system.

Additionally, the fixtures are rechecked using various hand-held instruments like Sekonic C-700 and Gossen Mavospec Base, this is done to ensure, that the data in the photometric report are as accurate as possible.



Total lumen output:

18155 lm

Peak candela output:

20052 cd

Light quality:

CRI: 98,1

Color temperature:

4202 K

PRODUCT NAME:

ECLFWHPVW

MEASUREMENT CONDITIONS:

Beam angle:

PRL70

Target:

Full On

Operator:

Giuseppe della Peruta

Date and time:

08/01/2026 17:26:49

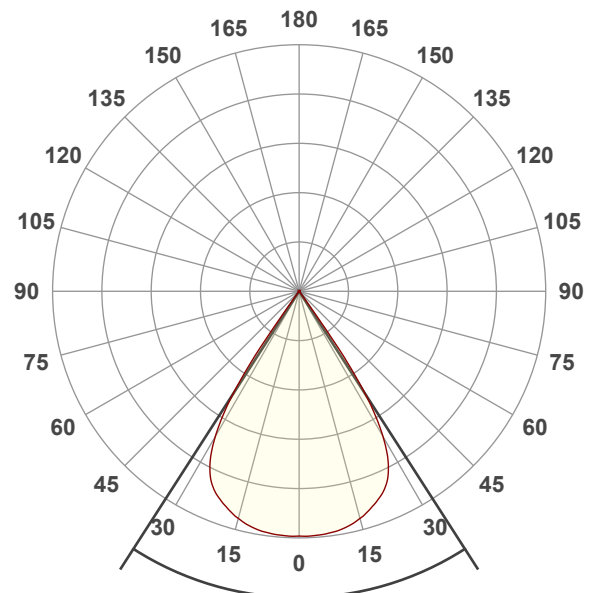

Beam angle 50%: 65,5°

Field angle 10%: 71,2°

Cut off angle 2.5%: 72,7°

Spectra

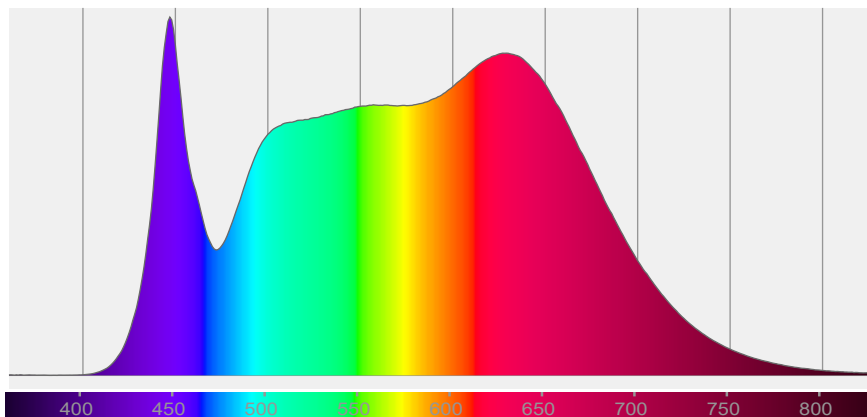

COLOR DETAILS

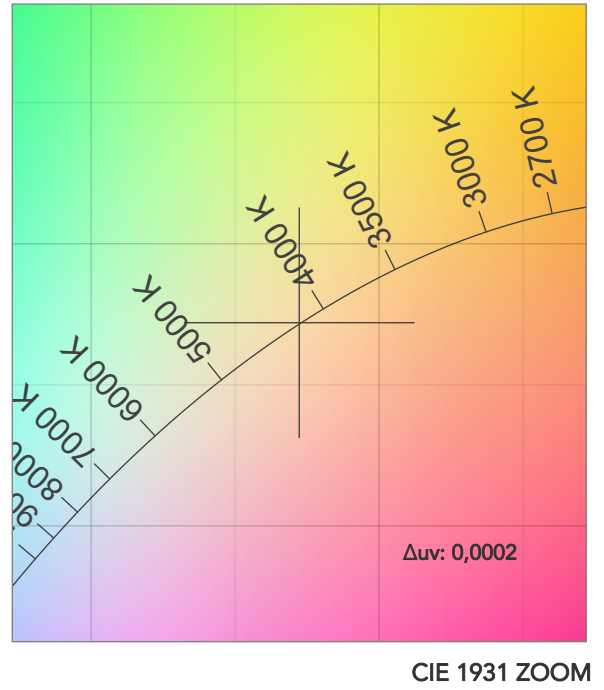
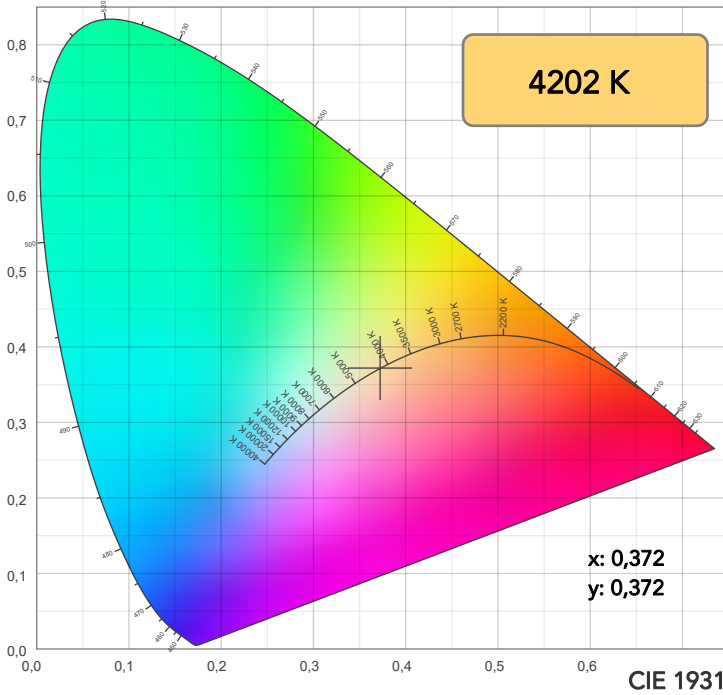

TM30: 96,0

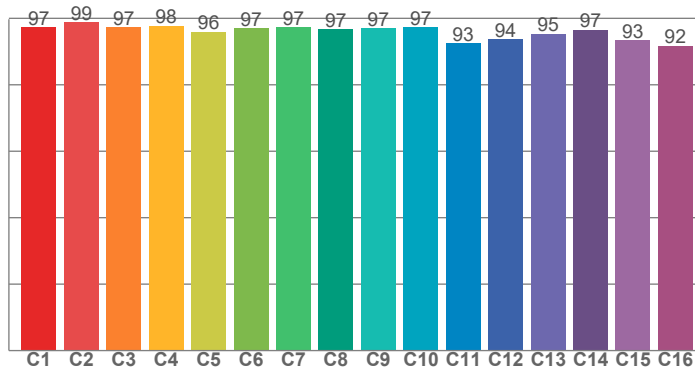

CRI: 98,1 (R1-R8)

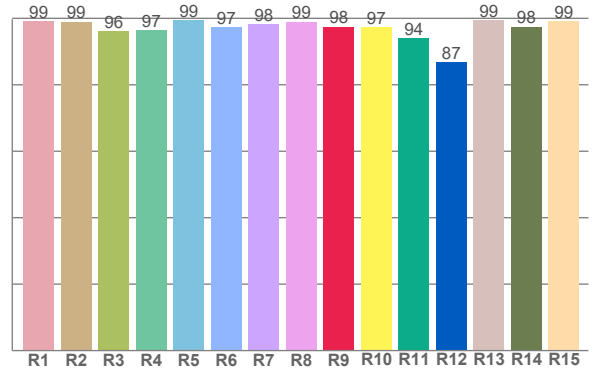

CRI R values, only R1-R8 are used to calculate final CRI value

R1	R2	R3	R4	R5	R6	R7	R8	R9	R10	R11	R12	R13	R14	R15
99,1	99,0	96,2	96,5	99,5	97,4	98,3	99,0	97,5	97,3	94,1	86,8	99,4	97,5	99,1

TM30 C values, 16 binned values out of total of 99 C values

C1	C2	C3	C4	C5	C6	C7	C8	C9	C10	C11	C12	C13	C14	C15	C16
97,3	98,8	97,4	97,7	95,9	97,0	97,3	96,7	97,0	97,4	92,5	93,8	95,3	96,6	93,4	91,8

CQS Q values

Q1	Q2	Q3	Q4	Q5	Q6	Q7	Q8	Q9	Q10	Q11	Q12	Q13	Q14	Q15
98,3	99,7	93,8	96,7	98,5	96,4	98,0	99,5	98,9	98,9	99,6	98,9	99,0	99,3	99,0

CQS: 97,7

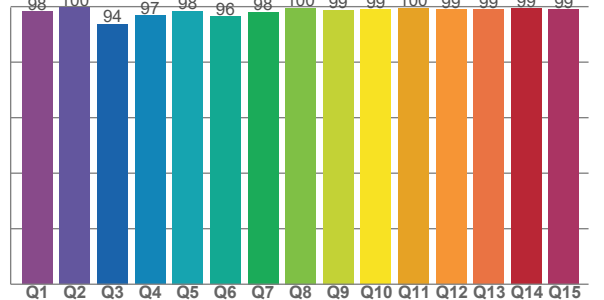

COLOR PARAMETERS

Color temperature	Color rendering index	Red component	Color fidelity	Color gamut	Color quality scale	Television lighting index	Color coordinate cie 1931	Color coordinate cie 1931	Color deviation from black body
CCT	CRI	CRI R9	TM30 Rf	TM30 Rg	CQS	TLCI	x	y	Δuv
4202 K	98,1	97,5	96,0	102,0	97,7	98	0,372	0,372	0,0002

TM30 DETAILS

Rf 96,0
Fidelity index Rf

Rg 102,0
Gammut index

Hue Bin	R _f	Graphic shifts (%)	
		Chroma	Hue
1	97	0%	-1%
2	99	0%	0%
3	97	0%	1%
4	98	-1%	0%
5	96	-1%	1%
6	97	2%	1%
7	97	1%	0%
8	97	1%	0%
9	97	0%	1%
10	97	-1%	1%
11	93	2%	5%
12	94	3%	2%
13	95	4%	-1%
14	97	2%	0%
15	93	3%	-4%
16	92	2%	-5%

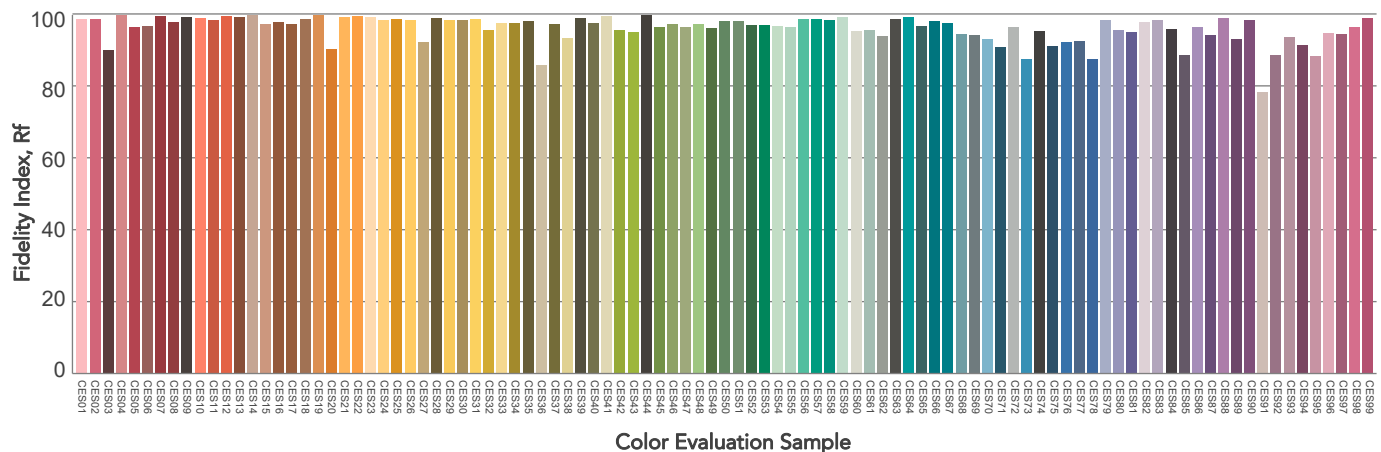
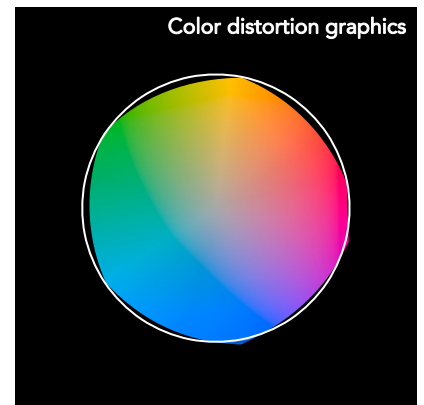
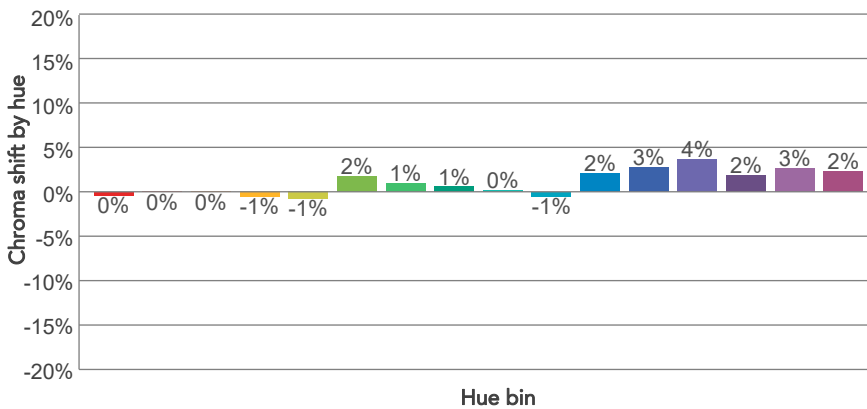
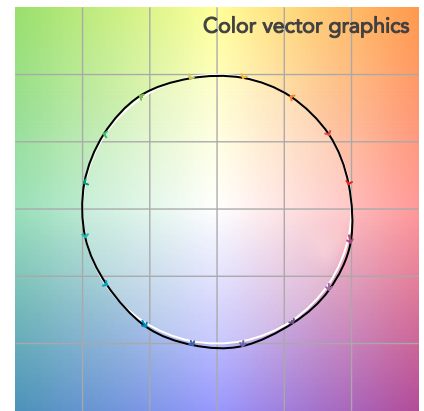
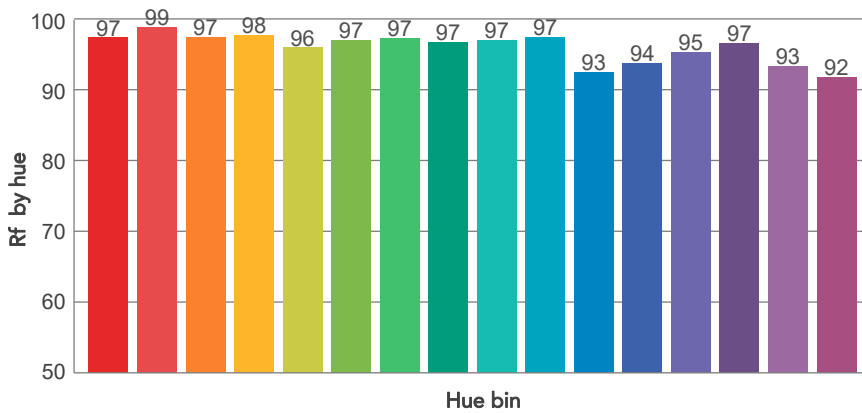
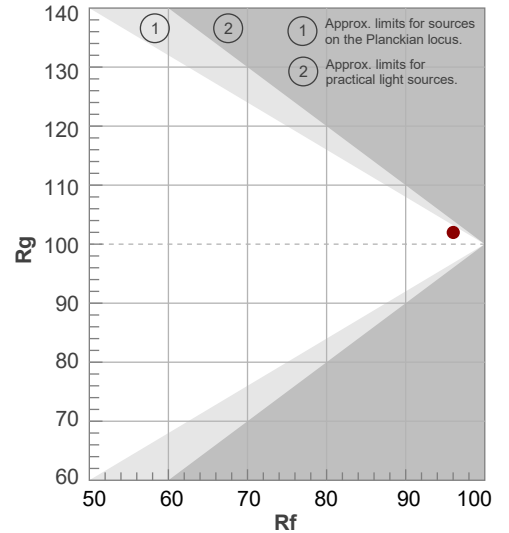

BEAM DETAILS



Beam angle 50%	Field angle 10%	Cut off angle 2,5%	Intensity ratio in 120° cone	Intensity ratio in 90° cone
65,5°	71,2°	72,7°	99,8%	99,7%

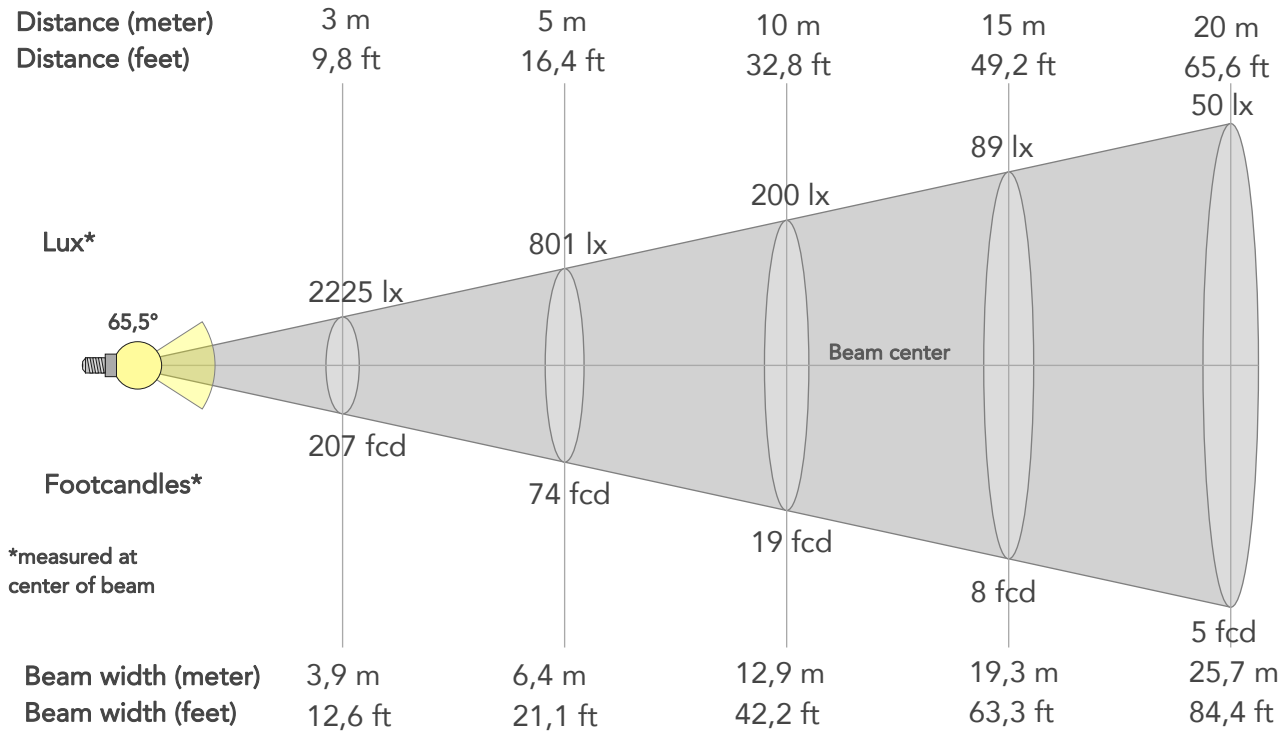

BEAM INTENSITIES AND WIDTHS

Distance	1m	2m	3m	4m	5m	7,5m	10m	15m	20m	25m	30m	40m	50m
Distance	3,3ft	6,6ft	9,8ft	13,1ft	16,4ft	24,6ft	32,8ft	49,2ft	65,6ft	82ft	98,4ft	131,2ft	164ft
Lux	20027lx	5007lx	2225lx	1252lx	801lx	356lx	200lx	89lx	50lx	32lx	22lx	13lx	8lx
Footcand.	1861fcd	465fcd	207fcd	116fcd	74fcd	33fcd	19fcd	8fcd	5fcd	3fcd	2fcd	1fcd	1fcd
Beam wid.	1,3m	2,6m	3,9m	5,1m	6,4m	9,7m	12,9m	19,3m	25,7m	32,2m	38,6m	51,5m	64,3m
Beam wid.	4,2ft	8,5ft	12,6ft	16,9ft	21,1ft	31,7ft	42,2ft	63,3ft	84,4ft	105,5ft	126,6ft	168,8ft	211ft

LINEAR DISTRIBUTION DIAGRAM

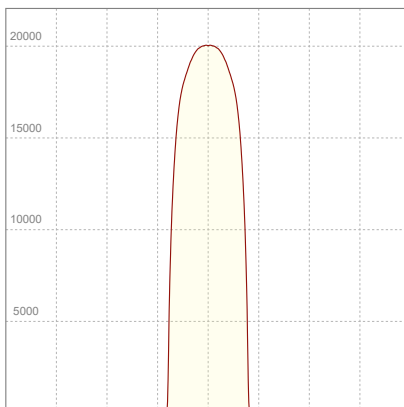

ELECTRICAL SPECIFICATIONS

Input voltage	Input current	Input power	Power FC	Efficiency
226V	2,00A	439,3W	0,97	41lm/W

ISO DIAGRAMS

ISO CANDELA DIAGRAM

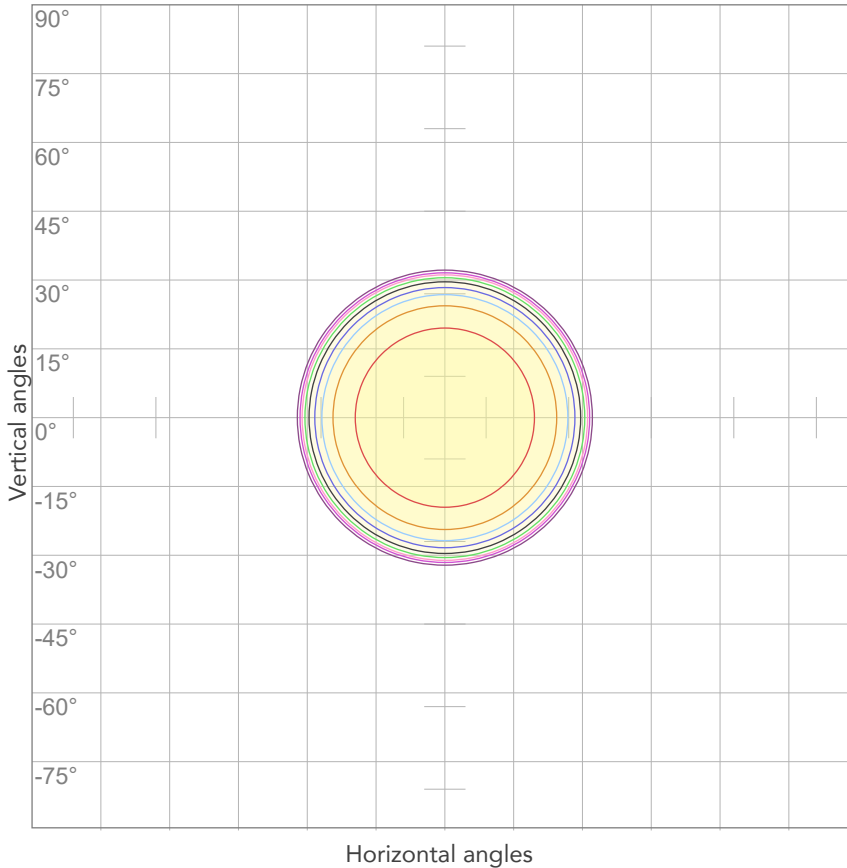

10%	2003 cd
20%	4005 cd
30%	6008 cd
40%	8011 cd
50%	10014 cd
60%	12016 cd
70%	14019 cd
80%	16022 cd

Conditions:

Number of c-planes: 2

Candela at center: 20027 cd

ISO LUX DIAGRAM

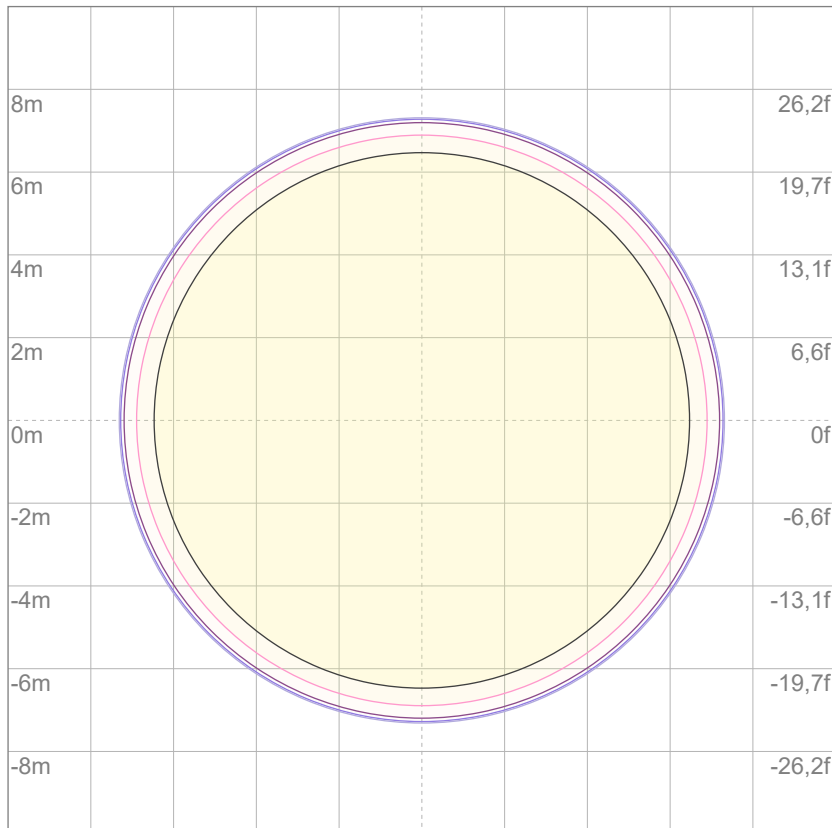

3%	6,01 lx
5%	10,0 lx
10%	20,0 lx
30%	60,1 lx
50%	100 lx

Conditions:

Number of c-planes: 2

Lux at center: 200 lx

Lux distribution on a surface when lamp is mounted at 10 meters from the surface.

Mounting height: 10 meters (33 feet)



Total lumen output:

13937 lm

Peak candela output:

15388 cd

Light quality:

CRI: 96,2

Color temperature:

2645 K

PRODUCT NAME:

ECLFWHPVW

MEASURAMENT CONDITIONS:

Beam angle:

PRL70

Target:

Warm White

Operator:

Giuseppe della Peruta

Date and time:

08/01/2026 17:30:06

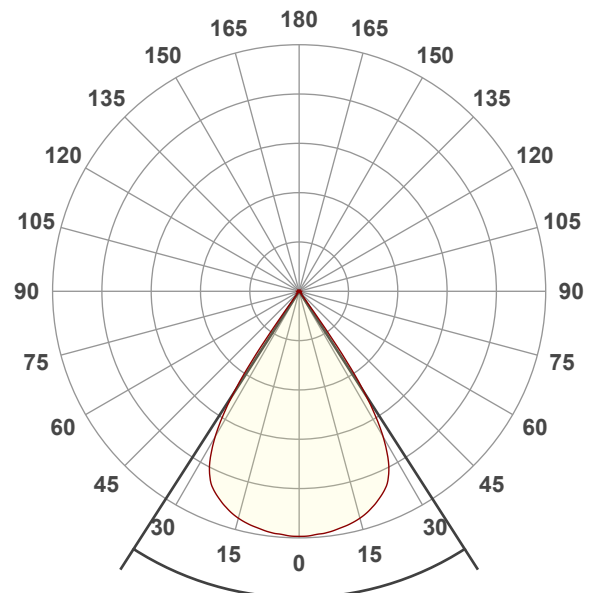

Beam angle 50%: 65,4°

Field angle 10%: 71,3°

Cut off angle 2.5%: 72,8°

Spectra

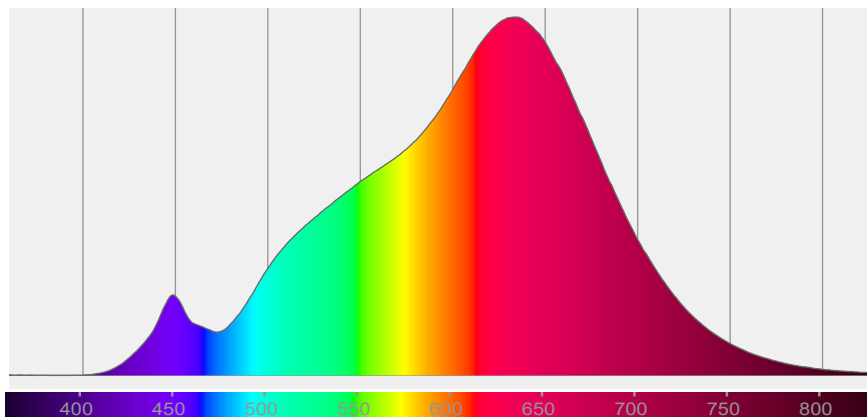

COLOR DETAILS

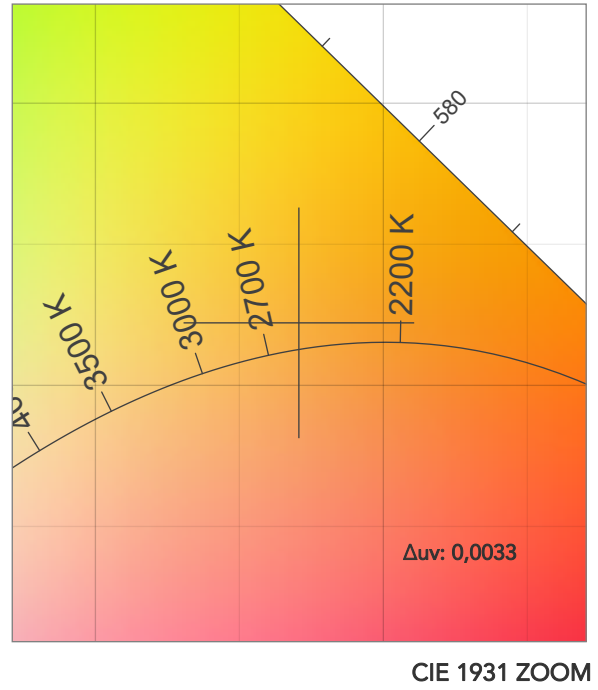
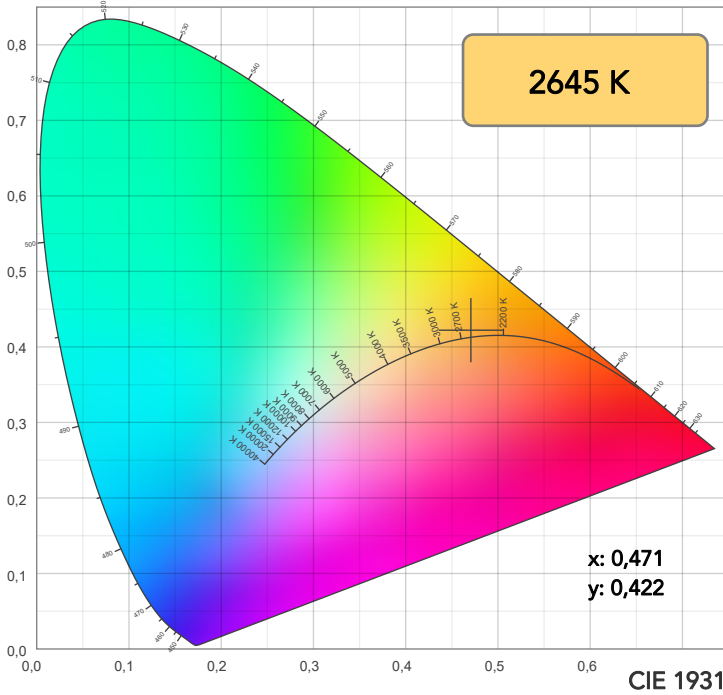

TM30: 95,9

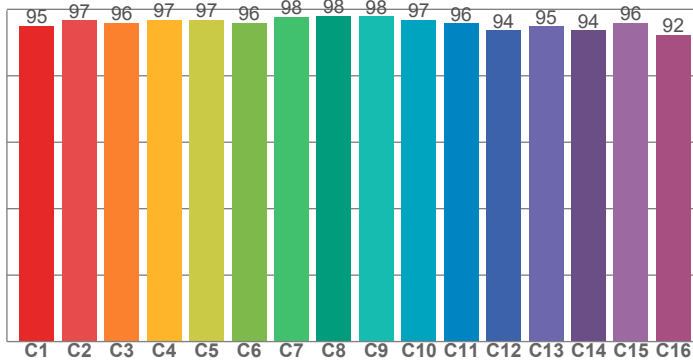

CRI: 96,2 (R1-R8)

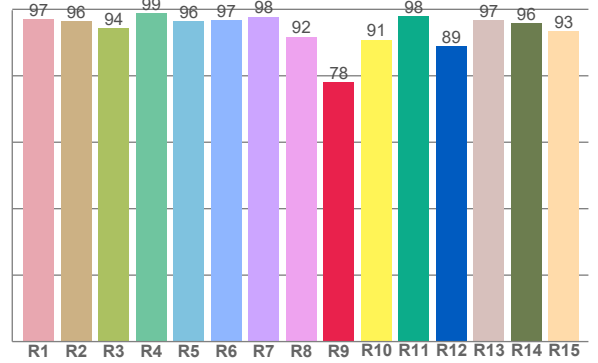

CQS: 91,7

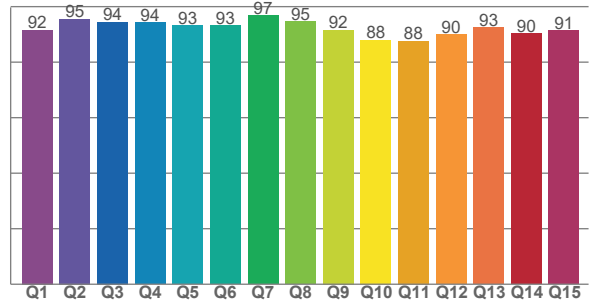

CRI R values, only R1-R8 are used to calculate final CRI value

R1	R2	R3	R4	R5	R6	R7	R8	R9	R10	R11	R12	R13	R14	R15
97,1	96,5	94,4	98,9	96,5	96,8	97,8	91,7	78,1	90,9	97,9	88,8	96,8	95,9	93,4

TM30 C values, 16 binned values out of total of 99 C values

C1	C2	C3	C4	C5	C6	C7	C8	C9	C10	C11	C12	C13	C14	C15	C16
95,1	96,6	96,0	96,8	96,8	95,9	97,7	98,0	98,0	96,8	95,9	93,7	94,9	93,8	95,9	92,4

CQS Q values

Q1	Q2	Q3	Q4	Q5	Q6	Q7	Q8	Q9	Q10	Q11	Q12	Q13	Q14	Q15
91,6	95,5	94,5	94,3	93,3	93,3	96,8	94,6	91,7	88,0	87,6	89,9	92,5	90,4	91,4

COLOR PARAMETERS

Color temperature	Color rendering index	Red component	Color fidelity	Color gamut	Color quality scale	Television lighting index	Color coordinate cie 1931	Color coordinate cie 1931	Color deviation from black body
CCT	CRI	CRI R9	TM30 Rf	TM30 Rg	CQS	TLCI	x	y	Δuv
2645 K	96,2	78,1	95,9	99,3	91,7	96	0,471	0,422	0,0033

TM30 DETAILS

Rf 95,9
Fidelity index Rf

Rg 99,3
Gammut index

Hue Bin	R _f	Graphic shifts (%)	
		Chroma	Hue
1	95	-2%	-1%
2	97	-2%	0%
3	96	-2%	1%
4	97	-1%	1%
5	97	-1%	3%
6	96	1%	3%
7	98	0%	0%
8	98	1%	0%
9	98	-1%	-1%
10	97	-1%	1%
11	96	-1%	3%
12	94	2%	-1%
13	95	1%	-4%
14	94	2%	-4%
15	96	0%	-2%
16	92	-1%	-5%

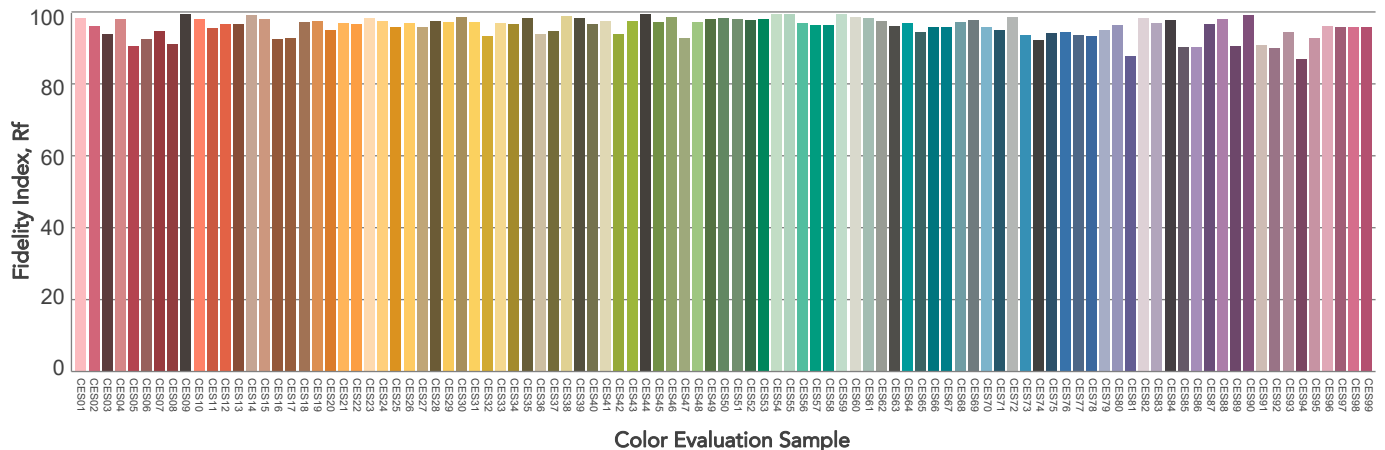
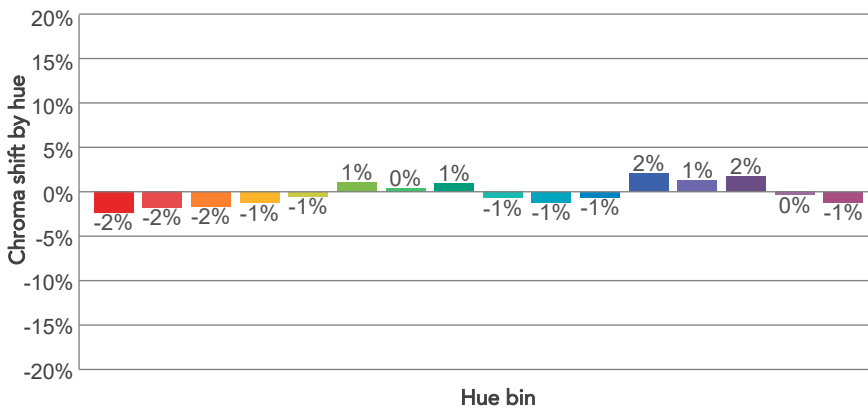
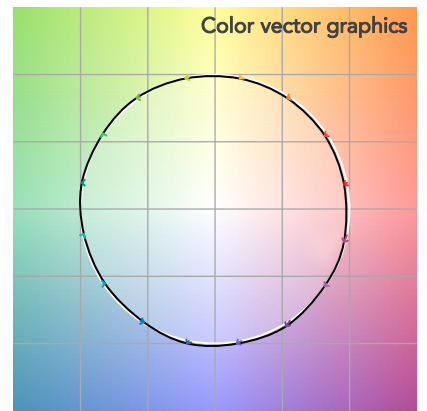
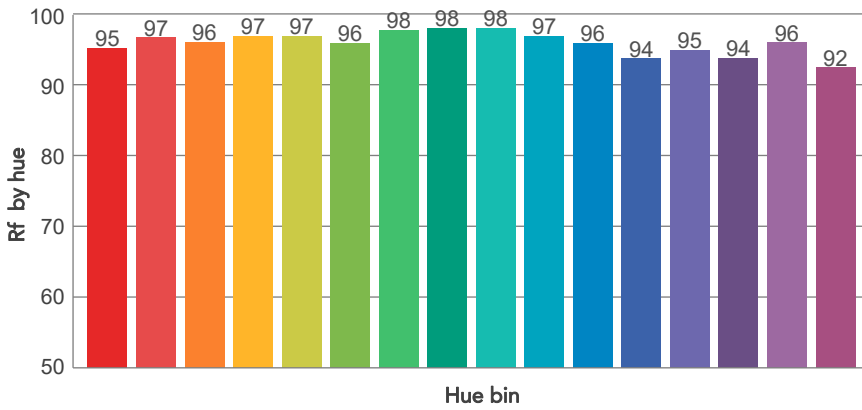
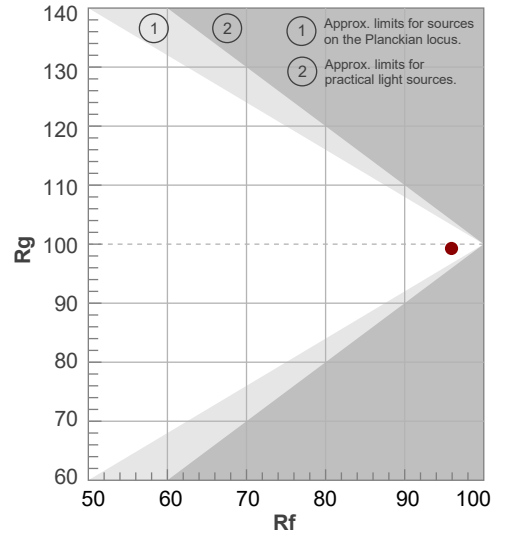

BEAM DETAILS



Beam angle 50%	Field angle 10%	Cut off angle 2,5%	Intensity ratio in 120° cone	Intensity ratio in 90° cone
65,4°	71,3°	72,8°	99,7%	99,7%

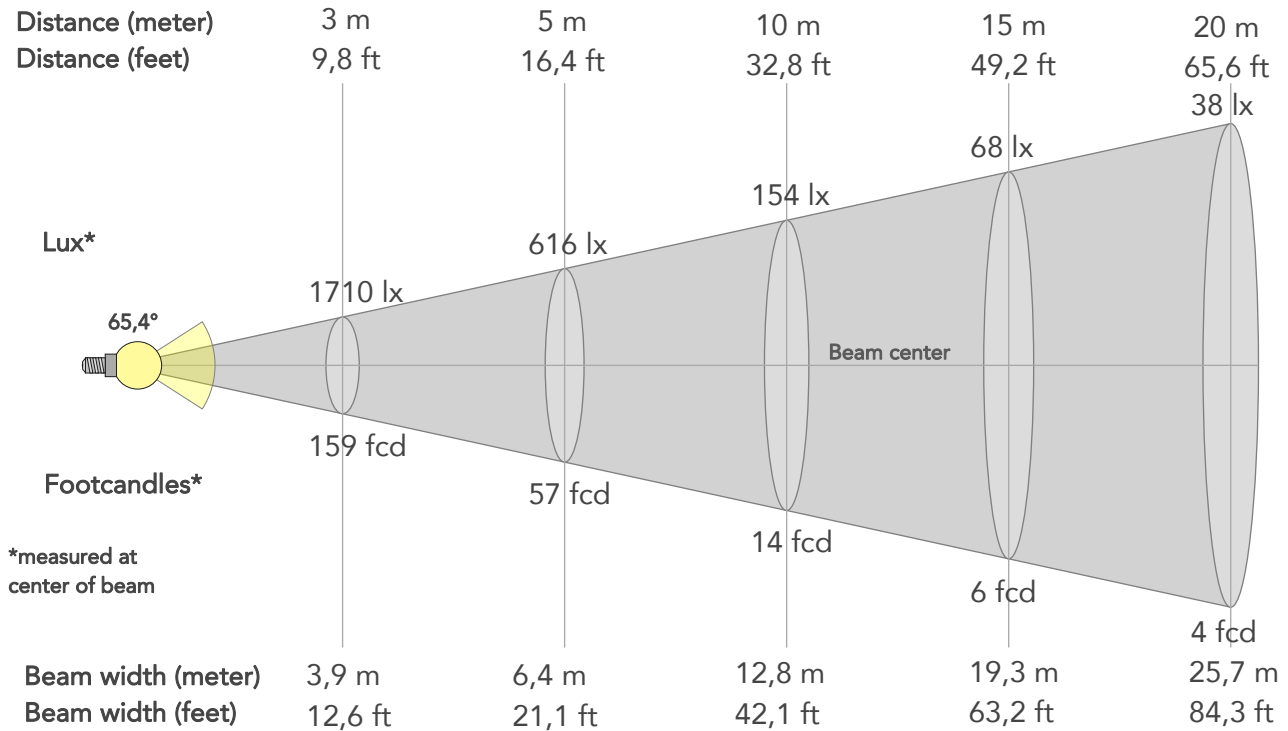

BEAM INTENSITIES AND WIDTHS

Distance	1m	2m	3m	4m	5m	7,5m	10m	15m	20m	25m	30m	40m	50m
Distance	3,3ft	6,6ft	9,8ft	13,1ft	16,4ft	24,6ft	32,8ft	49,2ft	65,6ft	82ft	98,4ft	131,2ft	164ft
Lux	15388lx	3847lx	1710lx	962lx	616lx	274lx	154lx	68lx	38lx	25lx	17lx	10lx	6lx
Footcand.	1430fcd	357fcd	159fcd	89fcd	57fcd	25fcd	14fcd	6fcd	4fcd	2fcd	2fcd	1fcd	1fcd
Beam wid.	1,3m	2,6m	3,9m	5,1m	6,4m	9,6m	12,8m	19,3m	25,7m	32,1m	38,5m	51,4m	64,2m
Beam wid.	4,2ft	8,5ft	12,6ft	16,8ft	21,1ft	31,6ft	42,1ft	63,2ft	84,3ft	105,4ft	126,4ft	168,6ft	210,7ft

LINEAR DISTRIBUTION DIAGRAM

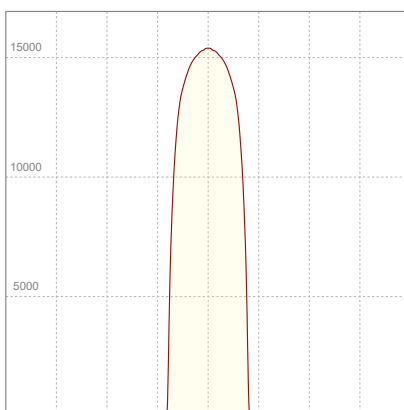

ELECTRICAL SPECIFICATIONS

Input voltage	Input current	Input power	Power FC	Efficiency
227V	1,73A	379,2W	0,97	37lm/W

ISO DIAGRAMS

ISO CANDELA DIAGRAM

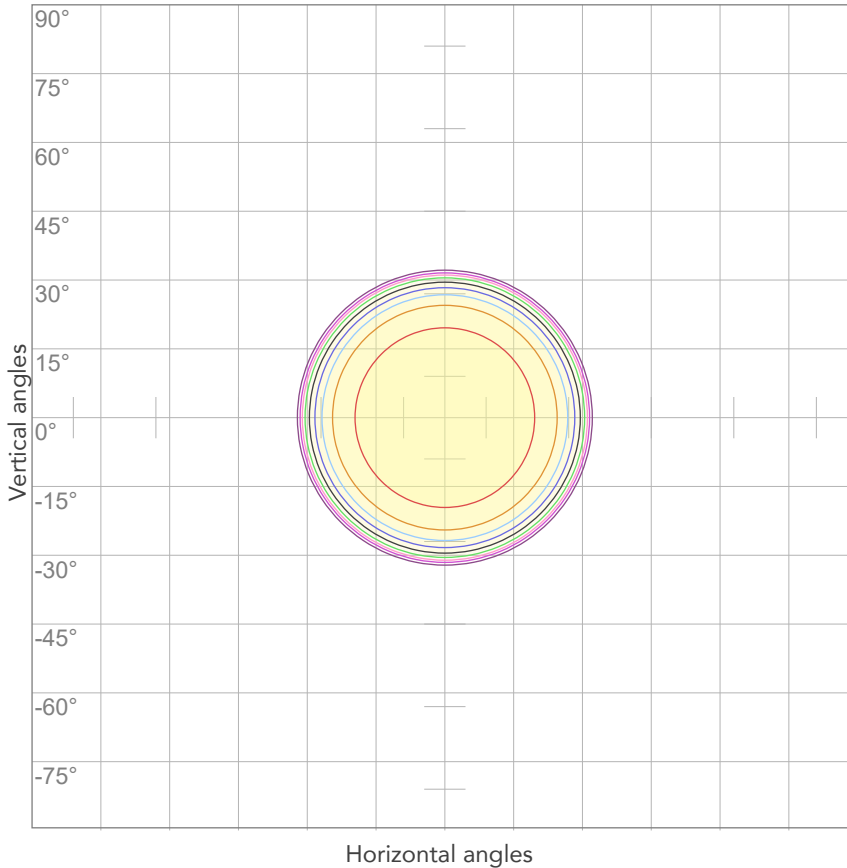

10%	1539 cd
20%	3078 cd
30%	4617 cd
40%	6155 cd
50%	7694 cd
60%	9233 cd
70%	10772 cd
80%	12311 cd

Conditions:

Number of c-planes: 2

Candela at center: 15388 cd

ISO LUX DIAGRAM

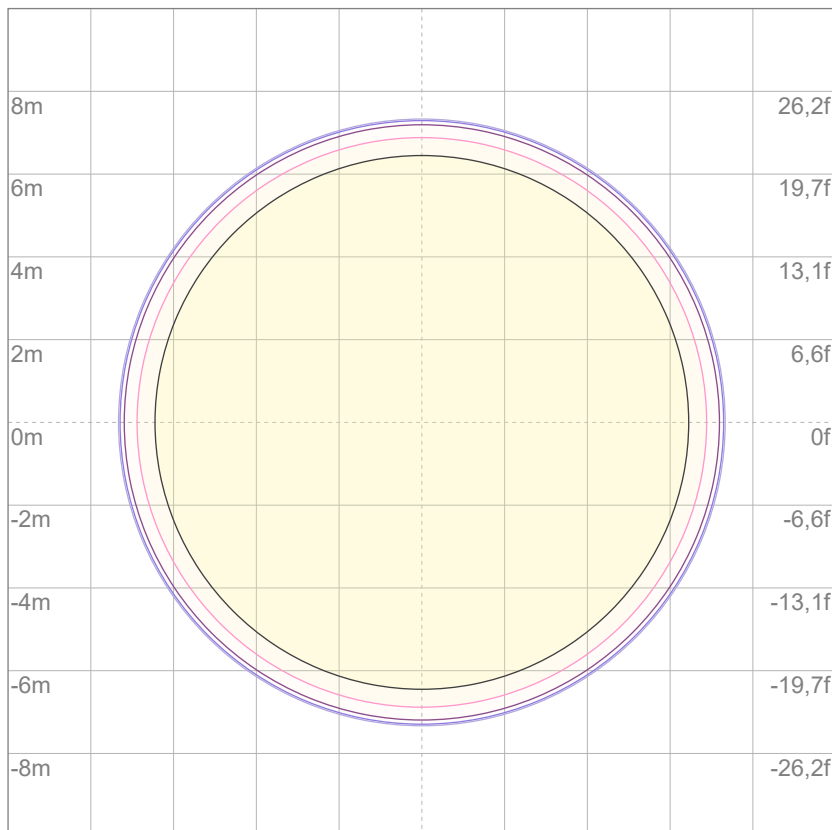

3%	4,62 lx
5%	7,69 lx
10%	15,4 lx
30%	46,2 lx
50%	76,9 lx

Conditions:

Number of c-planes: 2

Lux at center: 154 lx

Lux distribution on a surface when lamp is mounted at 10 meters from the surface.

Mounting height: 10 meters (33 feet)



Total lumen output:

17650 lm

Peak candela output:

19582 cd

Light quality:

CRI: 93,6

Color temperature:

6611 K

PRODUCT NAME:

ECLFWHPVW

MEASURAMENT CONDITIONS:

Beam angle:

PRL70

Target:

Cold White

Operator:

Giuseppe della Peruta

Date and time:

08/01/2026 17:33:13

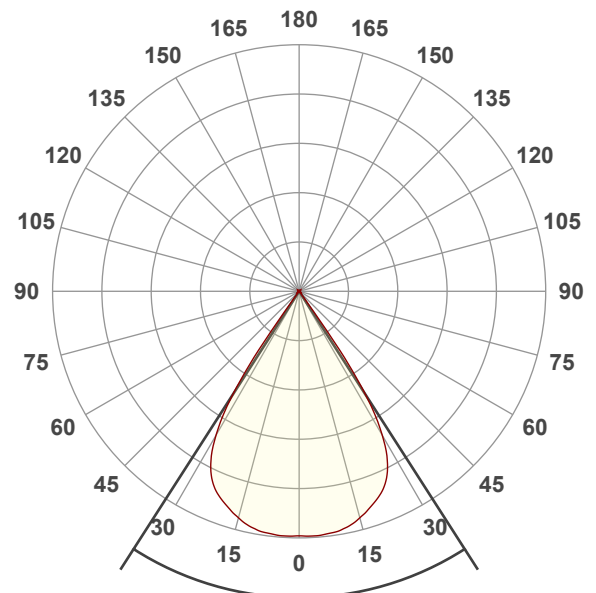

Beam angle 50%: 65,4°

Field angle 10%: 71,2°

Cut off angle 2.5%: 72,7°

Spectra

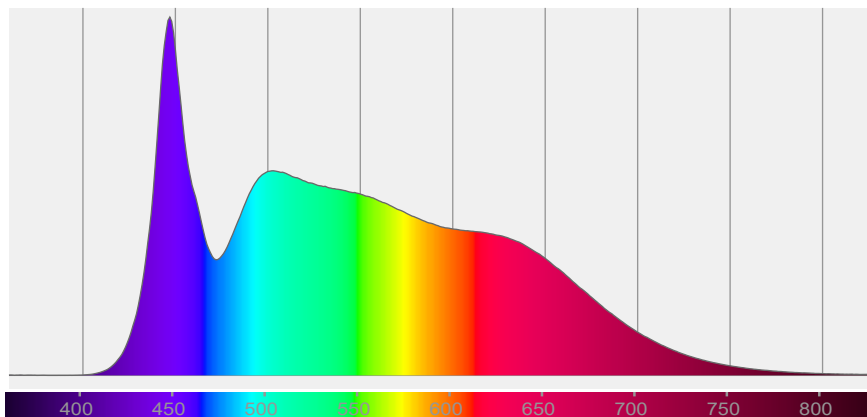

COLOR DETAILS

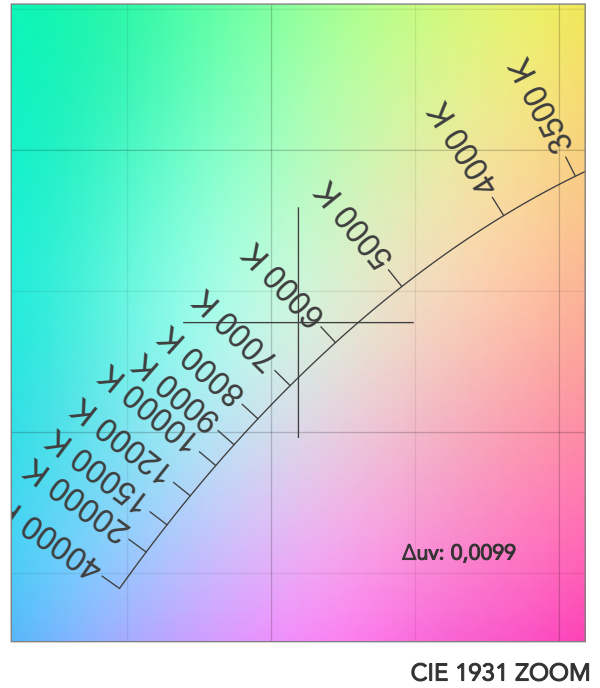
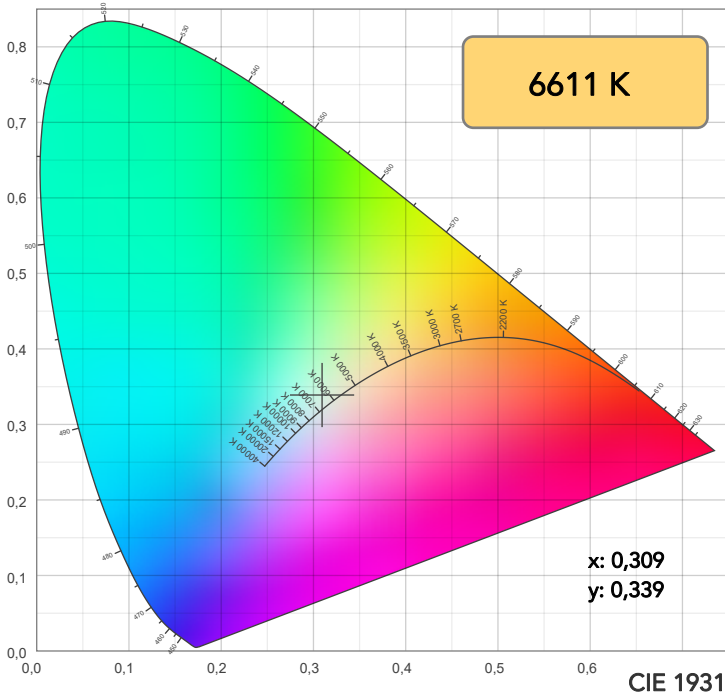

TM30: 93,6

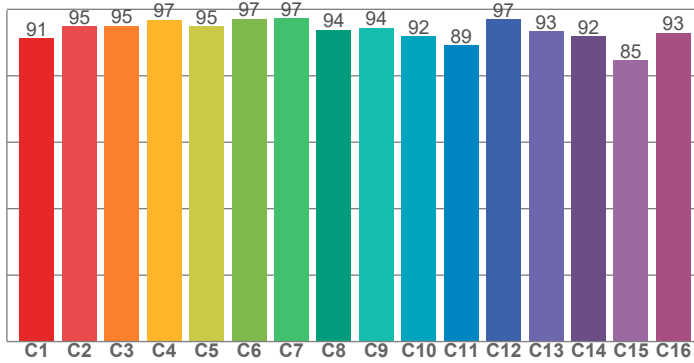

CRI: 93,6 (R1-R8)

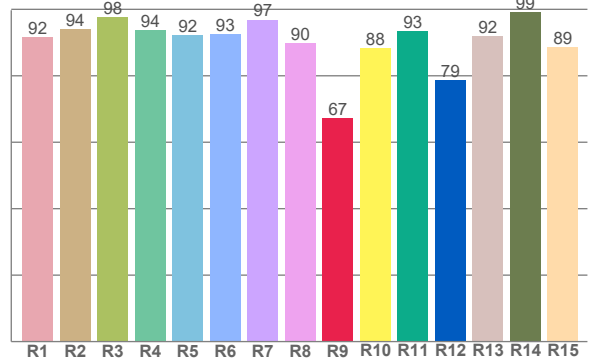

CQS: 95,1

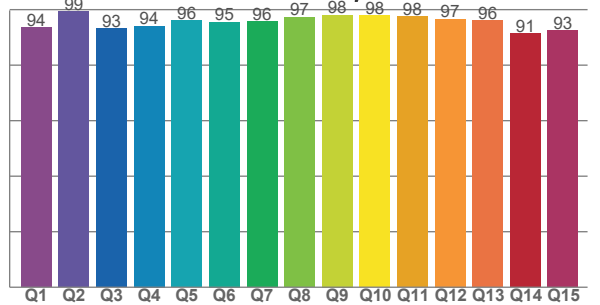

CRI R values, only R1-R8 are used to calculate final CRI value

R1	R2	R3	R4	R5	R6	R7	R8	R9	R10	R11	R12	R13	R14	R15
91,7	94,0	97,7	93,8	92,3	92,6	96,9	89,7	67,2	88,3	93,5	78,7	91,9	99,2	88,7

TM30 C values, 16 binned values out of total of 99 C values

C1	C2	C3	C4	C5	C6	C7	C8	C9	C10	C11	C12	C13	C14	C15	C16
91,3	95,0	95,1	96,8	95,0	97,2	97,4	93,9	94,4	91,8	89,2	97,0	93,3	91,8	84,7	93,0

CQS Q values

Q1	Q2	Q3	Q4	Q5	Q6	Q7	Q8	Q9	Q10	Q11	Q12	Q13	Q14	Q15
93,5	99,3	93,3	94,1	96,0	95,5	95,6	97,3	98,1	97,9	97,5	96,6	96,1	91,5	92,5

COLOR PARAMETERS

Color temperature	Color rendering index	Red component	Color fidelity	Color gamut	Color quality scale	Television lighting index	Color coordinate cie 1931	Color coordinate cie 1931	Color deviation from black body
CCT	CRI	CRI R9	TM30 Rf	TM30 Rg	CQS	TLCI	x	y	Δuv
6611 K	93,6	67,2	93,6	98,3	95,1	98	0,309	0,339	0,0099

TM30 DETAILS

Rf 93,6
Fidelity index Rf

Rg 98,3
Gammut index

Hue Bin	R _f	Graphic shifts (%)	
		Chroma	Hue
1	91	-4%	-2%
2	95	-2%	0%
3	95	-2%	1%
4	97	-2%	0%
5	95	-3%	-1%
6	97	-1%	0%
7	97	-1%	-1%
8	94	-3%	0%
9	94	-3%	3%
10	92	-1%	5%
11	89	1%	6%
12	97	2%	0%
13	93	4%	-3%
14	92	1%	-5%
15	85	6%	-12%
16	93	-2%	-4%

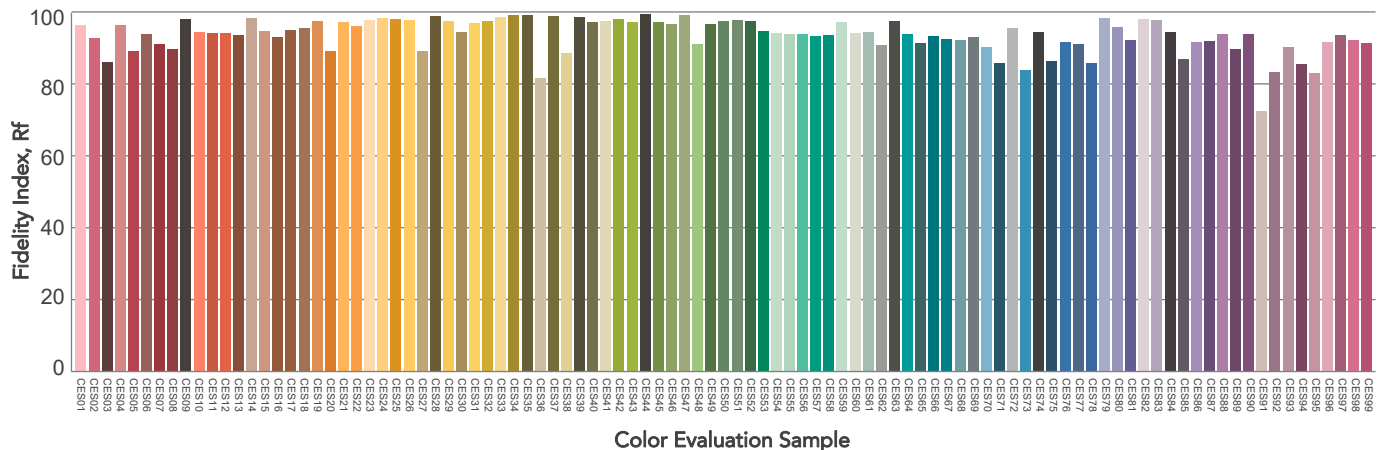
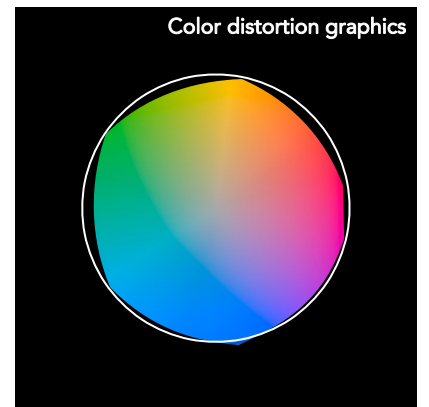
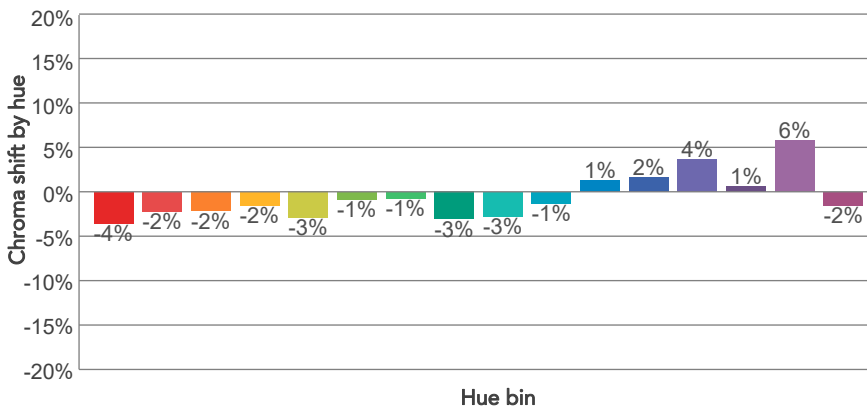
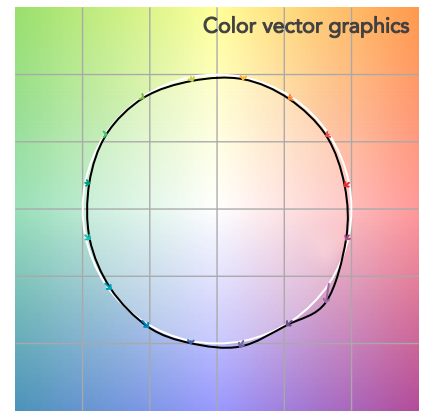
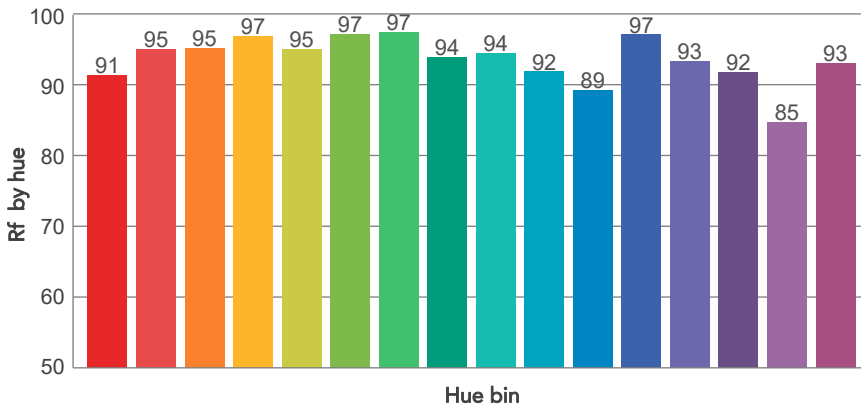
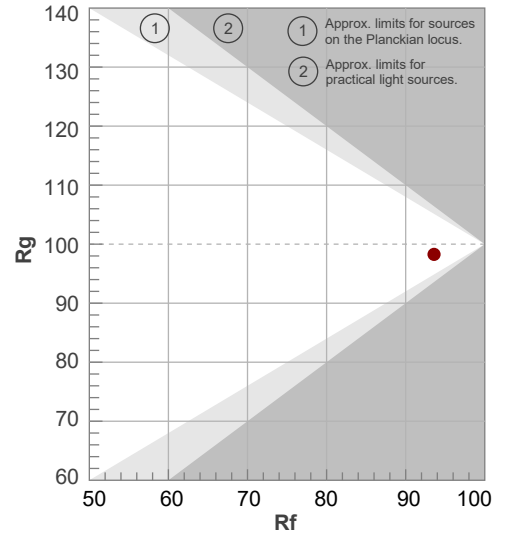

BEAM DETAILS



Beam angle 50%	Field angle 10%	Cut off angle 2,5%	Intensity ratio in 120° cone	Intensity ratio in 90° cone
65,4°	71,2°	72,7°	99,7%	99,7%

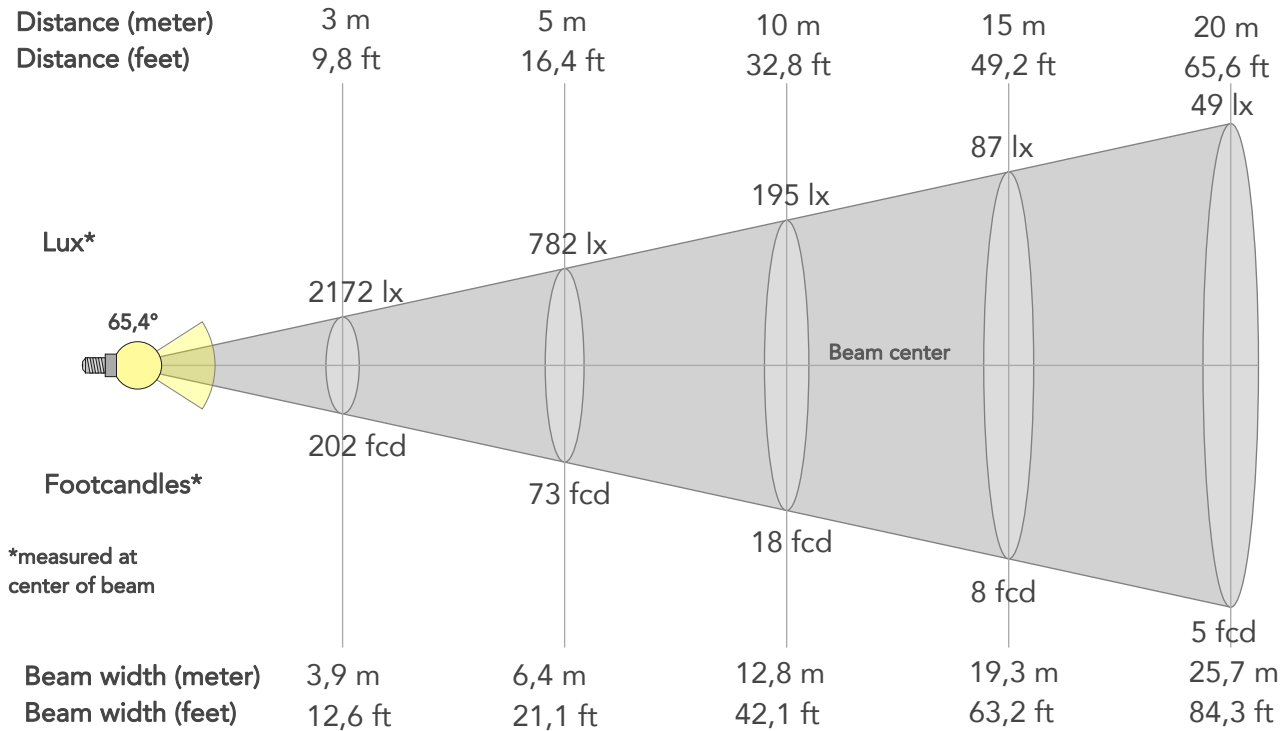

BEAM INTENSITIES AND WIDTHS

Distance	1m	2m	3m	4m	5m	7,5m	10m	15m	20m	25m	30m	40m	50m
Distance	3,3ft	6,6ft	9,8ft	13,1ft	16,4ft	24,6ft	32,8ft	49,2ft	65,6ft	82ft	98,4ft	131,2ft	164ft
Lux	19545lx	4886lx	2172lx	1222lx	782lx	347lx	195lx	87lx	49lx	31lx	22lx	12lx	8lx
Footcand.	1816fcd	454fcd	202fcd	113fcd	73fcd	32fcd	18fcd	8fcd	5fcd	3fcd	2fcd	1fcd	1fcd
Beam wid.	1,3m	2,6m	3,9m	5,1m	6,4m	9,6m	12,8m	19,3m	25,7m	32,1m	38,5m	51,4m	64,2m
Beam wid.	4,2ft	8,5ft	12,6ft	16,8ft	21,1ft	31,6ft	42,1ft	63,2ft	84,3ft	105,3ft	126,4ft	168,5ft	210,7ft

LINEAR DISTRIBUTION DIAGRAM

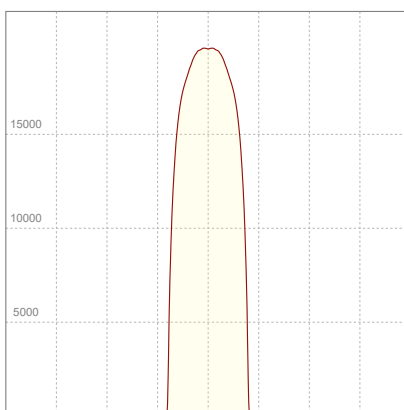

ELECTRICAL SPECIFICATIONS

Input voltage	Input current	Input power	Power FC	Efficiency
226V	1,73A	378,4W	0,97	47lm/W

ISO DIAGRAMS

ISO CANDELA DIAGRAM

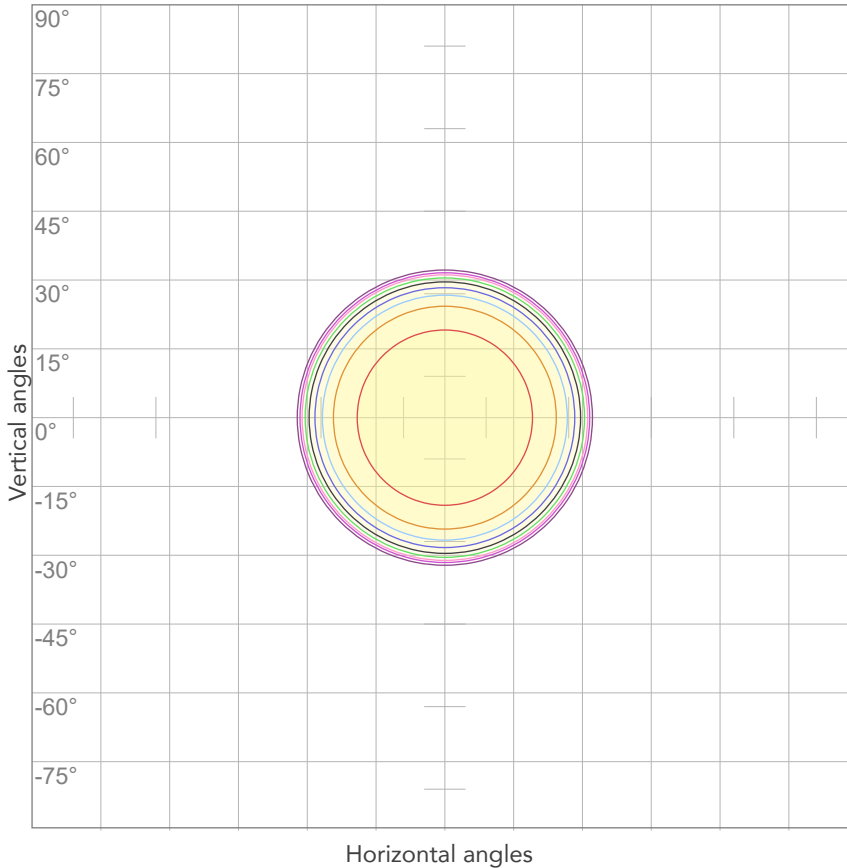

10%	1955 cd
20%	3909 cd
30%	5864 cd
40%	7818 cd
50%	9773 cd
60%	11727 cd
70%	13682 cd
80%	15636 cd

Conditions:

Number of c-planes: 2

Candela at center: 19545 cd

ISO LUX DIAGRAM

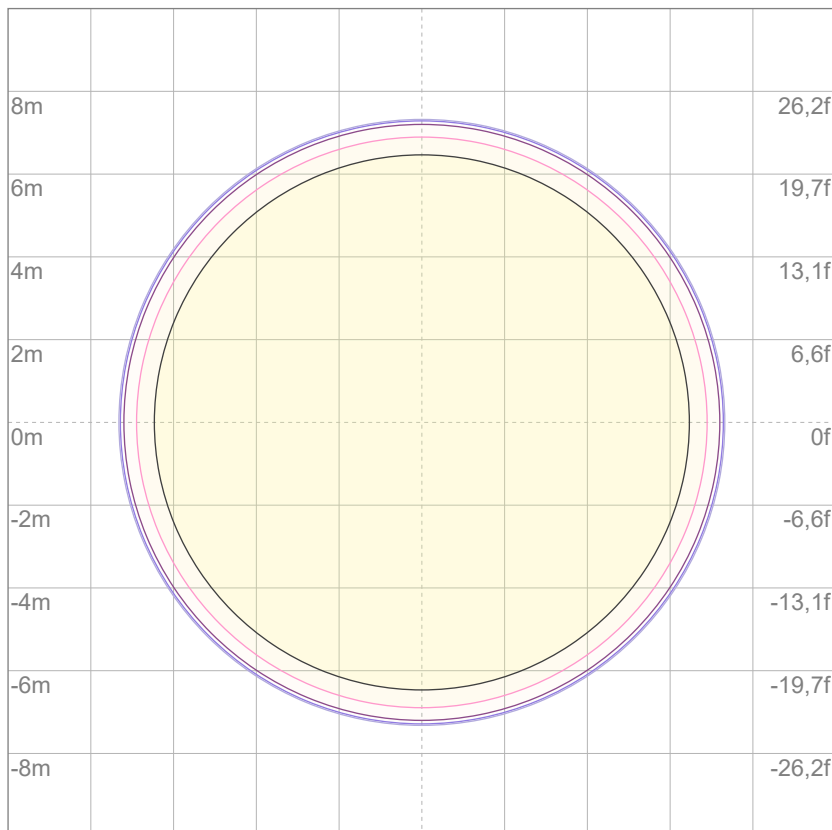

3%	5,86 lx
5%	9,77 lx
10%	19,5 lx
30%	58,6 lx
50%	97,7 lx

Conditions:

Number of c-planes: 2

Lux at center: 195 lx

Lux distribution on a surface when lamp is mounted at 10 meters from the surface.

Mounting height: 10 meters (33 feet)



Total lumen output:

15466 lm

Peak candela output:

17072 cd

Light quality:

CRI: 97,0

Color temperature:

2828 K

PRODUCT NAME:

ECLFWHPVW

MEASURAMENT CONDITIONS:

Beam angle:

PRL70

Target:

2800K

Operator:

Giuseppe della Peruta

Date and time:

08/01/2026 17:36:07

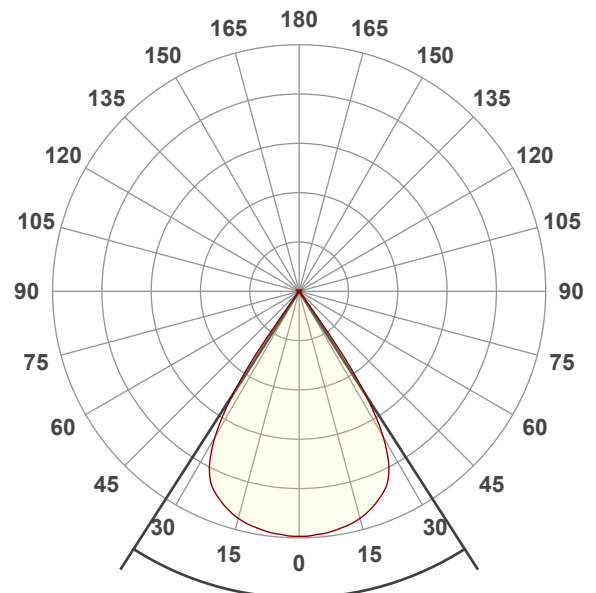

Beam angle 50%: 65,4°

Field angle 10%: 71,2°

Cut off angle 2.5%: 72,6°

Spectra

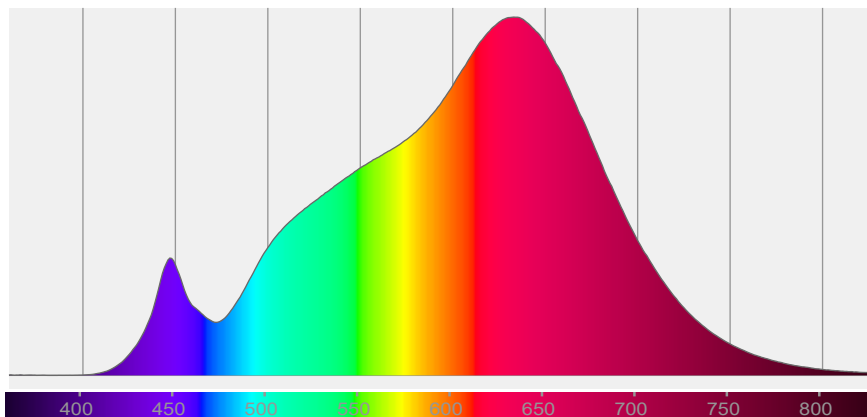

COLOR DETAILS

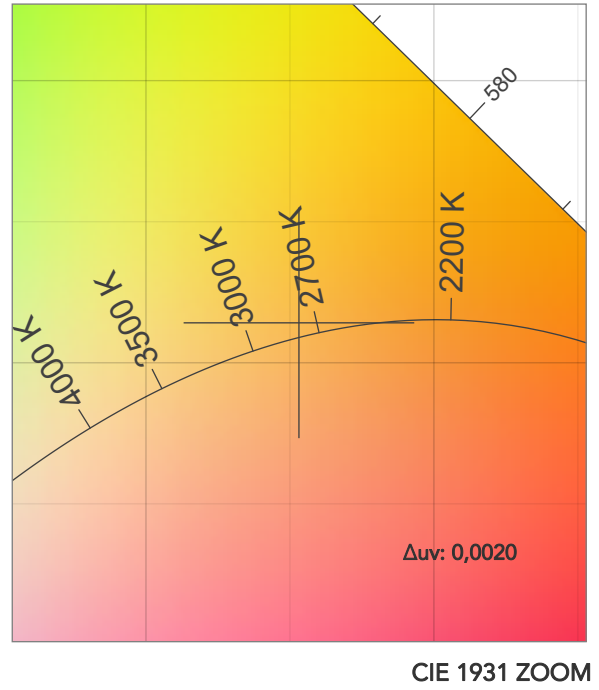
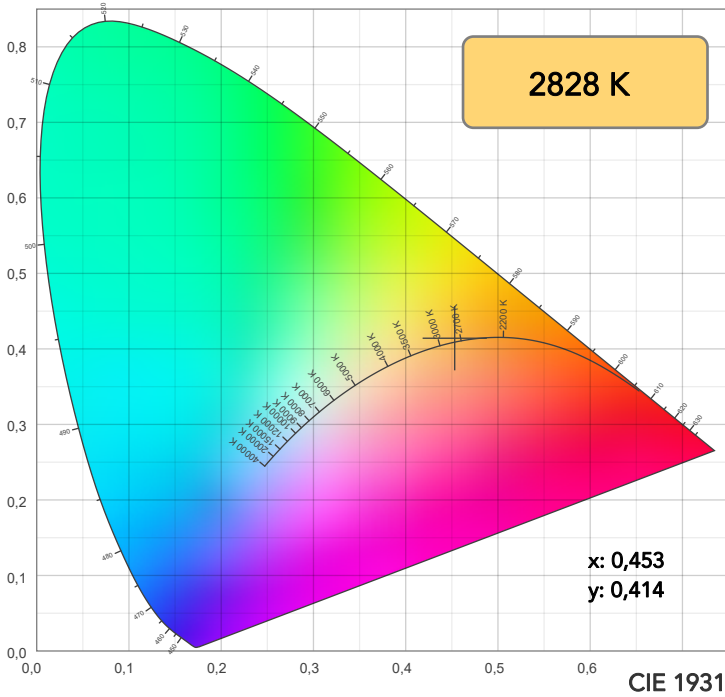

TM30: 95,9

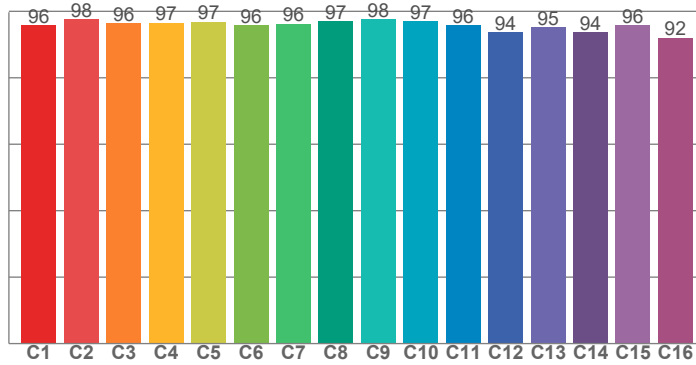

CRI: 97,0 (R1-R8)

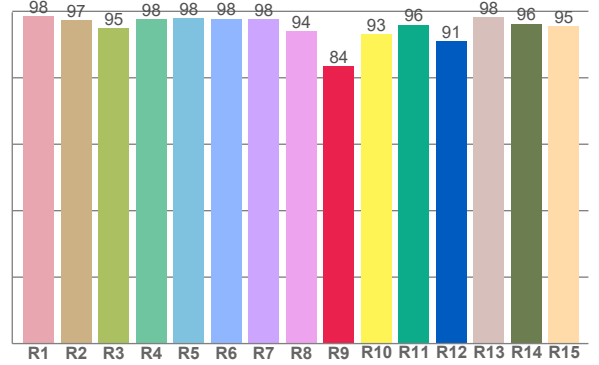

CQS: 94,5

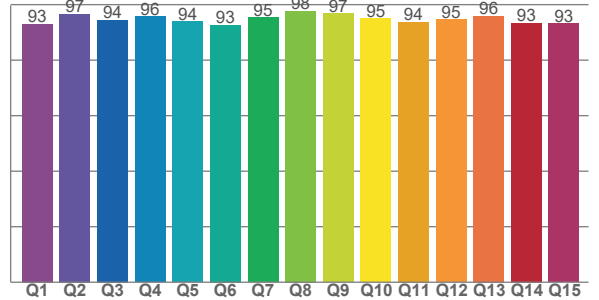

CRI R values, only R1-R8 are used to calculate final CRI value

R1	R2	R3	R4	R5	R6	R7	R8	R9	R10	R11	R12	R13	R14	R15
98,5	97,4	95,0	97,6	97,9	97,8	97,7	94,0	83,5	93,2	96,0	91,0	98,1	96,3	95,5

TM30 C values, 16 binned values out of total of 99 C values

C1	C2	C3	C4	C5	C6	C7	C8	C9	C10	C11	C12	C13	C14	C15	C16
95,8	97,6	96,4	96,5	96,8	95,8	96,3	97,0	97,5	97,0	95,7	93,7	95,2	93,6	95,8	92,0

CQS Q values

Q1	Q2	Q3	Q4	Q5	Q6	Q7	Q8	Q9	Q10	Q11	Q12	Q13	Q14	Q15
93,0	96,6	94,4	95,8	94,0	92,7	95,5	97,7	96,7	95,1	93,8	94,7	96,0	93,3	93,3

COLOR PARAMETERS

Color temperature	Color rendering index	Red component	Color fidelity	Color gamut	Color quality scale	Television lighting index	Color coordinate cie 1931	Color coordinate cie 1931	Color deviation from black body
CCT	CRI	CRI R9	TM30 Rf	TM30 Rg	CQS	TLCI	x	y	Δuv
2828 K	97,0	83,5	95,9	101,0	94,5	97	0,453	0,414	0,0020

TM30 DETAILS

Rf 95,9
Fidelity index Rf

Rg 101,0
Gammut index

Hue Bin	R _f	Graphic shifts (%)	
		Chroma	Hue
1	96	-2%	-1%
2	98	-1%	0%
3	96	-1%	2%
4	97	0%	1%
5	97	1%	2%
6	96	2%	1%
7	96	1%	-2%
8	97	2%	-1%
9	98	0%	-1%
10	97	-1%	0%
11	96	0%	3%
12	94	2%	0%
13	95	2%	-3%
14	94	3%	-4%
15	96	0%	-3%
16	92	0%	-6%

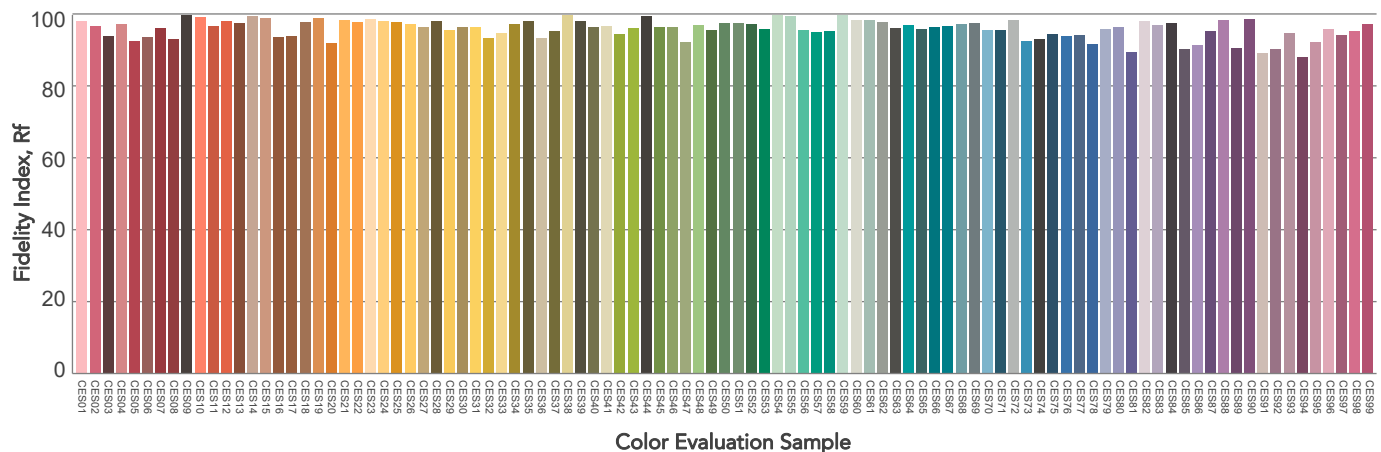
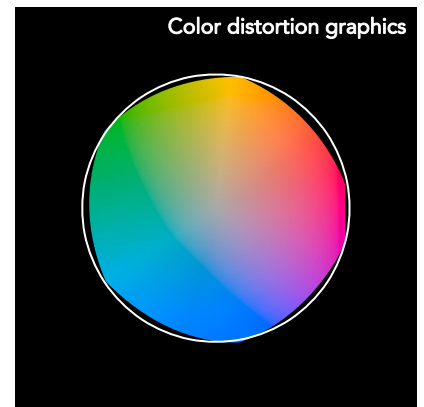
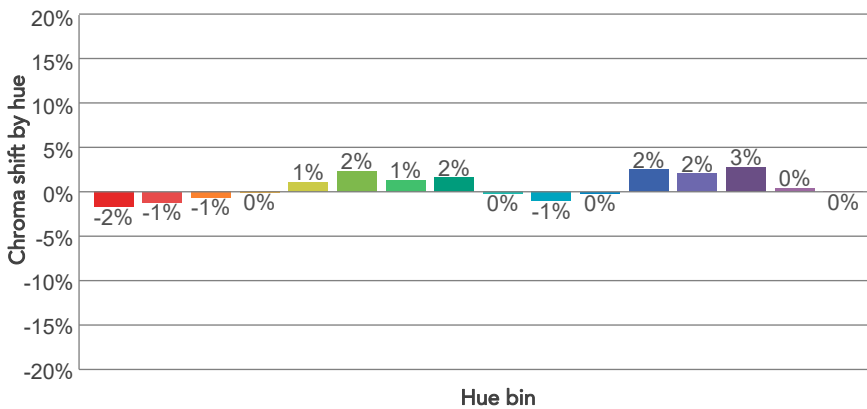
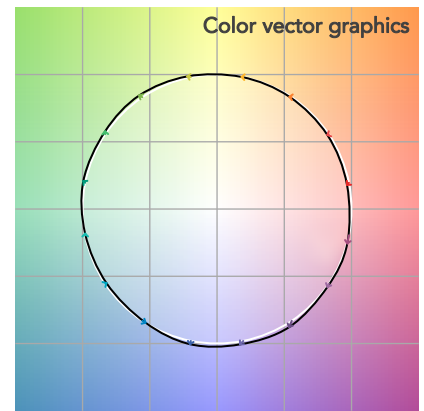
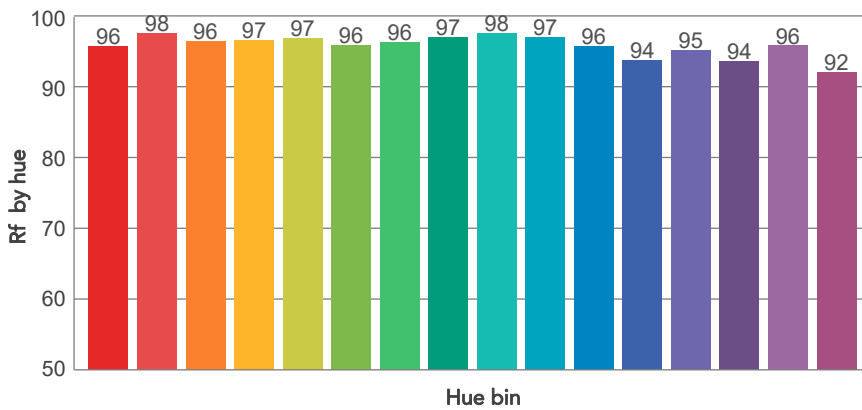
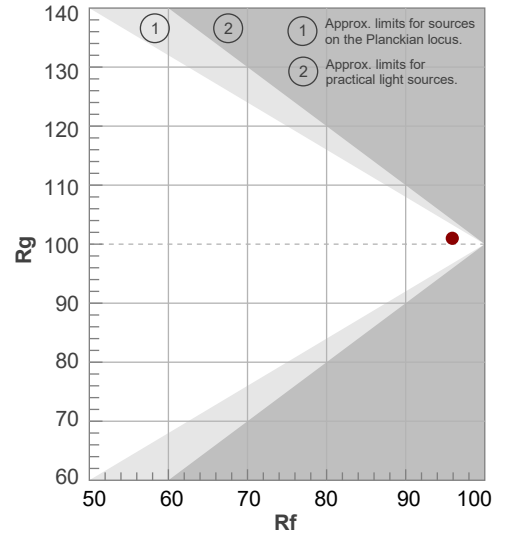

BEAM DETAILS



Beam angle 50%	Field angle 10%	Cut off angle 2,5%	Intensity ratio in 120° cone	Intensity ratio in 90° cone
65,4°	71,2°	72,6°	99,7%	99,7%

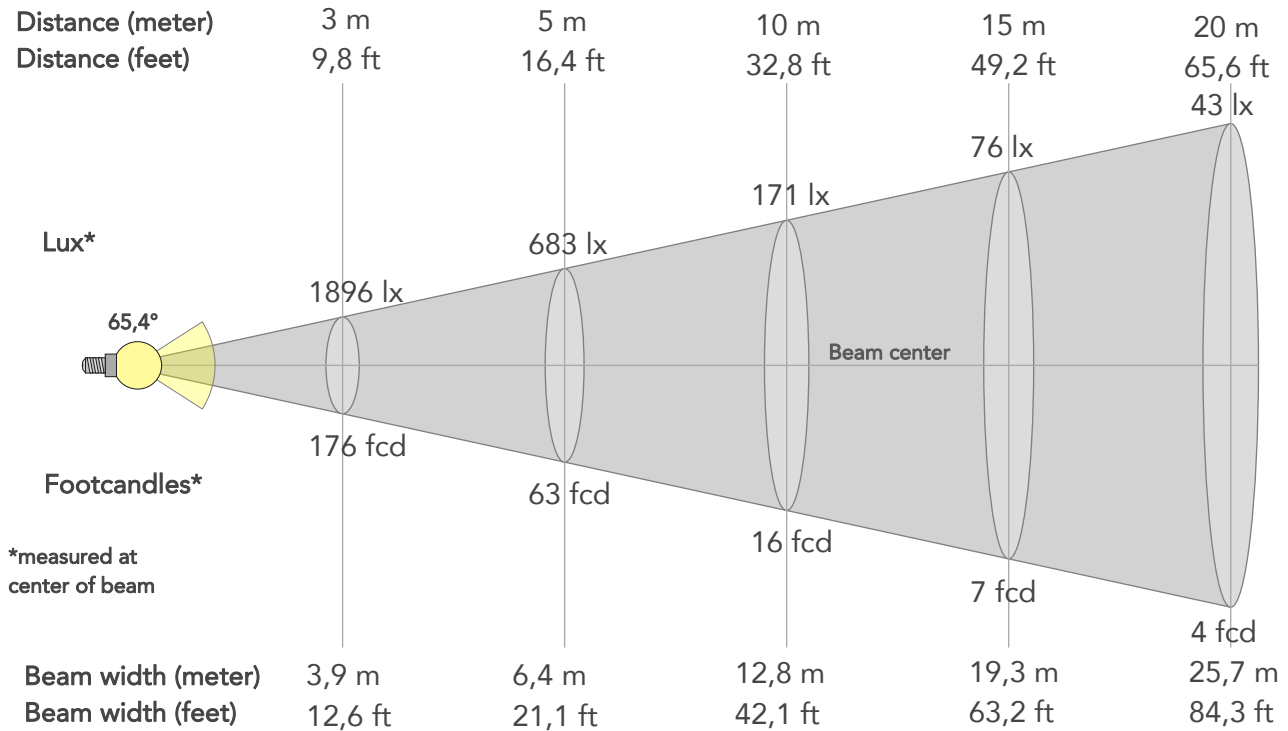

BEAM INTENSITIES AND WIDTHS

Distance	1m	2m	3m	4m	5m	7,5m	10m	15m	20m	25m	30m	40m	50m
Distance	3,3ft	6,6ft	9,8ft	13,1ft	16,4ft	24,6ft	32,8ft	49,2ft	65,6ft	82ft	98,4ft	131,2ft	164ft
Lux	17068lx	4267lx	1896lx	1067lx	683lx	303lx	171lx	76lx	43lx	27lx	19lx	11lx	7lx
Footcand.	1586fcd	396fcd	176fcd	99fcd	63fcd	28fcd	16fcd	7fcd	4fcd	3fcd	2fcd	1fcd	1fcd
Beam wid.	1,3m	2,6m	3,9m	5,1m	6,4m	9,6m	12,8m	19,3m	25,7m	32,1m	38,5m	51,4m	64,2m
Beam wid.	4,2ft	8,5ft	12,6ft	16,8ft	21,1ft	31,6ft	42,1ft	63,2ft	84,3ft	105,4ft	126,4ft	168,6ft	210,7ft

LINEAR DISTRIBUTION DIAGRAM

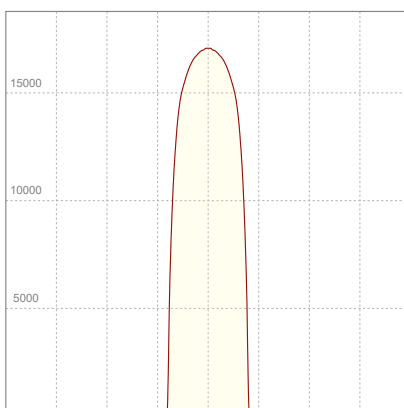

ELECTRICAL SPECIFICATIONS

Input voltage	Input current	Input power	Power FC	Efficiency
226V	1,87A	410,6W	0,97	38lm/W

ISO DIAGRAMS

ISO CANDELA DIAGRAM

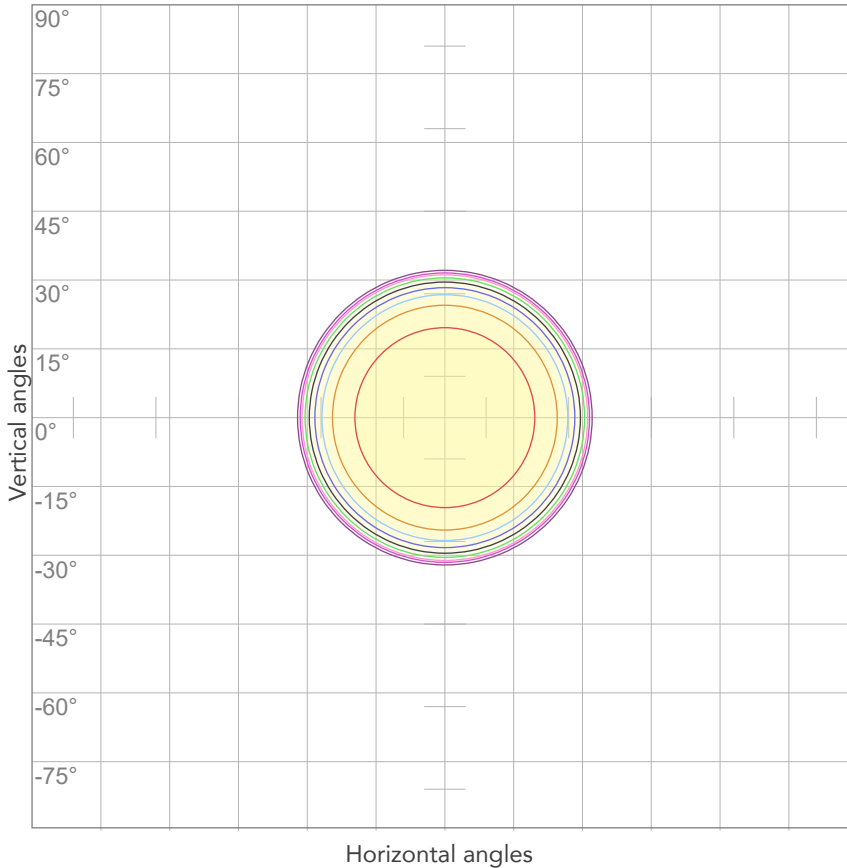

10%	1707 cd
20%	3414 cd
30%	5121 cd
40%	6827 cd
50%	8534 cd
60%	10241 cd
70%	11948 cd
80%	13655 cd

Conditions:

Number of c-planes: 2

Candela at center: 17068 cd

ISO LUX DIAGRAM

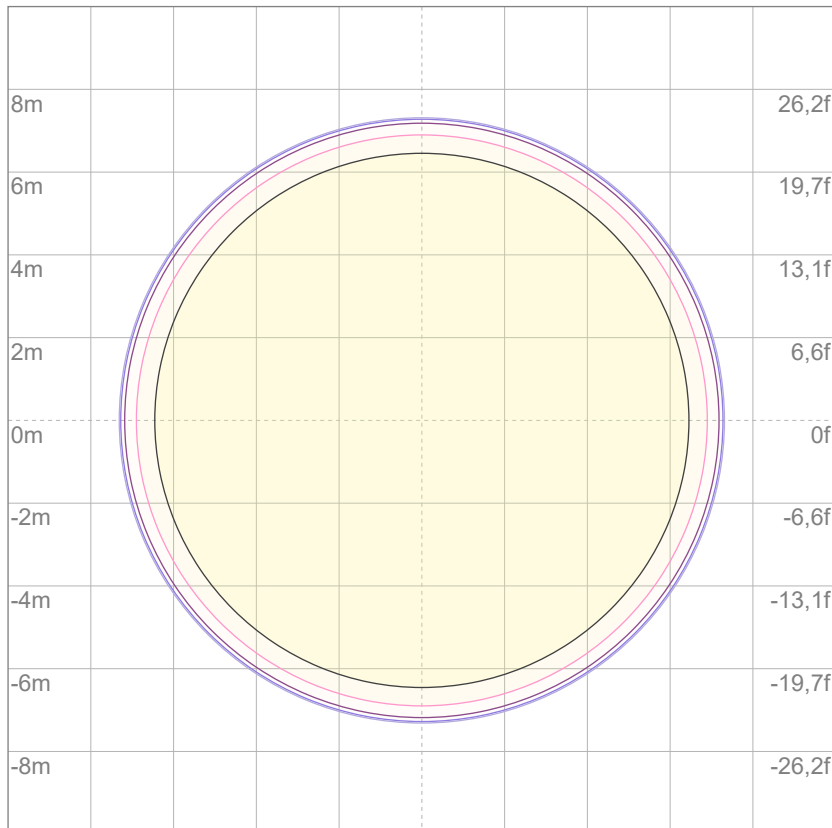

3%	5,12 lx
5%	8,53 lx
10%	17,1 lx
30%	51,2 lx
50%	85,3 lx

Conditions:

Number of c-planes: 2

Lux at center: 171 lx

Lux distribution on a surface when lamp is mounted at 10 meters from the surface.

Mounting height: 10 meters (33 feet)



Total lumen output:

17186 lm

Peak candela output:

18973 cd

Light quality:

CRI: 97,7

Color temperature:

3243 K

PRODUCT NAME:

ECLFWHPVW

MEASURAMENT CONDITIONS:

Beam angle:

PRL70

Target:

3200K

Operator:

Giuseppe della Peruta

Date and time:

08/01/2026 17:39:10

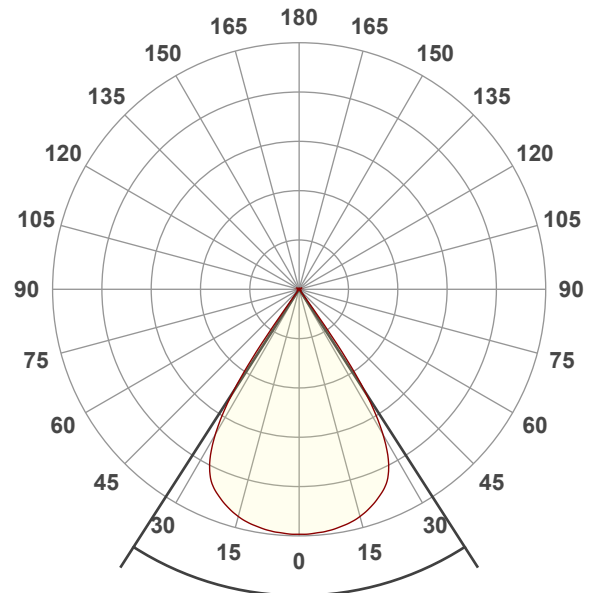

Beam angle 50%: 65,5°

Field angle 10%: 71,3°

Cut off angle 2.5%: 72,8°

Spectra

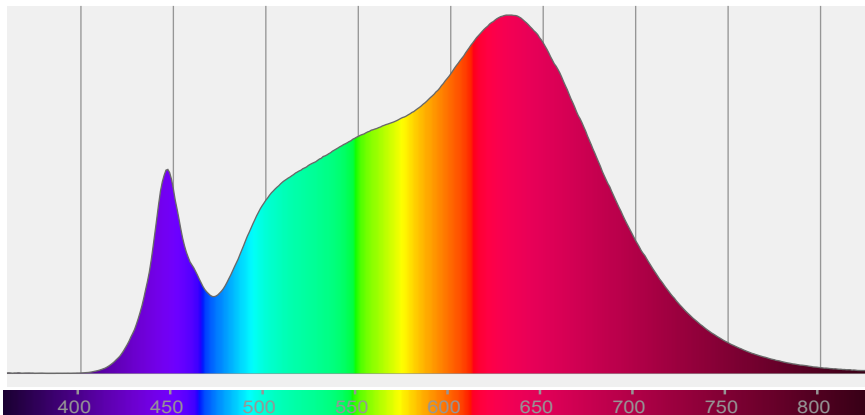

COLOR DETAILS

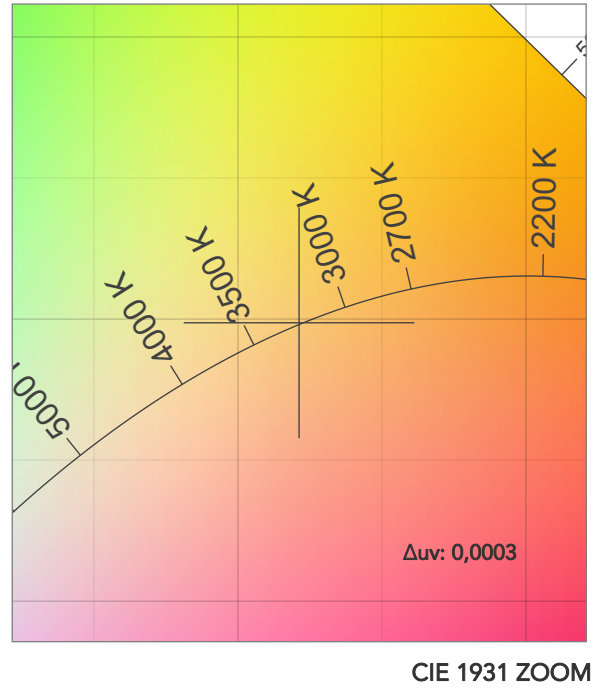
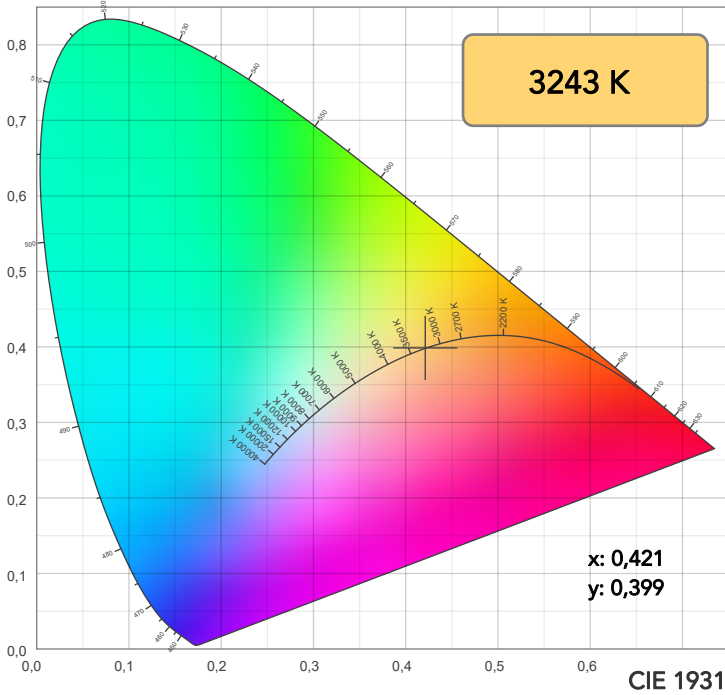

TM30: 96,0

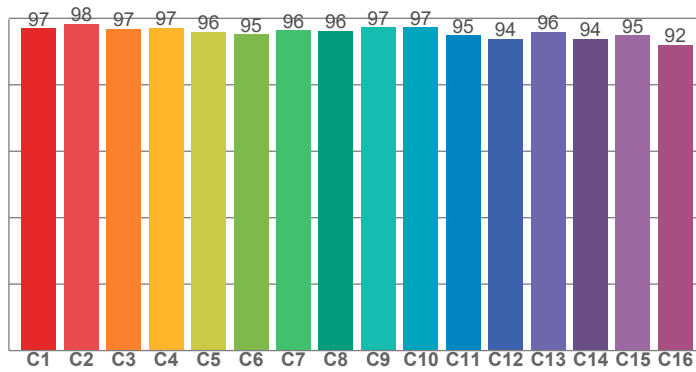

CRI: 97,7 (R1-R8)

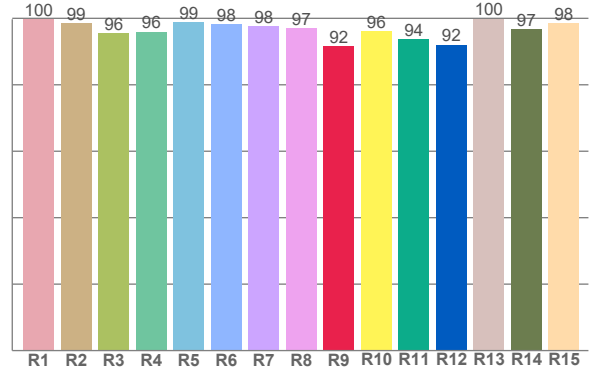

CRI R values, only R1-R8 are used to calculate final CRI value

R1	R2	R3	R4	R5	R6	R7	R8	R9	R10	R11	R12	R13	R14	R15
99,7	98,6	95,6	96,0	99,0	98,2	97,6	97,1	91,7	96,1	93,8	92,1	99,9	96,8	98,5

TM30 C values, 16 binned values out of total of 99 C values

C1	C2	C3	C4	C5	C6	C7	C8	C9	C10	C11	C12	C13	C14	C15	C16
97,0	98,4	96,9	97,2	95,9	95,2	96,4	96,3	97,3	97,4	94,8	93,9	95,9	93,9	94,8	92,0

CQS Q values

Q1	Q2	Q3	Q4	Q5	Q6	Q7	Q8	Q9	Q10	Q11	Q12	Q13	Q14	Q15
95,5	98,2	94,1	97,2	95,2	92,8	95,5	98,4	97,8	97,2	98,2	98,0	98,2	96,7	96,2

CQS: 96,1

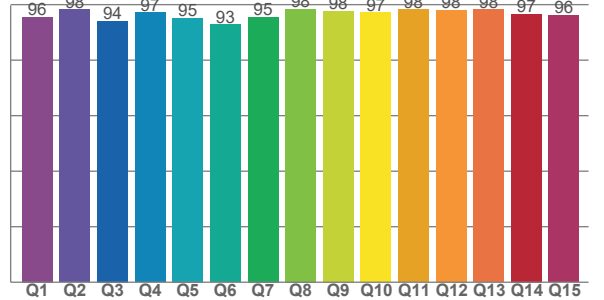

COLOR PARAMETERS

Color temperature	Color rendering index	Red component	Color fidelity	Color gamut	Color quality scale	Television lighting index	Color coordinate cie 1931	Color coordinate cie 1931	Color deviation from black body
CCT	CRI	CRI R9	TM30 Rf	TM30 Rg	CQS	TLCI	x	y	Δuv
3243 K	97,7	91,7	96,0	102,4	96,1	98	0,421	0,399	0,0003

TM30 DETAILS

Rf 96,0
Fidelity index Rf

Rg 102,4
Gammut index

Hue Bin	R _f	Graphic shifts (%)	
		Chroma	Hue
1	97	-1%	-1%
2	98	0%	0%
3	97	0%	1%
4	97	0%	1%
5	96	1%	2%
6	95	3%	1%
7	96	2%	-1%
8	96	2%	-1%
9	97	0%	-1%
10	97	-1%	0%
11	95	1%	3%
12	94	3%	0%
13	96	2%	-2%
14	94	4%	-3%
15	95	1%	-3%
16	92	2%	-6%

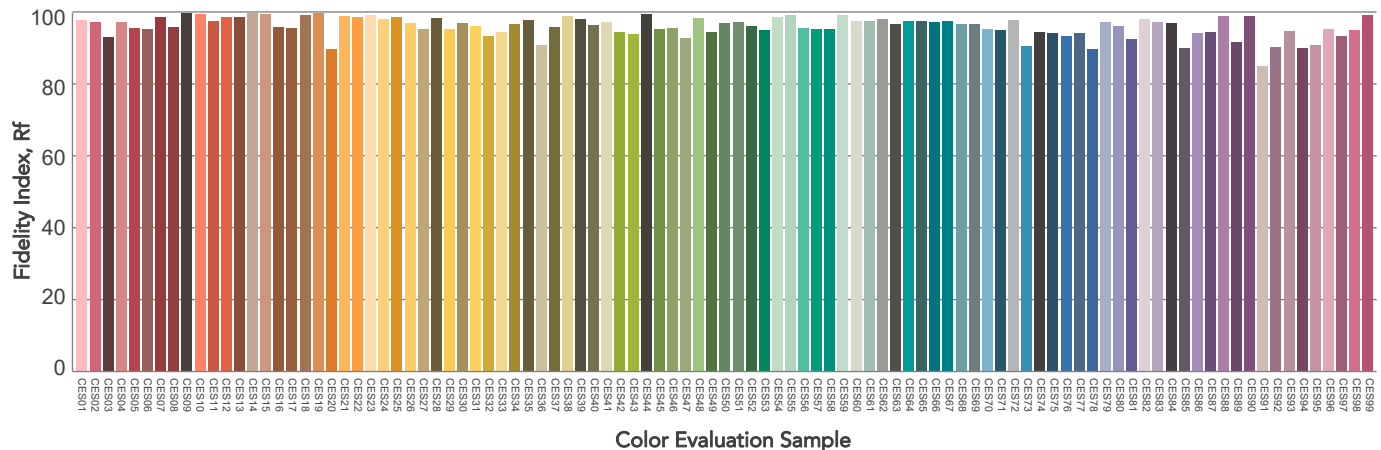
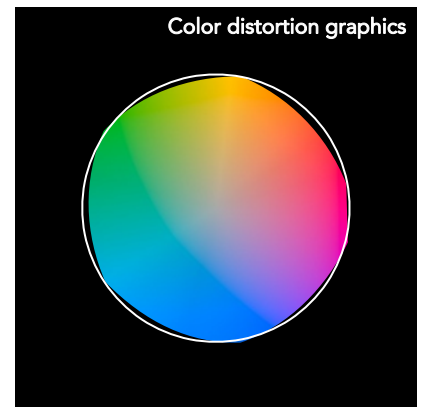
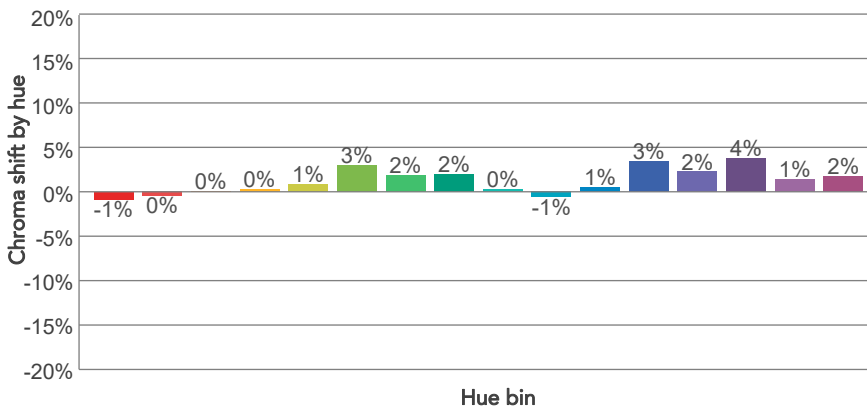
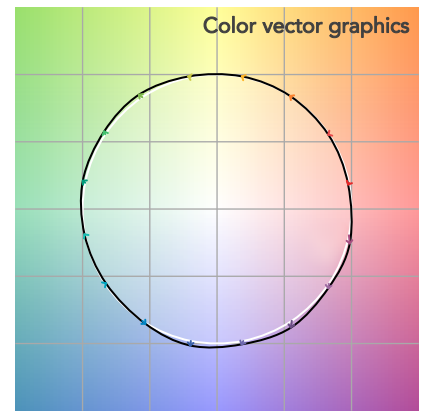
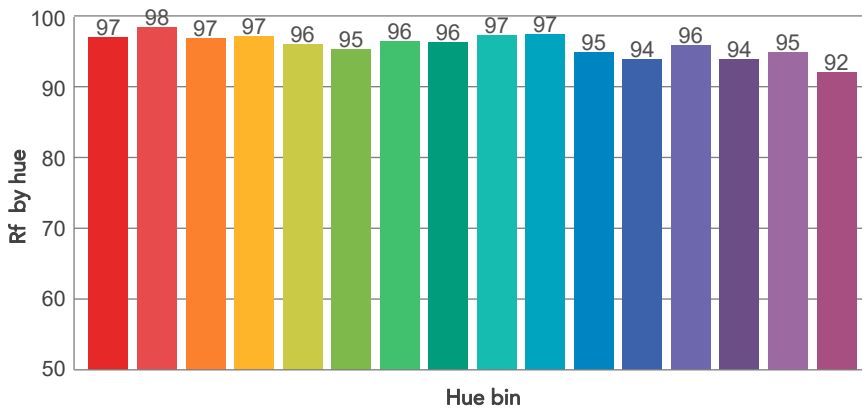
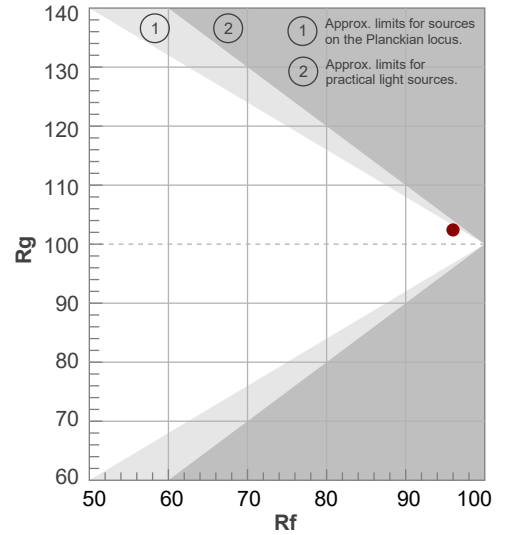

BEAM DETAILS



Beam angle 50%	Field angle 10%	Cut off angle 2,5%	Intensity ratio in 120° cone	Intensity ratio in 90° cone
65,5°	71,3°	72,8°	99,8%	99,7%

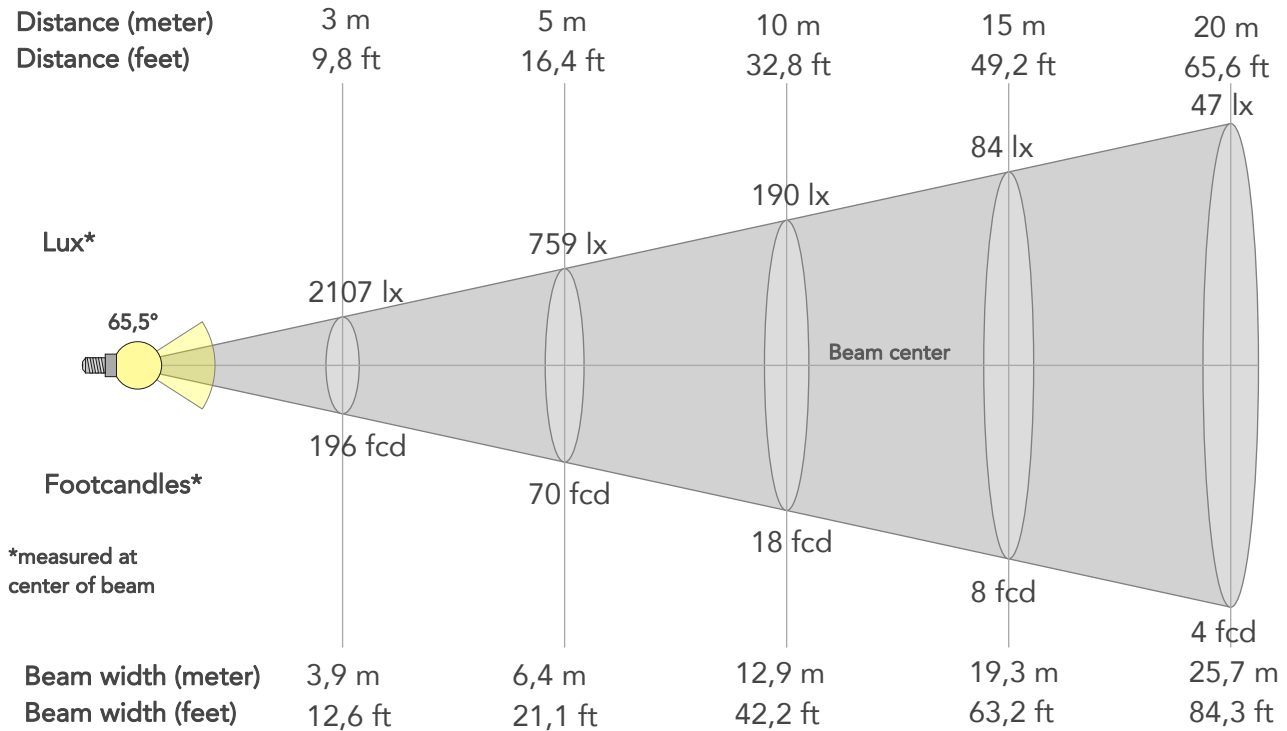

BEAM INTENSITIES AND WIDTHS

Distance	1m	2m	3m	4m	5m	7,5m	10m	15m	20m	25m	30m	40m	50m
Distance	3,3ft	6,6ft	9,8ft	13,1ft	16,4ft	24,6ft	32,8ft	49,2ft	65,6ft	82ft	98,4ft	131,2ft	164ft
Lux	18967lx	4742lx	2107lx	1185lx	759lx	337lx	190lx	84lx	47lx	30lx	21lx	12lx	8lx
Footcand.	1762fcd	441fcd	196fcd	110fcd	70fcd	31fcd	18fcd	8fcd	4fcd	3fcd	2fcd	1fcd	1fcd
Beam wid.	1,3m	2,6m	3,9m	5,1m	6,4m	9,6m	12,9m	19,3m	25,7m	32,1m	38,6m	51,4m	64,3m
Beam wid.	4,2ft	8,5ft	12,6ft	16,8ft	21,1ft	31,6ft	42,2ft	63,2ft	84,3ft	105,4ft	126,5ft	168,6ft	210,8ft

LINEAR DISTRIBUTION DIAGRAM

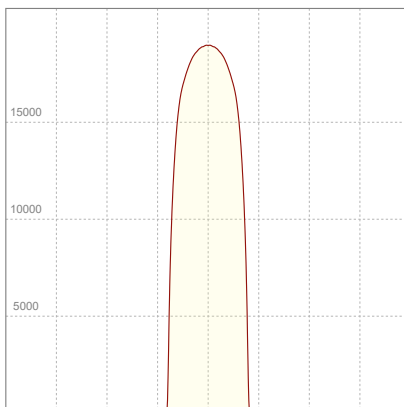

ELECTRICAL SPECIFICATIONS

Input voltage	Input current	Input power	Power FC	Efficiency
226V	1,98A	436W	0,97	39lm/W

ISO DIAGRAMS

ISO CANDELA DIAGRAM

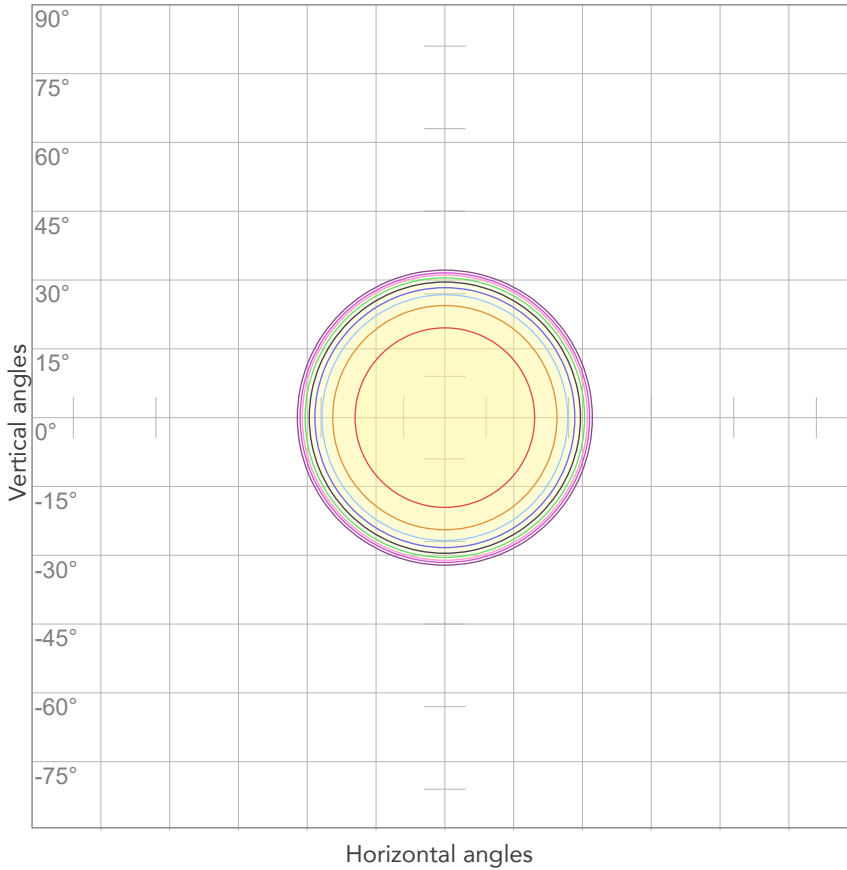

10%	1897 cd
20%	3793 cd
30%	5690 cd
40%	7587 cd
50%	9483 cd
60%	11380 cd
70%	13277 cd
80%	15173 cd

Conditions:

Number of c-planes: 2

Candela at center: 18967 cd

ISO LUX DIAGRAM

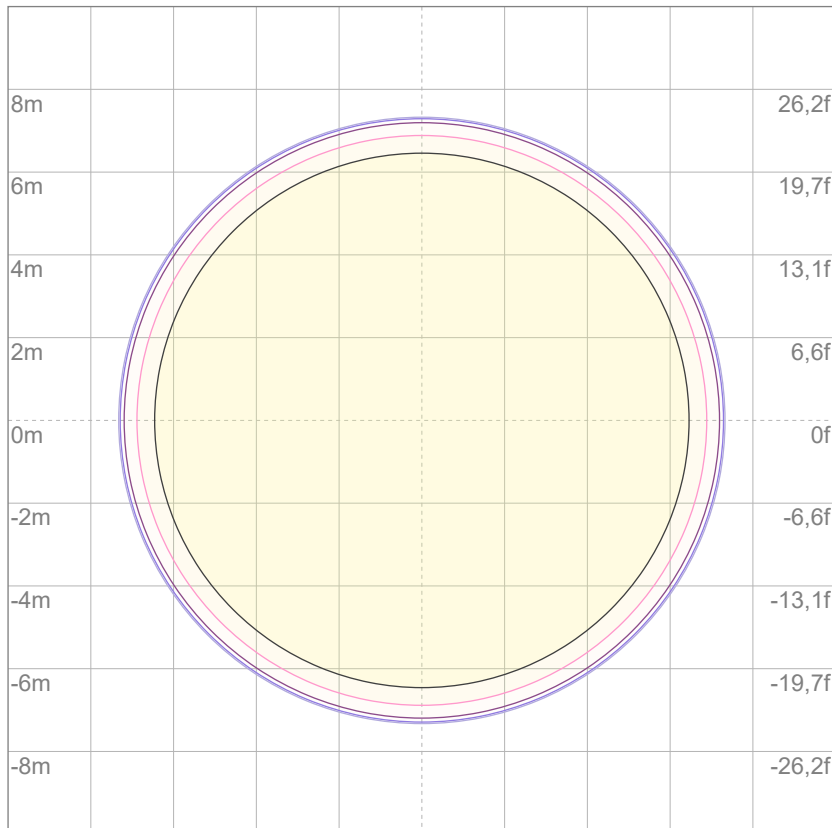

3%	5,69 lx
5%	9,48 lx
10%	19,0 lx
30%	56,9 lx
50%	94,8 lx

Conditions:

Number of c-planes: 2

Lux at center: 190 lx

Lux distribution on a surface when lamp is mounted at 10 meters from the surface.



Total lumen output:

17966 lm

Peak candela output:

19870 cd

Light quality:

CRI: 98,0

Color temperature:

4040 K

PRODUCT NAME:

ECLFWHPVW

MEASURAMENT CONDITIONS:

Beam angle:

PRL70

Target:

4000K

Operator:

Giuseppe della Peruta

Date and time:

08/01/2026 17:44:58

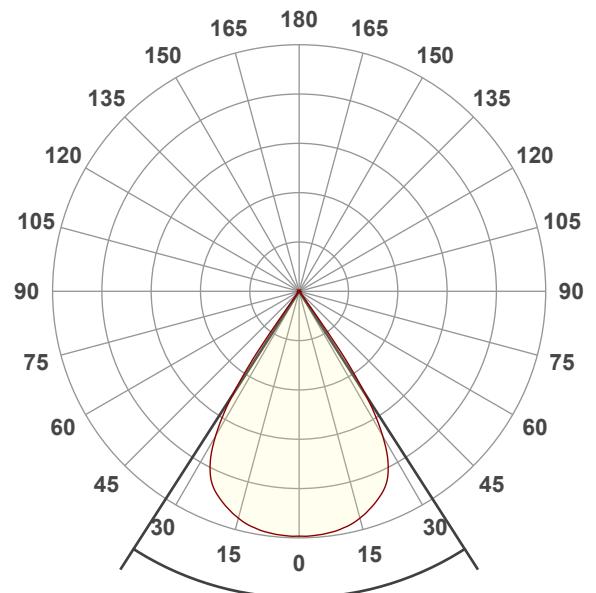

Beam angle 50%: 65,4°

Field angle 10%: 71,2°

Cut off angle 2.5%: 72,7°

Spectra

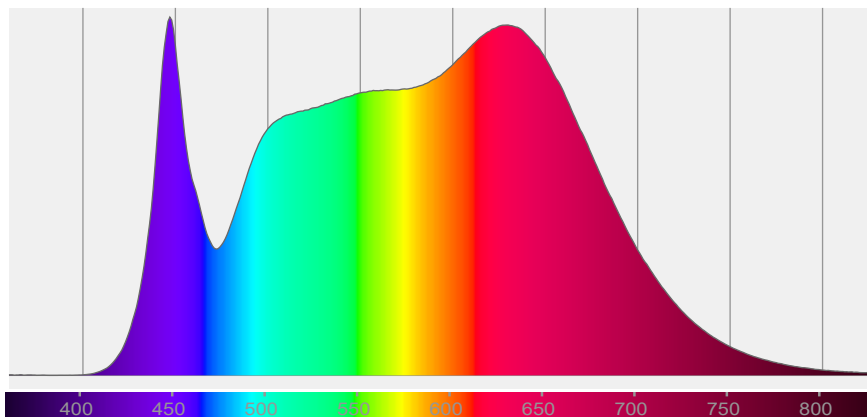

COLOR DETAILS

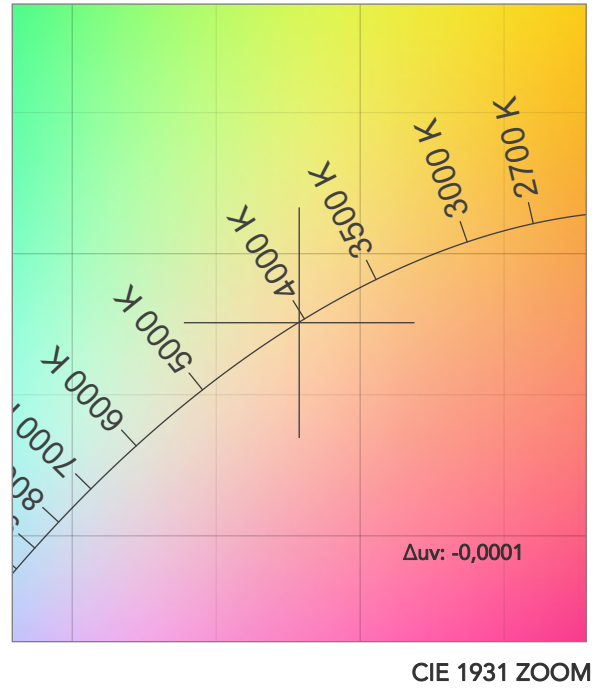
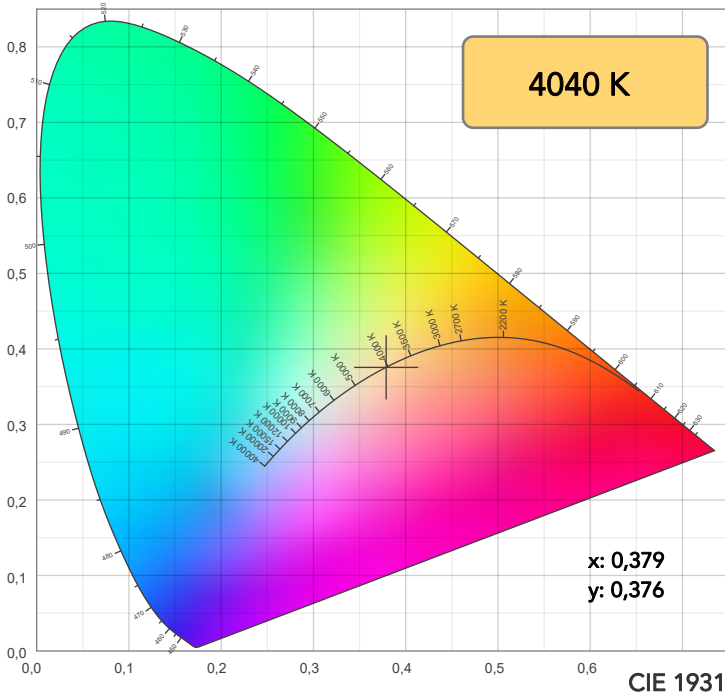

TM30: 96,1

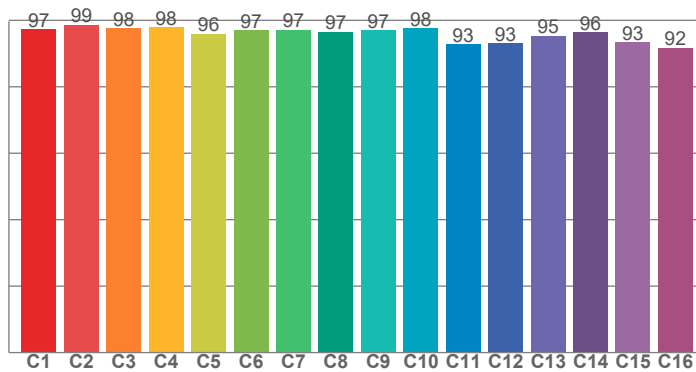

CRI: 98,0 (R1-R8)

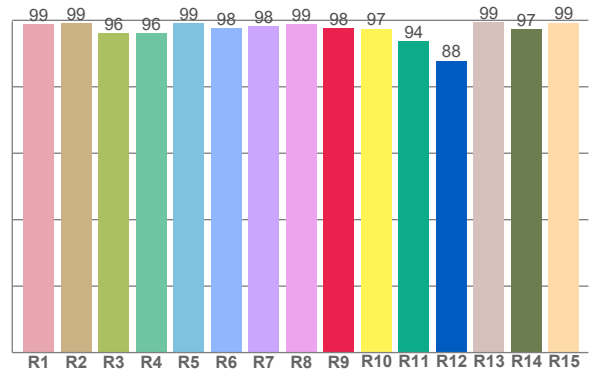

CRI R values, only R1-R8 are used to calculate final CRI value

R1	R2	R3	R4	R5	R6	R7	R8	R9	R10	R11	R12	R13	R14	R15
98,9	99,1	96,1	96,2	99,2	97,6	98,1	98,9	97,5	97,5	93,8	87,9	99,4	97,4	99,3

TM30 C values, 16 binned values out of total of 99 C values

C1	C2	C3	C4	C5	C6	C7	C8	C9	C10	C11	C12	C13	C14	C15	C16
97,4	98,6	97,6	97,8	96,0	97,0	97,2	96,6	97,0	97,6	92,7	93,0	95,3	96,4	93,3	91,7

CQS Q values

Q1	Q2	Q3	Q4	Q5	Q6	Q7	Q8	Q9	Q10	Q11	Q12	Q13	Q14	Q15
98,5	99,6	93,9	97,0	98,2	95,9	97,8	99,6	98,8	98,7	99,8	99,1	99,1	99,3	99,0

CQS: 97,7

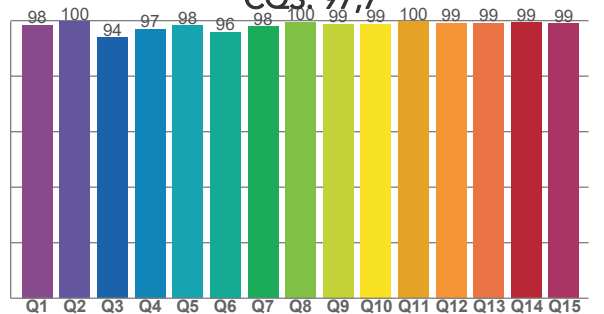

COLOR PARAMETERS

Color temperature	Color rendering index	Red component	Color fidelity	Color gamut	Color quality scale	Television lighting index	Color coordinate cie 1931	Color coordinate cie 1931	Color deviation from black body
CCT	CRI	CRI R9	TM30 Rf	TM30 Rg	CQS	TLCI	x	y	Δuv
4040 K	98,0	97,5	96,1	102,1	97,7	98	0,379	0,376	-0,0001

TM30 DETAILS

Rf 96,1
Fidelity index Rf

Rg 102,1
Gammut index

Hue Bin	R _f	Graphic shifts (%)	
		Chroma	Hue
1	97	0%	-1%
2	99	0%	0%
3	98	0%	1%
4	98	-1%	0%
5	96	-1%	1%
6	97	2%	1%
7	97	1%	1%
8	97	1%	1%
9	97	0%	1%
10	98	0%	1%
11	93	2%	4%
12	93	3%	2%
13	95	3%	-1%
14	96	3%	0%
15	93	3%	-4%
16	92	2%	-5%

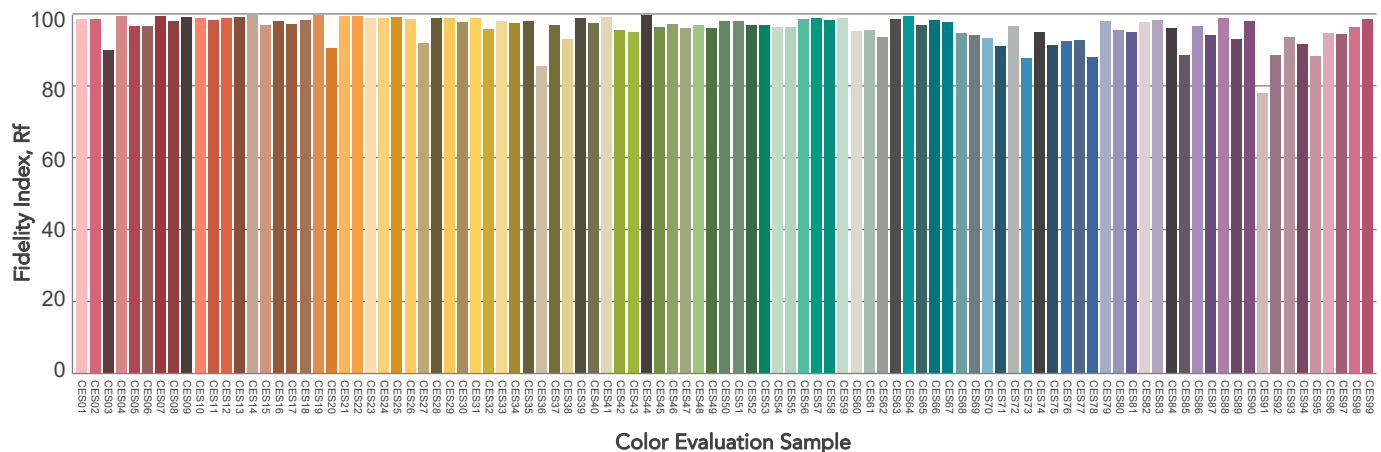
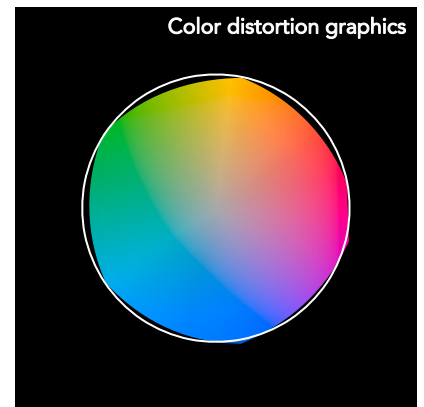
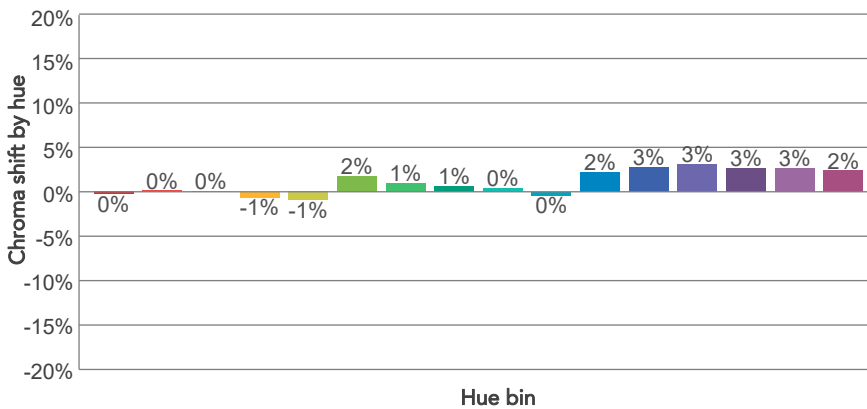
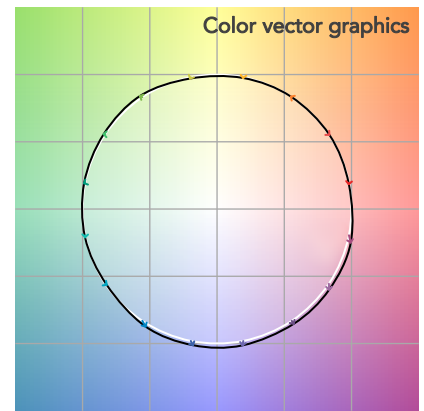
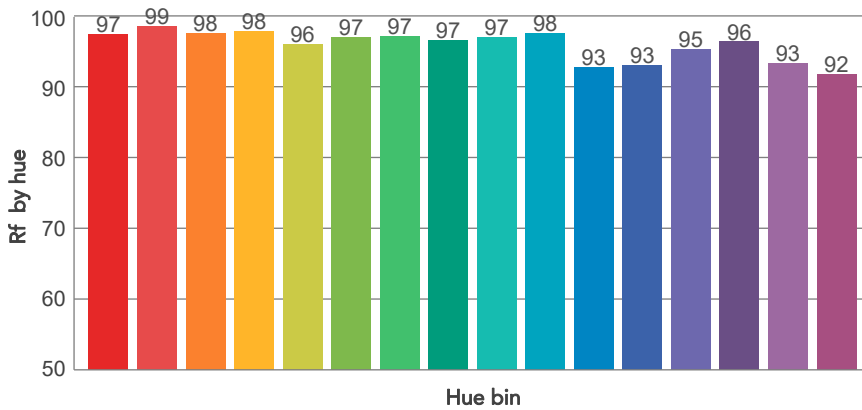
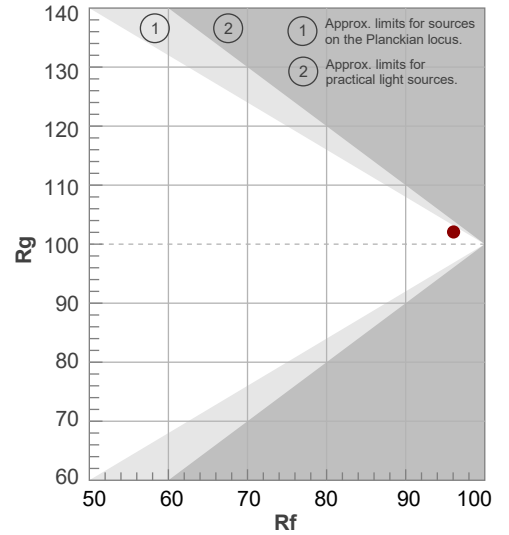

BEAM DETAILS



Beam angle 50%	Field angle 10%	Cut off angle 2,5%	Intensity ratio in 120° cone	Intensity ratio in 90° cone
65,4°	71,2°	72,7°	99,7%	99,7%

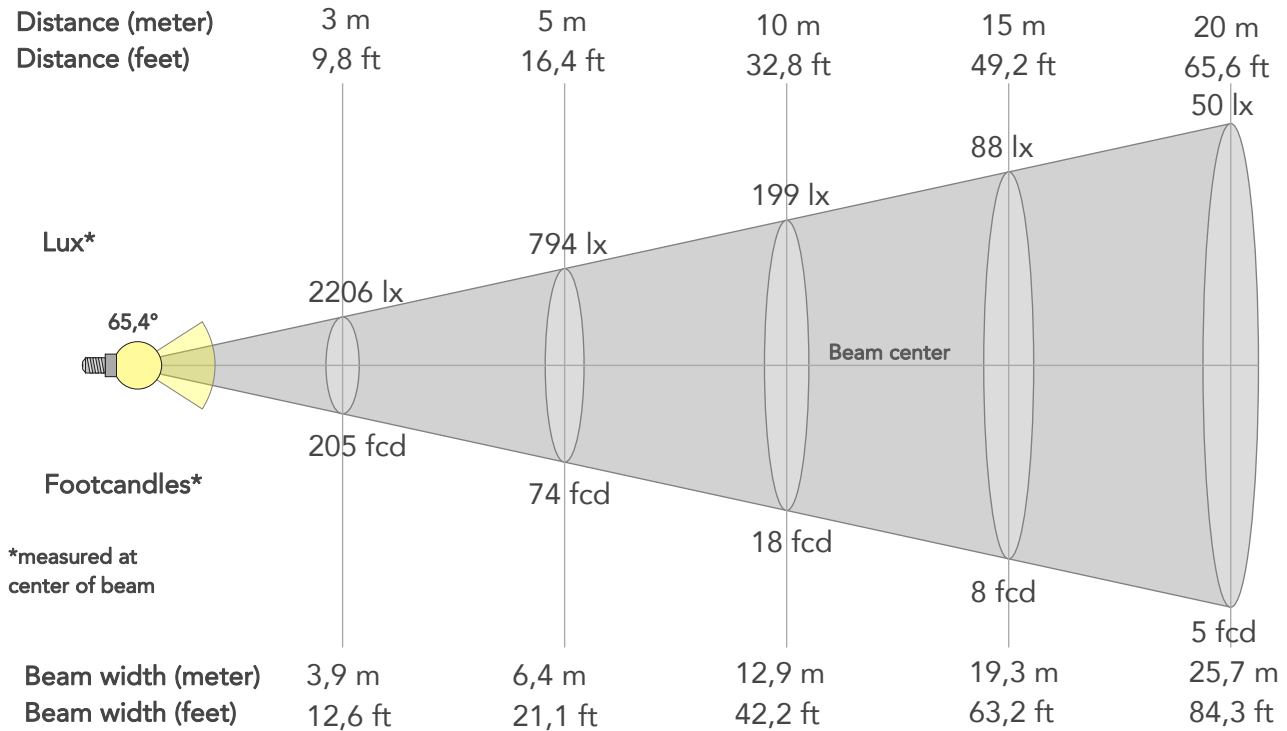

BEAM INTENSITIES AND WIDTHS

Distance	1m	2m	3m	4m	5m	7,5m	10m	15m	20m	25m	30m	40m	50m
Distance	3,3ft	6,6ft	9,8ft	13,1ft	16,4ft	24,6ft	32,8ft	49,2ft	65,6ft	82ft	98,4ft	131,2ft	164ft
Lux	19856lx	4964lx	2206lx	1241lx	794lx	353lx	199lx	88lx	50lx	32lx	22lx	12lx	8lx
Footcand.	1845fcd	461fcd	205fcd	115fcd	74fcd	33fcd	18fcd	8fcd	5fcd	3fcd	2fcd	1fcd	1fcd
Beam wid.	1,3m	2,6m	3,9m	5,1m	6,4m	9,6m	12,9m	19,3m	25,7m	32,1m	38,6m	51,4m	64,3m
Beam wid.	4,2ft	8,5ft	12,6ft	16,8ft	21,1ft	31,6ft	42,2ft	63,2ft	84,3ft	105,4ft	126,5ft	168,6ft	210,8ft

LINEAR DISTRIBUTION DIAGRAM

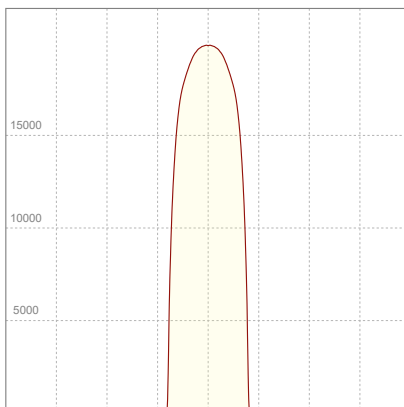

ELECTRICAL SPECIFICATIONS

Input voltage	Input current	Input power	Power FC	Efficiency
226V	1,96A	431,4W	0,97	42lm/W

ISO DIAGRAMS

ISO CANDELA DIAGRAM

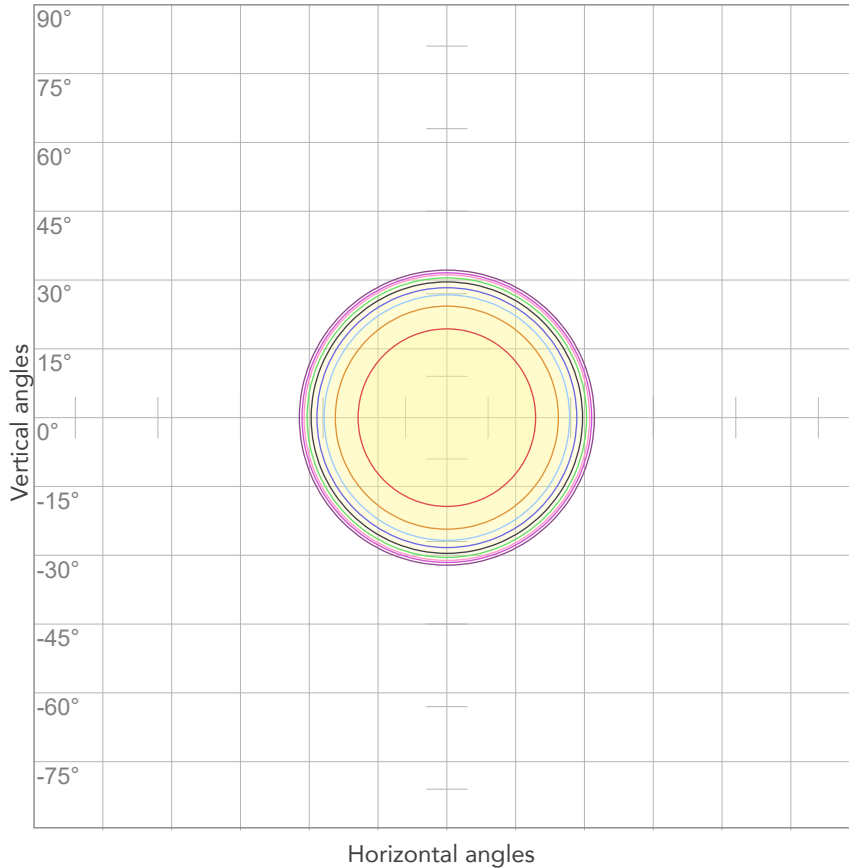

10%	1986 cd
20%	3971 cd
30%	5957 cd
40%	7942 cd
50%	9928 cd
60%	11914 cd
70%	13899 cd
80%	15885 cd

Conditions:

Number of c-planes: 2

Candela at center: 19856 cd

ISO LUX DIAGRAM

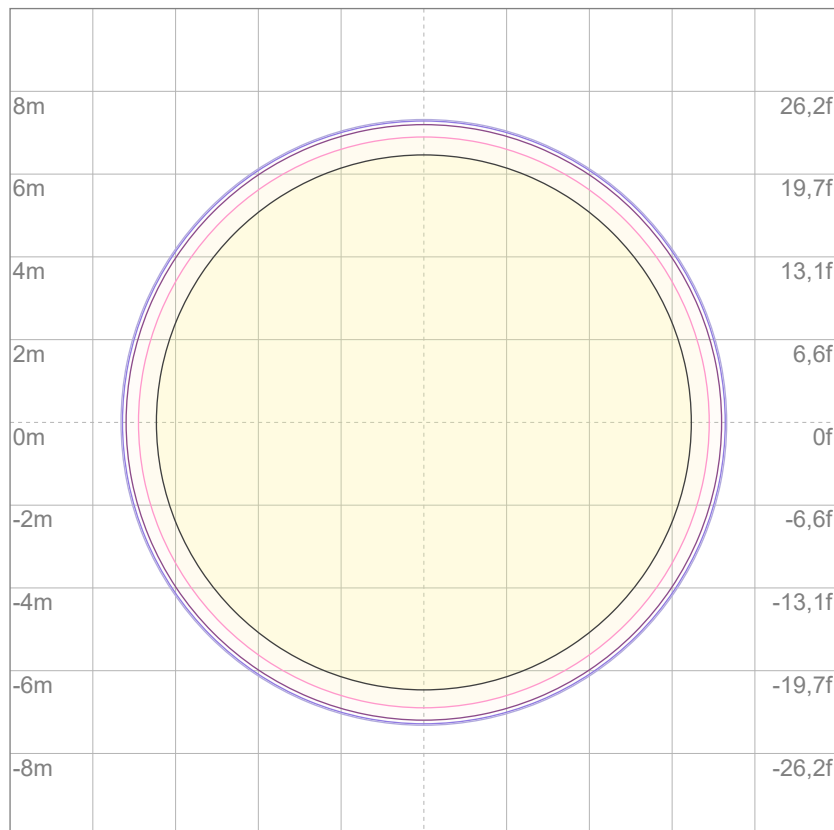

3%	5,96 lx
5%	9,93 lx
10%	19,9 lx
30%	59,6 lx
50%	99,3 lx

Conditions:

Number of c-planes: 2

Lux at center: 199 lx

Lux distribution on a surface when lamp is mounted at 10 meters from the surface.

Mounting height: 10 meters (33 feet)



Total lumen output:

19614 lm

Peak candela output:

21733 cd

Light quality:

CRI: 96,2

Color temperature:

5607 K

PRODUCT NAME:

ECLFWHPVW

MEASUREMENT CONDITIONS:

Beam angle:

PRL70

Target:

5600K

Operator:

Giuseppe della Peruta

Date and time:

08/01/2026 17:48:53

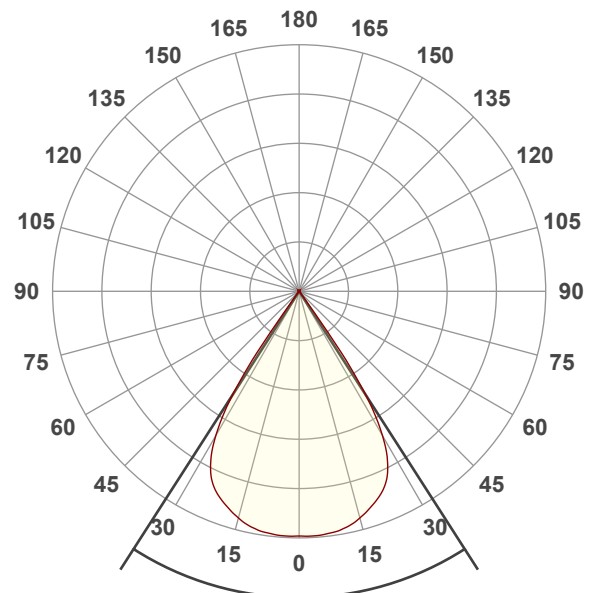

Beam angle 50%: 65,4°

Field angle 10%: 71,2°

Cut off angle 2.5%: 72,6°

Spectra

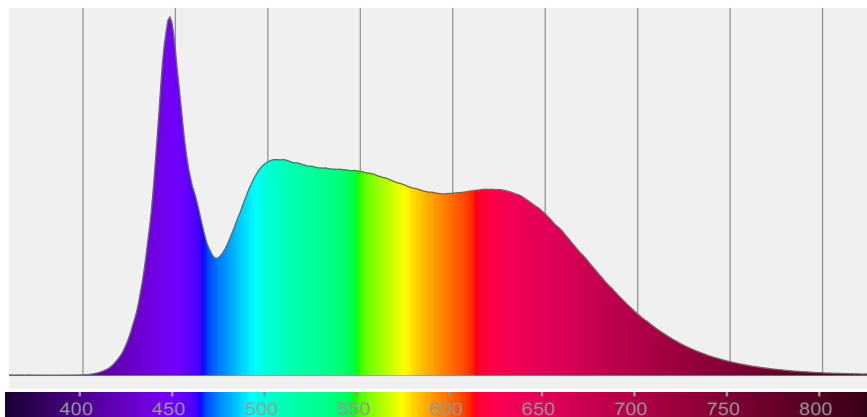

COLOR DETAILS

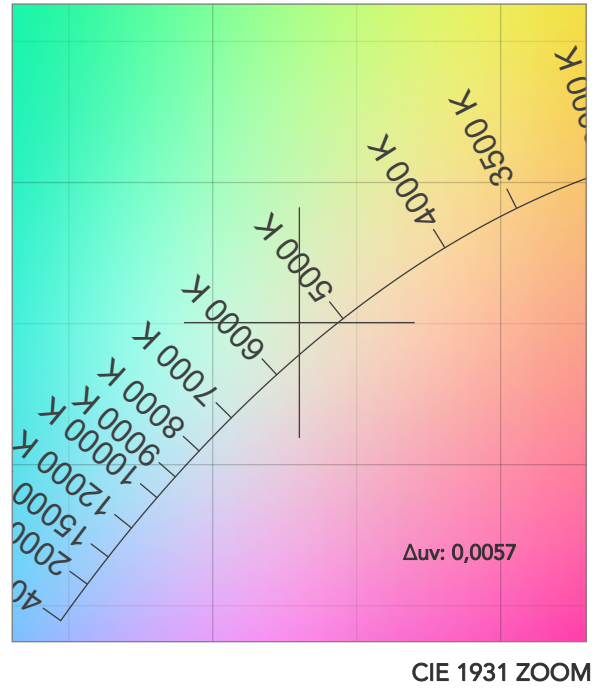
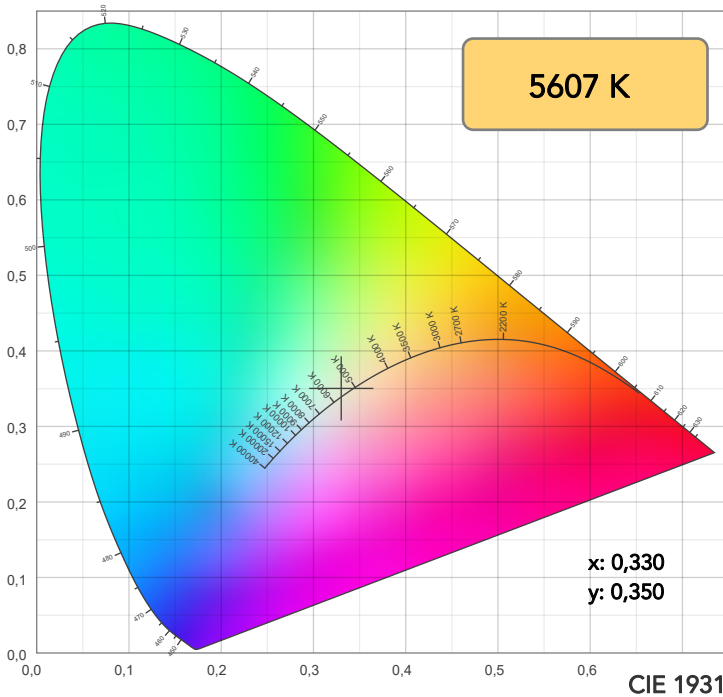

TM30: 95,3

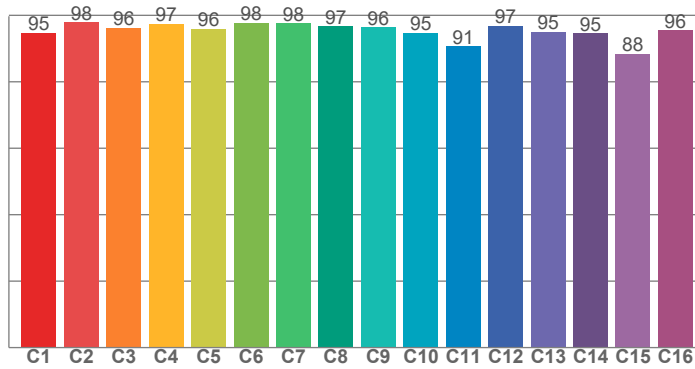

CRI: 96,2 (R1-R8)

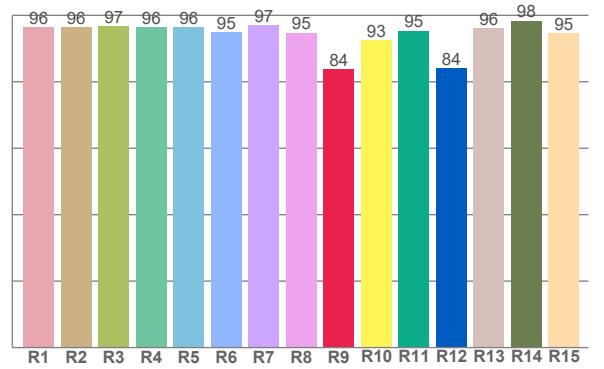

CRI R values, only R1-R8 are used to calculate final CRI value

R1	R2	R3	R4	R5	R6	R7	R8	R9	R10	R11	R12	R13	R14	R15
96,4	96,3	96,7	96,5	96,4	95,0	97,2	94,8	83,7	92,6	95,4	84,1	96,2	98,4	94,6

TM30 C values, 16 binned values out of total of 99 C values

C1	C2	C3	C4	C5	C6	C7	C8	C9	C10	C11	C12	C13	C14	C15	C16
94,8	97,9	96,3	97,4	95,9	97,8	97,6	96,7	96,4	94,8	90,7	96,9	95,1	94,7	88,4	95,6

CQS Q values

Q1	Q2	Q3	Q4	Q5	Q6	Q7	Q8	Q9	Q10	Q11	Q12	Q13	Q14	Q15
96,6	99,4	93,0	95,4	97,5	96,2	97,2	99,0	99,7	98,1	98,6	98,3	98,3	95,6	96,0

CQS: 96,8

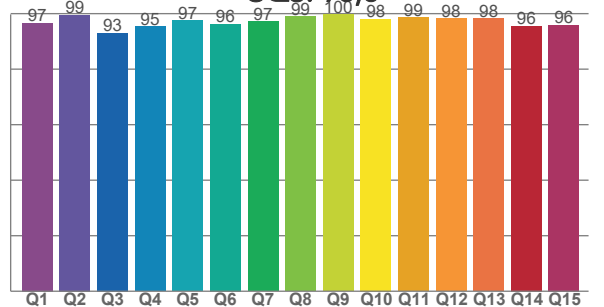

COLOR PARAMETERS

Color temperature	Color rendering index	Red component	Color fidelity	Color gamut	Color quality scale	Television lighting index	Color coordinate cie 1931	Color coordinate cie 1931	Color deviation from black body
CCT	CRI	CRI R9	TM30 Rf	TM30 Rg	CQS	TLCI	x	y	Δuv
5607 K	96,2	83,7	95,3	100,7	96,8	99	0,330	0,350	0,0057

TM30 DETAILS

Rf 95,3
Fidelity index Rf

Rg 100,7
Gammut index

Hue Bin	R _f	Graphic shifts (%)	
		Chroma	Hue
1	95	-2%	-1%
2	98	-1%	0%
3	96	-1%	1%
4	97	-1%	0%
5	96	-1%	0%
6	98	1%	1%
7	98	0%	0%
8	97	-1%	0%
9	96	-1%	2%
10	95	-1%	3%
11	91	2%	6%
12	97	2%	1%
13	95	4%	-2%
14	95	2%	-2%
15	88	6%	-9%
16	96	0%	-2%

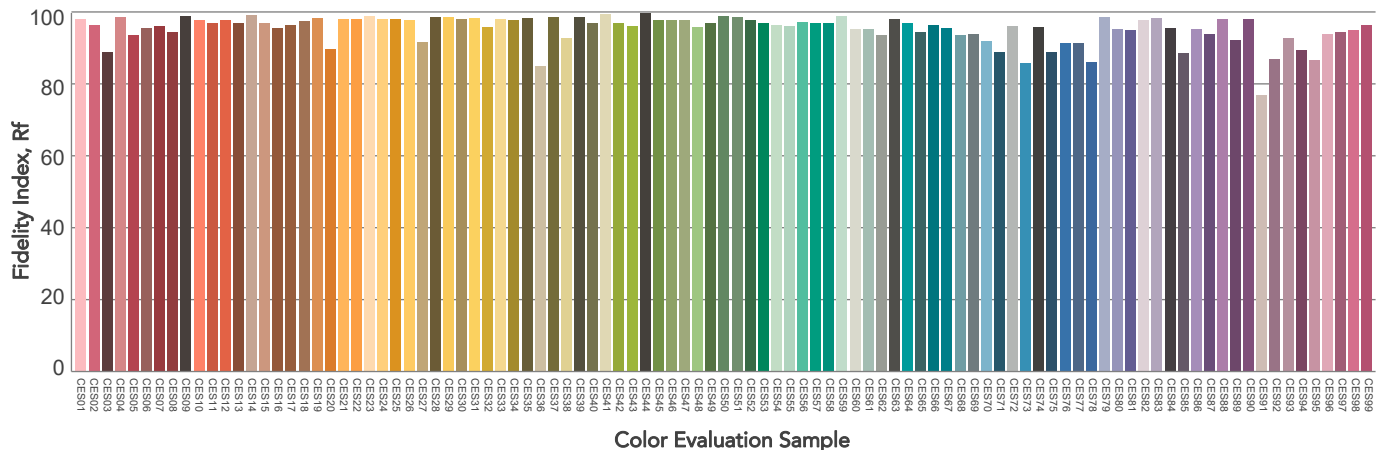
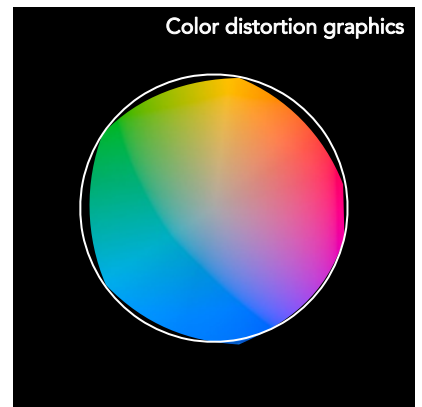
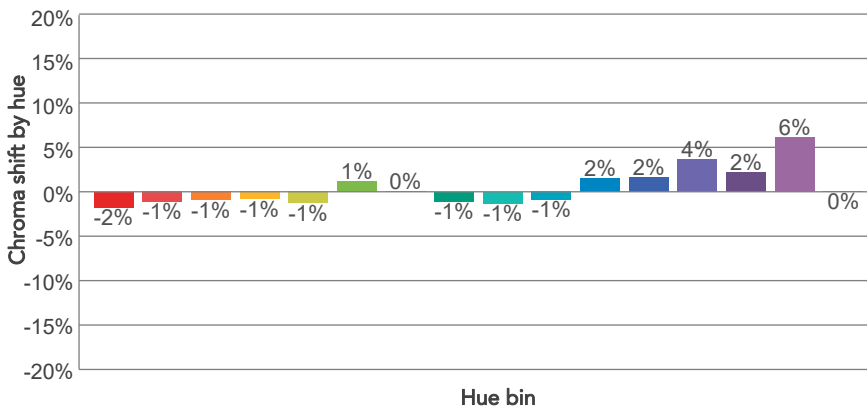
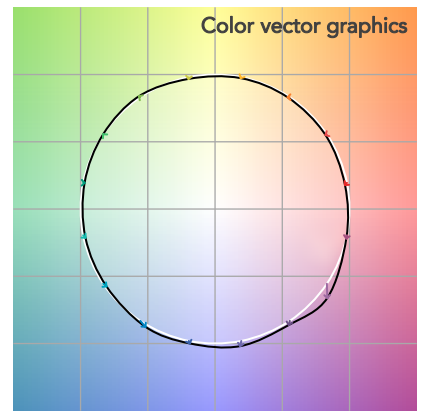
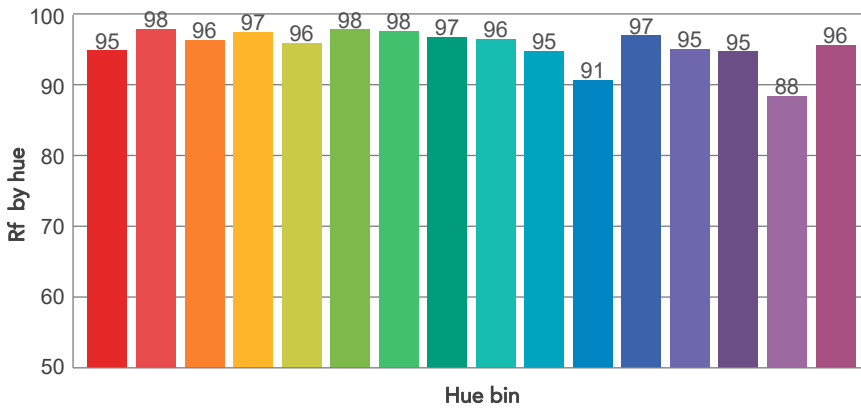
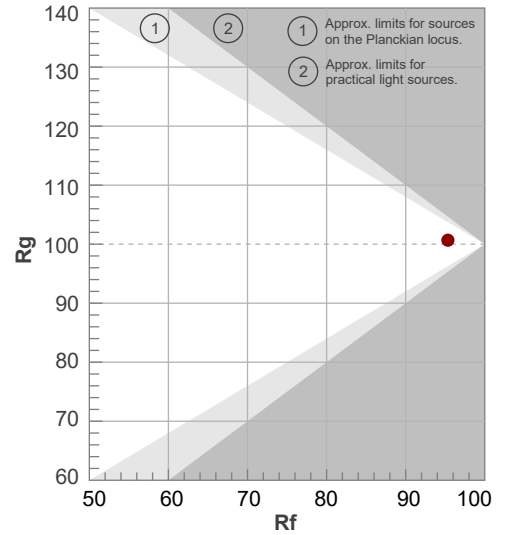

BEAM DETAILS



Beam angle 50%	Field angle 10%	Cut off angle 2,5%	Intensity ratio in 120° cone	Intensity ratio in 90° cone
65,4°	71,2°	72,6°	99,7%	99,6%

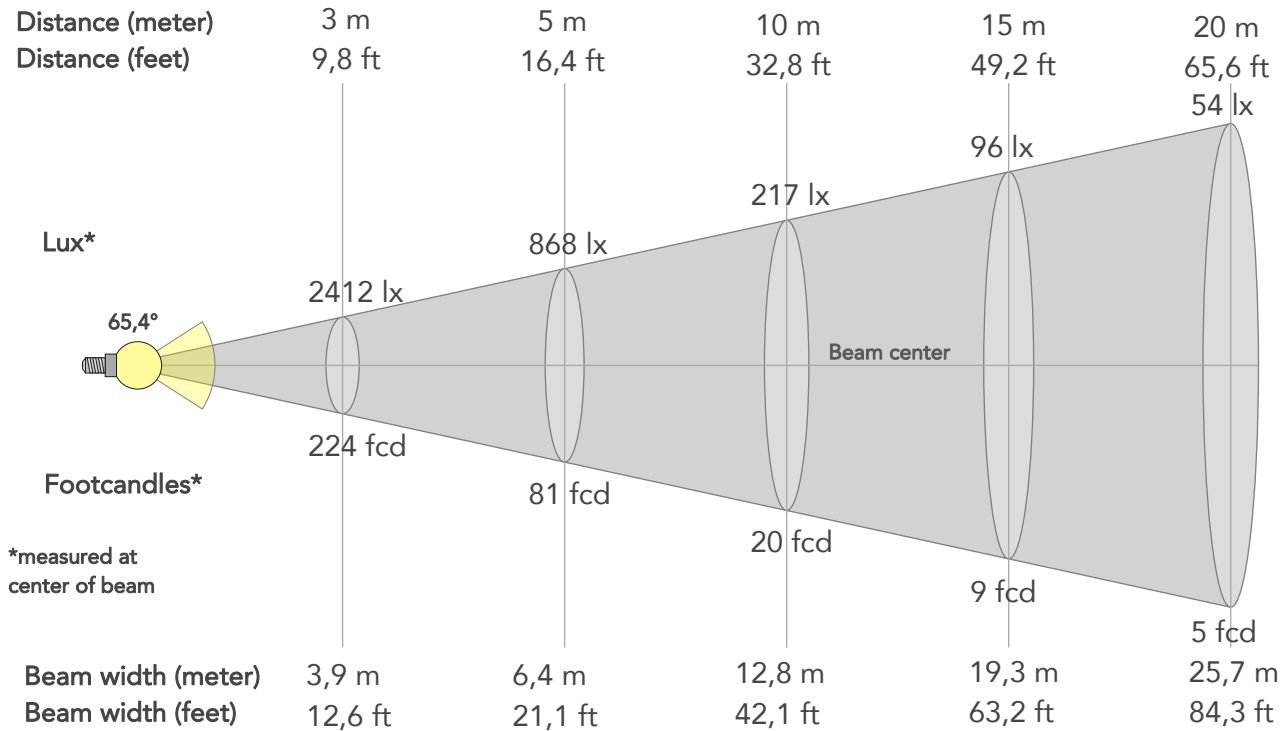

BEAM INTENSITIES AND WIDTHS

Distance	1m	2m	3m	4m	5m	7,5m	10m	15m	20m	25m	30m	40m	50m
Distance	3,3ft	6,6ft	9,8ft	13,1ft	16,4ft	24,6ft	32,8ft	49,2ft	65,6ft	82ft	98,4ft	131,2ft	164ft
Lux	21706lx	5427lx	2412lx	1357lx	868lx	386lx	217lx	96lx	54lx	35lx	24lx	14lx	9lx
Footcand.	2017fcd	504fcd	224fcd	126fcd	81fcd	36fcd	20fcd	9fcd	5fcd	3fcd	2fcd	1fcd	1fcd
Beam wid.	1,3m	2,6m	3,9m	5,1m	6,4m	9,6m	12,8m	19,3m	25,7m	32,1m	38,5m	51,4m	64,2m
Beam wid.	4,2ft	8,5ft	12,6ft	16,8ft	21,1ft	31,6ft	42,1ft	63,2ft	84,3ft	105,3ft	126,4ft	168,6ft	210,7ft

LINEAR DISTRIBUTION DIAGRAM

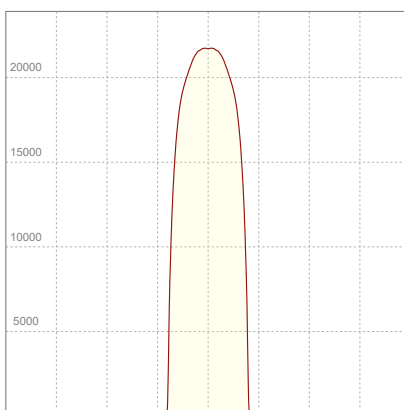

ELECTRICAL SPECIFICATIONS

Input voltage	Input current	Input power	Power FC	Efficiency
226V	1,98A	435,9W	0,97	45lm/W

ISO DIAGRAMS

ISO CANDELA DIAGRAM

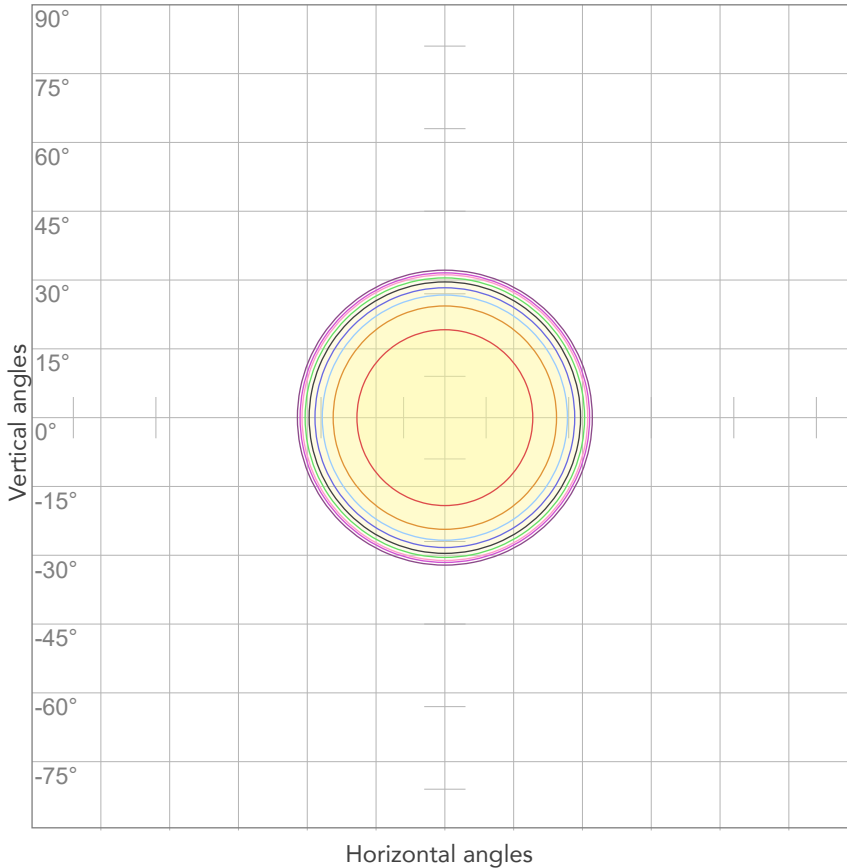

10%	2171 cd
20%	4341 cd
30%	6512 cd
40%	8682 cd
50%	10853 cd
60%	13024 cd
70%	15194 cd
80%	17365 cd

Conditions:

Number of c-planes: 2

Candela at center: 21706 cd

ISO LUX DIAGRAM

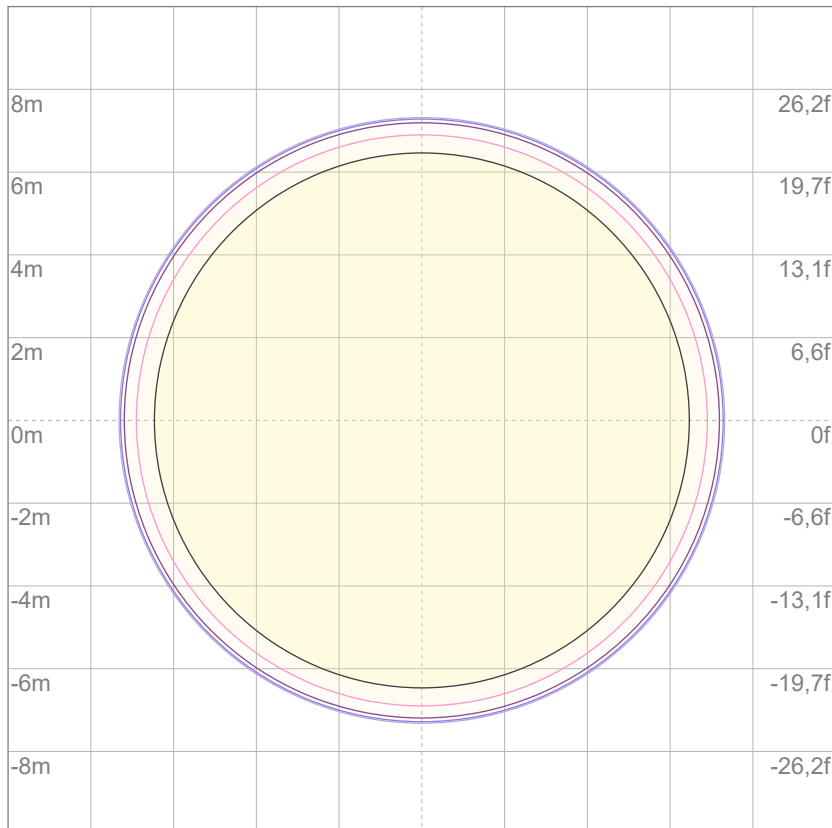

3%	6,51 lx
5%	10,9 lx
10%	21,7 lx
30%	65,1 lx
50%	109 lx

Conditions:

Number of c-planes: 2

Lux at center: 217 lx

Lux distribution on a surface when lamp is mounted at 10 meters from the surface.

Mounting height: 10 meters (33 feet)



Total lumen output:

19031 lm

Peak candela output:

21084 cd

Light quality:

CRI: 95,8

Color temperature:

6032 K

PRODUCT NAME:

ECLFWHPVW

MEASURAMENT CONDITIONS:

Beam angle:

PRL70

Target:

6000K

Operator:

Giuseppe della Peruta

Date and time:

08/01/2026 17:53:59

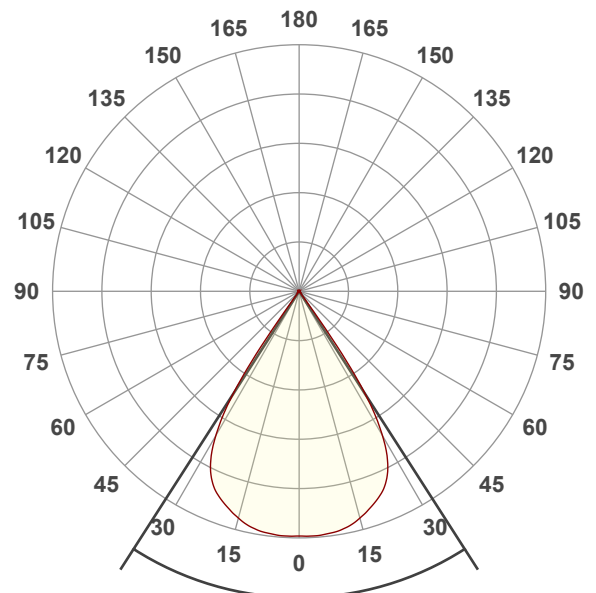

Beam angle 50%: 65,4°

Field angle 10%: 71,4°

Cut off angle 2.5%: 72,8°

Spectra

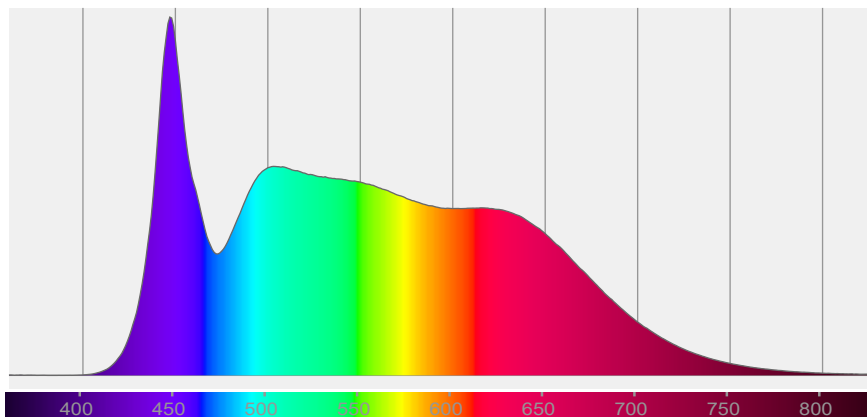

COLOR DETAILS

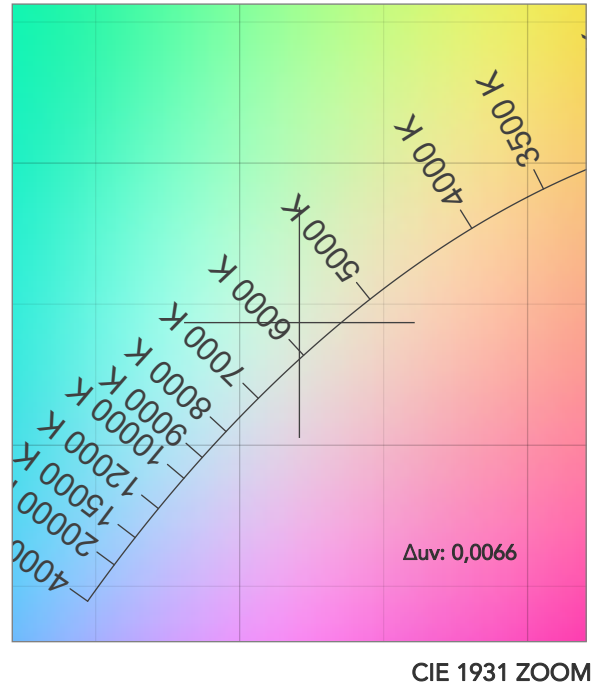
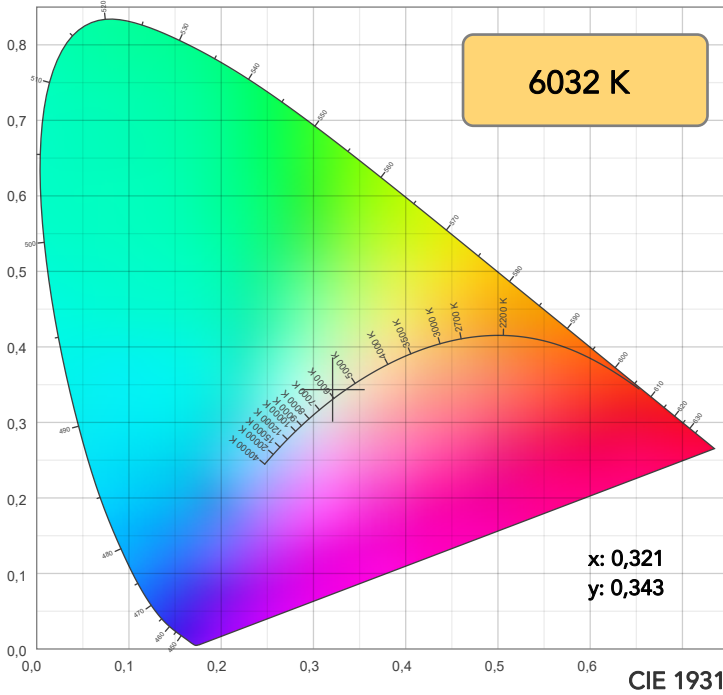

TM30: 94,9

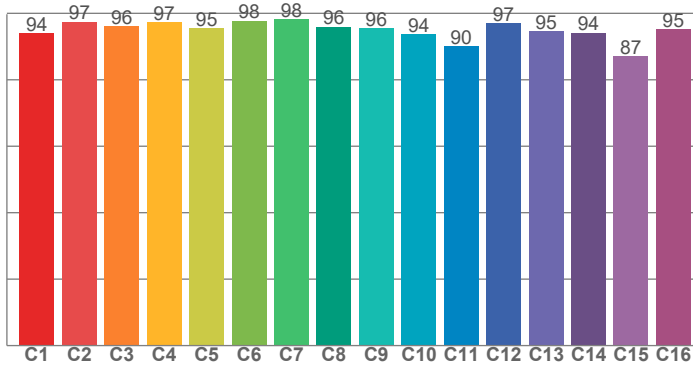

CRI: 95,8 (R1-R8)

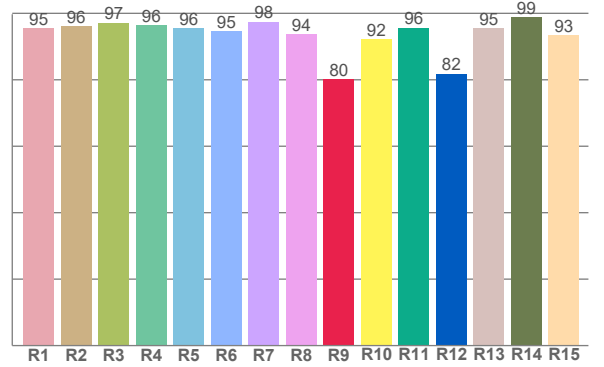

CRI R values, only R1-R8 are used to calculate final CRI value

R1	R2	R3	R4	R5	R6	R7	R8	R9	R10	R11	R12	R13	R14	R15
95,5	96,1	97,2	96,5	95,6	94,6	97,5	93,7	80,2	92,1	95,7	81,9	95,4	98,8	93,4

TM30 C values, 16 binned values out of total of 99 C values

C1	C2	C3	C4	C5	C6	C7	C8	C9	C10	C11	C12	C13	C14	C15	C16
93,9	97,4	96,1	97,3	95,4	97,8	98,1	96,0	95,6	93,7	90,0	97,0	94,5	94,1	87,1	95,3

CQS Q values

Q1	Q2	Q3	Q4	Q5	Q6	Q7	Q8	Q9	Q10	Q11	Q12	Q13	Q14	Q15
95,6	99,6	92,9	94,6	97,3	96,8	97,1	98,6	99,5	98,4	98,5	98,1	97,9	94,7	95,2

CQS: 96,4

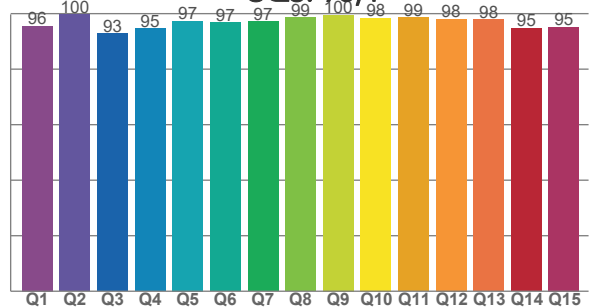

COLOR PARAMETERS

Color temperature	Color rendering index	Red component	Color fidelity	Color gamut	Color quality scale	Television lighting index	Color coordinate cie 1931	Color coordinate cie 1931	Color deviation from black body
CCT	CRI	CRI R9	TM30 Rf	TM30 Rg	CQS	TLCI	x	y	Δuv
6032 K	95,8	80,2	94,9	100,0	96,4	99	0,321	0,343	0,0066

TM30 DETAILS

Rf 94,9
Fidelity index Rf

Rg 100,0
Gammut index

Hue Bin	R _f	Graphic shifts (%)	
		Chroma	Hue
1	94	-2%	-1%
2	97	-1%	0%
3	96	-1%	1%
4	97	-1%	0%
5	95	-2%	0%
6	98	0%	0%
7	98	0%	0%
8	96	-2%	0%
9	96	-2%	3%
10	94	-1%	4%
11	90	2%	6%
12	97	2%	1%
13	95	4%	-2%
14	94	2%	-3%
15	87	6%	-10%
16	95	-1%	-2%

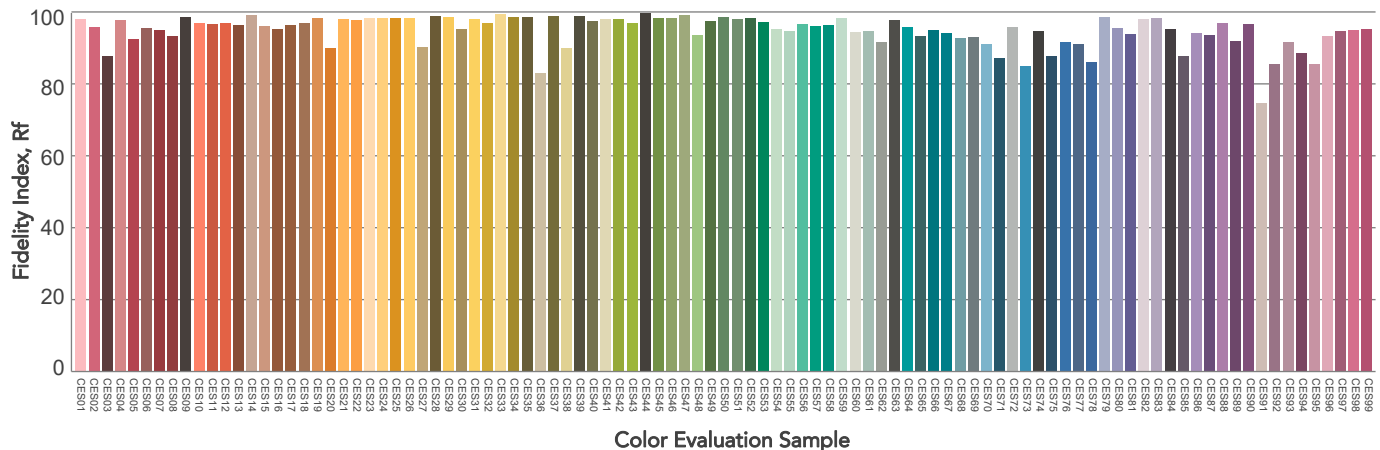
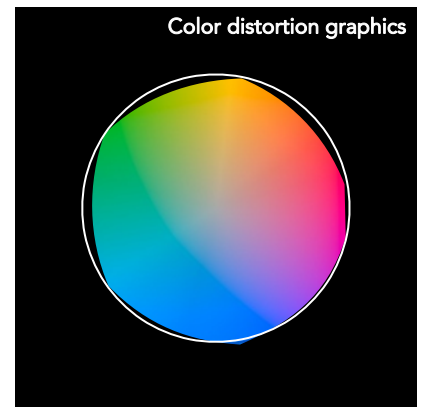
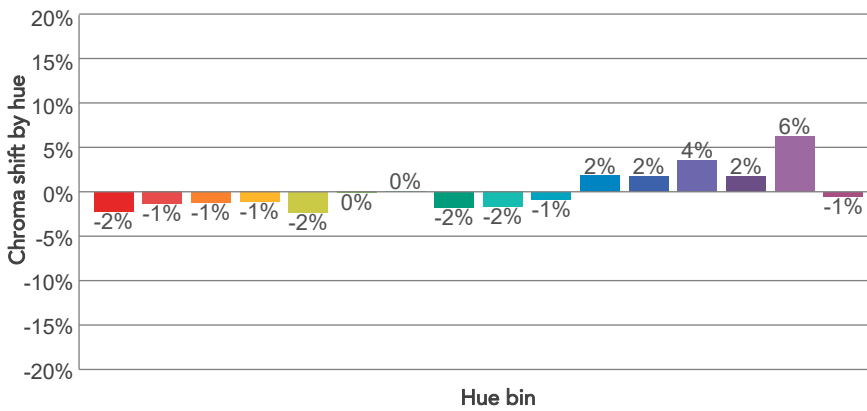
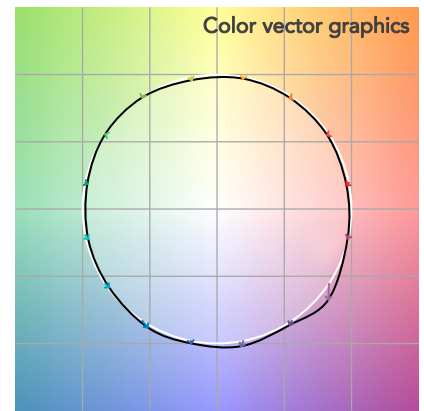
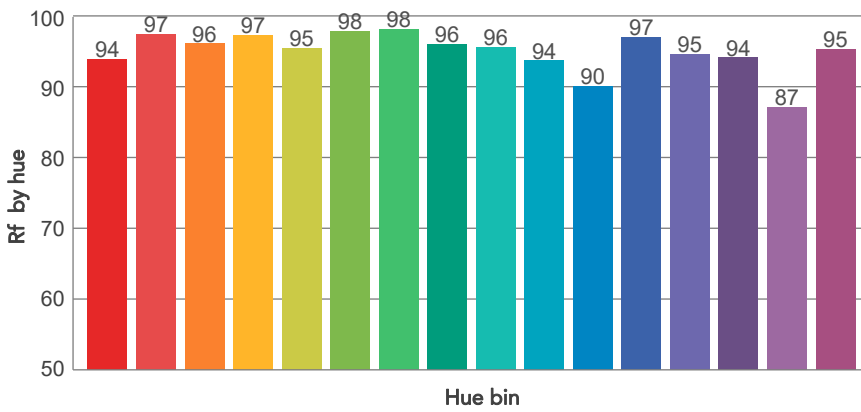
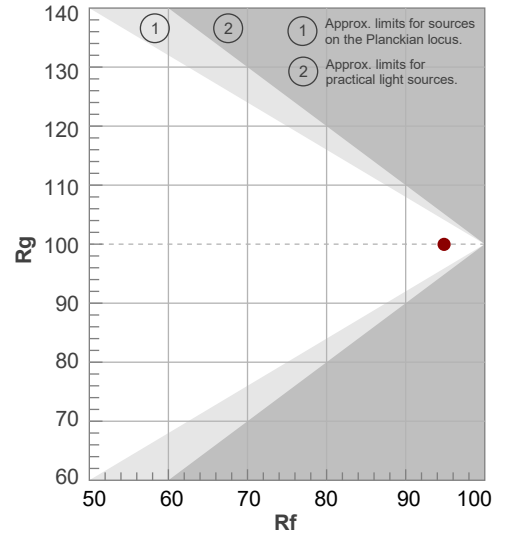

BEAM DETAILS



Beam angle 50%	Field angle 10%	Cut off angle 2,5%	Intensity ratio in 120° cone	Intensity ratio in 90° cone
65,4°	71,4°	72,8°	99,7%	99,7%

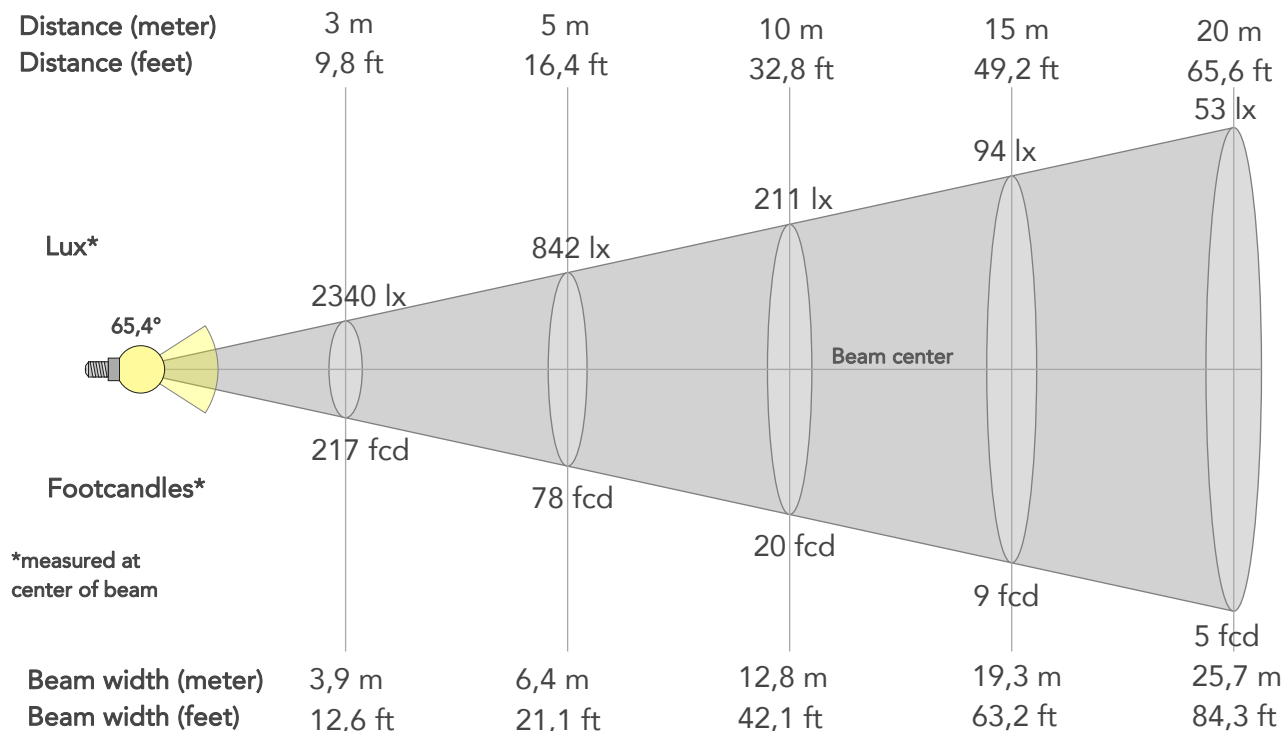

BEAM INTENSITIES AND WIDTHS

Distance	1m	2m	3m	4m	5m	7,5m	10m	15m	20m	25m	30m	40m	50m
Distance	3,3ft	6,6ft	9,8ft	13,1ft	16,4ft	24,6ft	32,8ft	49,2ft	65,6ft	82ft	98,4ft	131,2ft	164ft
Lux	21059lx	5265lx	2340lx	1316lx	842lx	374lx	211lx	94lx	53lx	34lx	23lx	13lx	8lx
Footcand.	1956fcd	489fcd	217fcd	122fcd	78fcd	35fcd	20fcd	9fcd	5fcd	3fcd	2fcd	1fcd	1fcd
Beam wid.	1,3m	2,6m	3,9m	5,1m	6,4m	9,6m	12,8m	19,3m	25,7m	32,1m	38,5m	51,4m	64,2m
Beam wid.	4,2ft	8,5ft	12,6ft	16,8ft	21,1ft	31,6ft	42,1ft	63,2ft	84,3ft	105,3ft	126,4ft	168,6ft	210,7ft

LINEAR DISTRIBUTION DIAGRAM

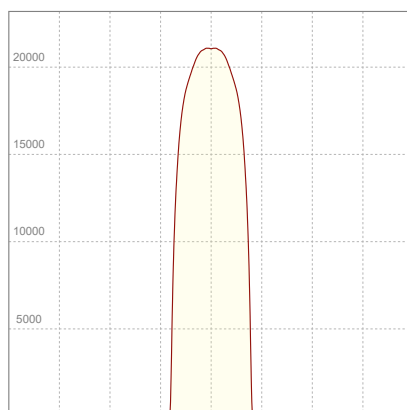

ELECTRICAL SPECIFICATIONS

Input voltage	Input current	Input power	Power FC	Efficiency
227V	1,90A	418,8W	0,97	45lm/W

ISO DIAGRAMS

ISO CANDELA DIAGRAM

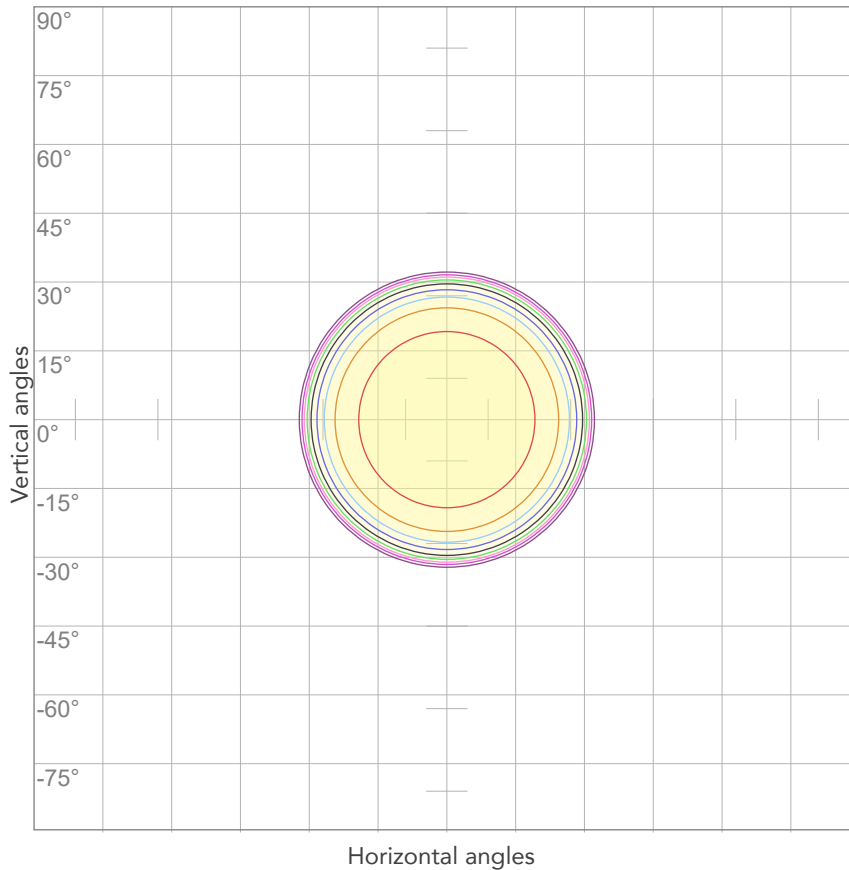

10%	2106 cd
20%	4212 cd
30%	6318 cd
40%	8424 cd
50%	10530 cd
60%	12636 cd
70%	14741 cd
80%	16847 cd

Conditions:

Number of c-planes: 2

Candela at center: 21059 cd

ISO LUX DIAGRAM

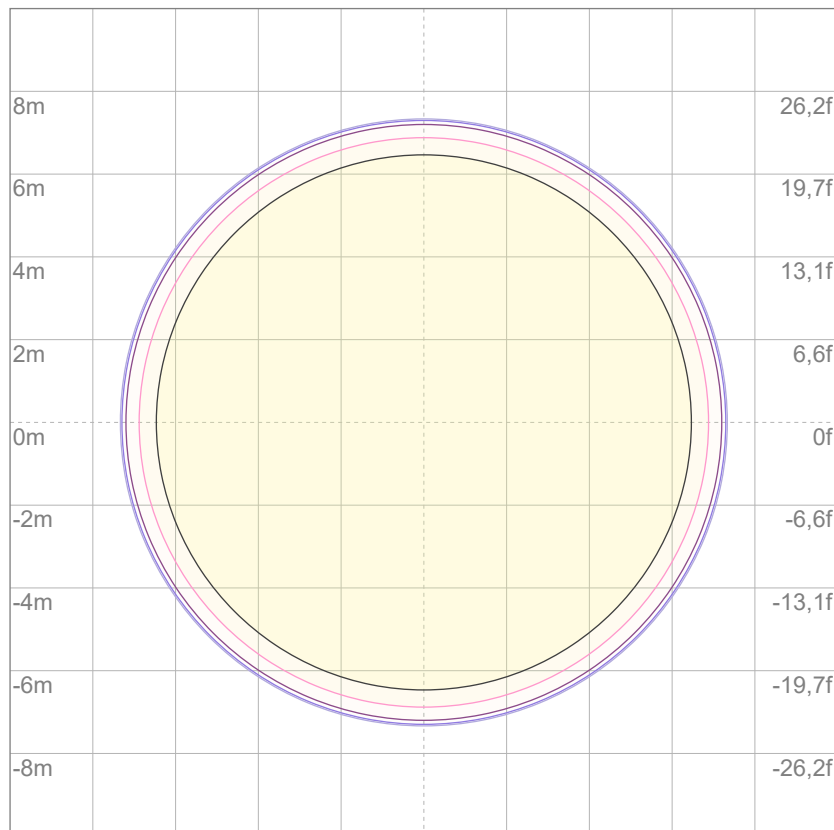

3%	6,32 lx
5%	10,5 lx
10%	21,1 lx
30%	63,2 lx
50%	105 lx

Conditions:

Number of c-planes: 2

Lux at center: 211 lx

Lux distribution on a surface when lamp is mounted at 10 meters from the surface.

Mounting height: 10 meters (33 feet)