

MODEL: AROLLA PROFILE HP

CODE: CL3014

June 25, 2025

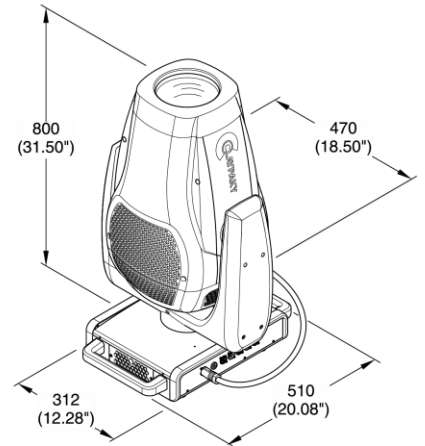
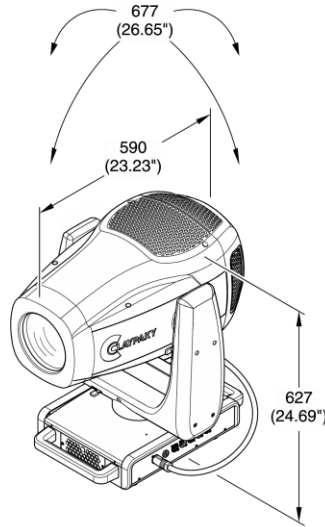

LIGHT SOURCE:

- Source type:** • White LED
 - Power:** • 1200 W
 - Color temperature:** • 6000 K
 - CRI:** • 70+ with selectable filter for CRI 88+
 - LED life expectancy:** • 40.000 Hrs L70*
- * It may vary depending on various factors, such as the type of use and environment

PHOTOMETRIC DATA:

- Zoom range:** • 5.8° - 50.5°
- Lm output:** • 52.000 Lm (integrating sphere)
- Front lens:** • Ø 160 mm
- Optical syt.:** • High efficiency

NOISE LEVEL:

- Fixed presets:**
 - Auto mode – 1200 W: 47.3 dB
 - Auto mode – 800 W: 44.1 dB
 - Const. mode – 1200W: 48.0 dB
 - Const. mode – 800W: 45.1 dB
 - Const. mode – 600W: 44.2 dB
 - Hold mode – 600W: 43.2 dB
 - Silent mode: 41.3 dB
 - Theatre mode: 40.3 dB

CONTROL & CONNECTIONS:

- Personalities:** • 2 modes with 39 / 41 control channels
- Protocols:** • DMX, Art-Net, sACN, RDM
- Connectors:** • Locking 5 pin XLR IN/OUT
• RJ45 IN
- Power con.:** • PowerCon True1 IN/OUT
- Web server:** • Built-in
- CloudIO:** • Fully compatible

DYNAMIC EFFECTS:

- Colors:**
 - Linear CMY
 - Linear CTO
 - Fixed color wheel with 6 dichroic colors including high CRI filter
- Framing Systems:**
 - 4 blades with ±60° rotation of the full system
 - “Total curtain” effect allowing the full blackout with each single blade
 - Built-in macros
- Gobos:**
 - 1 rotating gobo wheel with 6 HD indexable and replaceable gobos
 - 1 static gobo wheel with 7 HD replaceable gobos
 - Ext. diam. 31.9 mm
 - Image diam. 24 mm
 - Thickness 1.1 mm

- Frost:**
- Light frost 1° for soft diffusion
 - Heavy frost 5° for wash effect
- Rotating effects:**
- Aluminum animation wheel with continuous rotation in both directions at variable speed
 - Four-faced prism with rotation in both directions at variable speed
- Iris:**
- Motorized with variable pulse and random effects
- Movement:**
- Tilt: 540° - 16 bit
 - Pan: 270° - 16 bit
 - Automatic repositioning
 - Fast / Medium / Slow speed selectable by functional channel
 - Mechanical Pan/Tilt lock for safe transportation and maintenance
- Beam:**
- Motorized zoom and focus
- Dimmer / Shutter:**
- High resolution electronic dimmer - 24 bit, 5 curves
 - High speed electronic shutter and strobe

HARDWARE & SOFTWARE:

- Long life self-charging battery
- Display graphic LCD backlit B/W display
- Firmware upload from another fixture
- Firmware upgrade via Web Server
- Diagnostic
- DMX monitoring
- Remote access through RDM

HOUSING:

- Aluminium and steel structure with plastic covers
- Two side handles for transportation
- IP20 protection rate
- Working in any position
- Hanging system: with fast-lock Omega clamps (1/4 turn) on the base
- Optional safety chain

ELECTRICAL:

- Operating voltage:**
- 100-240V, 50/60 Hz
- Power Supply:**
- Electronic auto range with active PFC
- MAX power consumption:**
- 1650 VA

THERMAL SPECIFICATION:

- MAX Ambient temperature:**
- 45°C (113°F)
- Min Ambient Temperature:**
- -20°C (-4°F)
- MAX temp. of the ext. surface:**
- 90°C (194°F)
- Total heat dissipation:**
- 5636 BTU/hr ±10% / 5940 kJ/hr ±10%

SAFETY SPECIFICATIONS:

- Min. dist. of illum. objs:**
- 2.5 m (8'2")
- Min. dist. from flamm. mat.:**
- 0.2 m (8")
- Protections:**
- Fuse T25A – 250V
 - Thermally protected power supply (overheating and cooling failure)
 - Forced ventilation with axial fans

COMPLIANCE:

CE Marking (in conformity to the following):

- 2014/35/EU - Safety of electrical equipment supplied at low voltage (LVD)
- 2014/30/EU - Electromagnetic Compatibility (EMC)
- 2011/65/EU - Restriction of the use of certain hazardous substances (RoHS)
- 2009/125/EC - EcoDesign requirements for Energy-related Products (ErP)

UKCA conforms to UK regulations:

- S.I. 2016 N. 1101
- S.I. 2016 N. 1091
- S.I. 2012 N. 3032
- S.I. 2010 N. 2617

cMETus LISTED:

- UL 1573:2003
- CSA C22.2 N.166:2015

PACKAGING:

- Carton box + Polystyrene
- Carton box + Foam shell
- Flight case + Foam shell (1 positions)

WEIGHT & SIZES:

- Weight:**
- 44.7 Kg (98.5 lbs)
- Base dim.s:**
- 312 x 510 mm
 - 12.28 x 20.08 In
- Height with vert. head (h):**
- 800 mm
 - 31.5 In
- Dist. b/t 2 fixt:**
- 660 mm

ACCESSORIES:

- Omega bracket:**
- 183102/805 (Included)
- ETL Power:**
- CAB02B/802 (Optional)*
- * Cord 1.5 m (bare end with IP65 PowerConTrue1 conn.)
- Foam shell:**
- F21311/001 (Optional)
- Flight case (1 pos):**
- CF1013F (Optional)
- Safety Chain:**
- 105041/003 (Optional)